



EDLC & LiC CAPACITORS

2026/2027



ENGINEERED SOLUTIONS

JIANGHAI EUROPE
Electronic Components GmbH

Capacitors from Jianghai

JIANGHAI EUROPE ELECTRONIC COMPONENTS GMBH IS THE EUROPEAN SALES ORGANIZATION OF NANTONG JIANGHAI CAPACITOR CO., LTD., NANTONG (CHINA). SINCE 2003, SALES, MARKETING, TECHNICAL SUPPORT, CUSTOMER SERVICE TEAM AND WAREHOUSE OF JIANGHAI EUROPE ELECTRONIC COMPONENTS GMBH ARE LOCATED IN KREFELD AND KEMPEN (GERMANY).

» ELECTROLYTIC CAPACITORS

Jianghai has grown since its foundation in 1958 to become the largest Chinese manufacturer of aluminum capacitors generating revenues of 1,35 billion USD in 2025. While Jianghai started in the beginning with the production of specialty chemicals (e.g., electrolyte solutions), it entered the production of aluminum electrolytic capacitors already in 1970.



» INTEGRATION OF PREMATERIAL

More recently, Jianghai extended its production range by integrating high and low voltage anode foil etching and forming facilities. All factories are located in mainland China and Japan: the most important ones are in Nantong (north to Shanghai), in Inner Mongolia, and in Xi'An area. Jianghai is well prepared for further expansion due to its successful entrance to the stock market in summer 2010.

» FILM CAPACITORS

In 2012, the product portfolio was complemented by a range of power film capacitors. For this new business unit, Jianghai also follows the strategy of vertical integration and thus the production comprises the metallization and slitting of the plastic film as well as the assembly of the finished goods. Highly automated production facilities ensure the efficient mass production of film capacitor modules. Driven by the thriving electric vehicle market in China, Jianghai has attained a leading position for the supply of these customer specific components.



» POLYMER CAPACITORS

The year 2013 was marked by a major breakthrough in R&D for polymer aluminum electrolytic capacitors: the voltage proof for these ultra-low ESR products was pushed out to as much as 200V, enabling the utilization of these advanced capacitors in more applications, e.g. in white goods, industrial automation, telecom infrastructure, power supplies, and LED ballasts. Hybrid and Stacked (Chip) Polymer Capacitors were added into the product portfolio in the year 2019.



» ENERGY CAPACITORS

For energy storage applications, Jianghai has developed a range of Lithium Ion-Capacitors (Li-C) based on the well-known EDLC technology. Li-C combine the advantage of many hundred thousand charge and discharge cycles and high energy density, allowing for a wide range of applications in energy storage and recuperation. Jianghai offers EDLC as well as Li-C in various form factors, e.g. in radial, snap-in, pouch or module shape.



» CAPACITOR COMPETENCE CENTER

Global presence of experienced sales and technical marketing experts at offices in Europe, Asia and the Americas ensure the local support of our customers based on sound know-how in all project phases. In 2014 Jianghai Europe has established an additional service for its customers in Europe: Experts for capacitors are awaiting telephone calls or emails at the CCcenter as a kind of hotline for all kind of technical requests.

» CUSTOMIZED PRODUCTS

Jianghai's particular strength as a volume manufacturer is to offer customized products. Jianghai focuses on the demanding professional industrial segment with many power electronics applications. Research and development in collaboration with several specialized university institutes as well as the access to all vital pre-materials enable Jianghai to create engineered, customized solutions to fit smoothly into a specific application. Jianghai is continuously improving processes, thereby enhancing the quality of its products and services. The list of certificates awarded to Jianghai reflects its level of achievement. In the year 2013, the Jianghai Europe sales office has become certified according to ISO9001 and ISO14001.

» CONTACT

Jianghai Europe Electronic Components GmbH
 Uerdinger Str. 95 · 47799 Krefeld, Germany
 T: +49 (21 51) 65 20 88-0 | F: +49 (21 51) 65 20 88-88
 info@jianghai-europe.com | www.jianghai-europe.com

OVERVIEW ENERGY CAPACITORS (ENERGY-C)

Handling Precautions	6
Energy-C: Introduction EDLC & LiC	9
Energy-C: Comparison & Advantages	10
Energy-C: Typical Applications	11
Overview EDLC & LiC	12
Chapter EDLC	15
Chapter LiC	45
Overview Modules (EDLC & LiC)	60

EDLC 15

RADIAL SINGLE CELL TYPE

EDLC: Order Code RADIAL SINGLE CELL	16
EDLC: Technical Specifications RADIAL SINGLE CELL	17

SERIES	CODE	TYPE	TEMPERATURE RANGE	VOLTAGE	INFO	
SC SRP	PR	RADIAL SINGLE CELL	-40 ~ +70°C	2,7V	Standard	18
SC SRE	ER	RADIAL SINGLE CELL	-40 ~ +65°C	3V	Enlarged Voltage Range	20
SC SRQ	QR	RADIAL SINGLE CELL	-40 ~ +85°C	2,7V	Higher Temperature Range	22

RADIAL MULTI CELL TYPE

EDLC: Order Code RADIAL MULTI CELL	24
EDLC: Technical Specifications RADIAL MULTI CELL	25

SERIES	CODE	TYPE	TEMPERATURE RANGE	VOLTAGE	INFO	
SC SRM	MR	RADIAL MULTI CELL	-40 ~ +70°C	5,5V	Standard	28
SC SRS	SR	RADIAL MULTI CELL	-40 ~ +65°C	6V	Higher Voltage	30
SC SRO	OR	RADIAL MULTI CELL	-40 ~ +85°C	5,5V	Higher Temperature Range	32

SNAP-IN TYPE

EDLC: Order Code SNAP-IN	34
EDLC: Technical Specifications SNAP-IN	35

SERIES	CODE	TYPE	TEMPERATURE RANGE	VOLTAGE	INFO	
SC SSP	PS	SNAP-IN	-40 ~ +65°C	2,7V	Standard	36
SC SSE	ES	SNAP-IN	-40 ~ +65°C	3V	Higher Voltage	37
SC SSL	LS	SNAP-IN	-40 ~ +65°C	2,7V	Higher Capacitance	38

WELDED COLUMN TYPE

SERIES	CODE	TYPE	TEMPERATURE RANGE	VOLTAGE	INFO	
SC SSL-J	LS	WELDED COLUMN	-40 ~ +60°C	3V	High Current	39

AXIAL TYPE

EDLC: Order Code AXIAL	40
EDLC: Technical Specifications AXIAL	40

SERIES	CODE	TYPE	TEMPERATURE RANGE	VOLTAGE	INFO	
SC SGP	PG	AXIAL	-40 ~ +65°C	2,7V	Standard	41
SC SGE	EG	AXIAL	-40 ~ +65°C	3V	Higher Voltage	43

LITHIUM-ION-CAPACITORS 45
RADIAL TYPE

LiC: Order Code RADIAL	46
LiC: Technical Specifications RADIAL	46

SERIES	CODE	TYPE	TEMPERATURE RANGE	CYCLES	INFO	
SC HBR	BR	RADIAL	-15 ~ +70°C	up to 500 000	Standard	47
SC HBRL	BL	RADIAL	-25 ~ +70°C	up to 250 000	Wider Temperature Range	49
SC HBE	BE	RADIAL	-25 ~ +70°C	up to 250 000	Highest Capacitance	51

AXIAL/WELDED COLUMN TYPE

SERIES	CODE	TYPE	TEMPERATURE RANGE	CYCLES	INFO	
SC HGA	GA	AXIAL	-25 ~ +65°C	50 000	High Power Density	53

POUCH TYPE

LiC: Order Code POUCH	55
LiC: Technical Specifications POUCH	55

SERIES	CODE	TYPE	TEMPERATURE RANGE	CYCLES	INFO	
SC HAA	AA	POUCH	-25 ~ +55°C	50 000	Standard	56
SC HAE	AE	POUCH	-25 ~ +55°C	50 000	Highest Capacitance	58

MODULES (EDLC & LiC) 60

Modules always customer specific and on request.

WARNING

JIANGHAI is not liable for any extent of possible injuries or damages to persons or things, of any kind, caused by the improper application of and/or operating conditions harmful to Energy-Capacitors. Misapplications which may cause failures include, but are not limited to: operating current or peak current or voltage outside the specified range, operating voltage above surge voltage specified, temperature exposure outside of the specified operating temperature range. Examples of harmful operating conditions comprise, but are not limited to: unusual storage or transport temperatures, excessive and/or rapid changes of ambient temperature or humidity, heavy mechanical shock or vibration, corrosive and abrasive particles in the ambient (cooling) air, conducting dust in the ambient (cooling) air, oil or water vapor or corrosive substances, explosive gas or dust, operation under extremely high or low ambient pressure conditions (below or above sea level), superimposed radio frequency voltages, radioactivity. In case of doubt about the impact of operating conditions on capacitor performance, please contact JIANGHAI. Personal safety Electrical or mechanical misapplication of Energy-Capacitors may be hazardous. Personal injury or property damage may result from explosion of a capacitor or from the expulsion of electrolyte due to mechanical disruption or the release of a safety vent of a capacitor. In case of injury or skin or eye exposure to electrolyte, immediately seek professional medical advice. Before using Energy-Capacitors in any application, please read these Handling Precautions, familiarizing thoroughly with the information contained herein. Please check before using any of our Energy-Capacitors if these components fulfill the requirements of your application and that warnings and instructions for use are followed.

WARRANTY

The information contained in this datasheet does neither form part of any quotation nor of a contract, it is believed to be accurate, reliable and up to date. Quality data are based on the statistical evaluations of a large quantity of parts and do not constitute a guarantee in a legal sense. However, agreement on these specifications does mean that the customer may claim for replacement of individual defective capacitors within the terms of delivery. We cannot assume any liability beyond the replacement of defective components. This applies in particular to any further consequences of component failure. Furthermore it must be taken into consideration that the figures stated for lifetime, failure rates and outlier percentages refer to the average production status and are therefore to be understood as mean values (statistical expectations) for a large number of delivery lots of identical capacitors. These figures are based on application experience and data obtained from preceding tests under normal conditions, or – for purpose of accelerated aging – more severe conditions. JIANGHAI reserves the right to change these specifications without prior notice. Any application information given is advisory and does not form part of any specification. The products are not primarily designed for use in life supporting applications, devices or systems where malfunction of these products can reasonably be expected to result in personal injury. JIANGHAI customers using or selling these products for use in such applications without prior written consent of JIANGHAI do so at their own risk and agree fully to indemnify JIANGHAI for any damage resulting from such improper use or sale. This version of the datasheet supersedes all previous versions.

HANDLING GUIDELINES

- (1) Energy-Capacitors must not be used in AC and filtering circuits.
- (2) The actual operating voltage must not exceed the max. specified operating voltage and it must not fall below the min. specified operating voltage.
- (3) Please check the polarity before using. If operated under reverse polarity conditions, the capacitors will not only suffer from a shortened life time, but they may even swell, and electrolyte leakage or other malfunctions may result.
- (4) Environment: The operating temperature has an influence on the life time of the capacitors, and the maximum specified operating temperature must never be exceeded.
- (5) Current drain during discharge needs to be controlled to avoid a voltage drop below the min. voltage of the capacitor. The permissible current drain I_R is usually specified in the datasheet.
- (6) Capacitors in series connection: when capacitors are connected in series connection it must be ensured that the operating voltage of any single capacitor does not exceed to the limit of the max. and min. operating voltages. Systems for balancing and monitoring as well as modules are available on request. Please contact the JIANGHAI EUROPE Sales office for further information.
- (7) Energy-Capacitors must not be short-circuited. Discharge below the minimum voltage will destroy the capacitor.

PRECAUTIONS

- (1) Prohibition of disassembly

Any attempt to disassemble the capacitor may result in short circuits to the capacitor, which may generate gas, and may cause electrolyte leakage, explosion or other problems.

- (2) Prohibition of dumping capacitors into fire to avoid potential risk of explosion.
- (3) Prohibition of immersing capacitors into water or seawater or any similar liquid.
- (4) Prohibition of using damaged capacitors: If any abnormal features of the capacitors are found (especially such as damages of the package, electrolyte leakage or others) the capacitor cannot be used anymore and must be stored away from open flames.
- (5) Prohibition of short-circuit or use outside the specified operating voltage range.
- (6) Prohibition of reverse voltage.

PRECAUTIONS FOR DEVICES USING ENERGY-CAPACITORS

The operating conditions for modules, devices or application using Energy-Capacitors must follow the detailed operating condition of the individual cell.

OPERATING VOLTAGE (U_R)

Energy-Capacitors are specified with a maximum operating voltage $U_{MAX} = U_R$ and a minimum operating voltage U_{min} . For a safe operation, these limits must be strictly adhered to.

OVERVOLTAGE

Overvoltage is not allowed.

EFFECT OF CURRENT FLOW

Energy-Capacitor used with large currents will generate heat. Do not apply currents exceeding the maximum charge/discharge current. It may generate heat, deform, explode or lose electrolyte. Comply with the

maximum specified charge/discharge currents in the datasheet.

RATED CURRENT (I_R)

The rated current is the current which is specified in the IEC 62391-1.

MAX. CONTINUOUS CURRENT (I_{MAX})

The maximum continuous current is the current which can be used to charge and discharge the capacitor repeatedly without any pause. The current generates a temperature increase and must be considered with existing outside temperature. The maximum temperature must not be exceeded.

SURGE CURRENT (I_S)

The surge current is the maximum charge/discharge current and it is limited (see datasheet). The maximum temperature must not be exceeded.

SELF-DISCHARGE CURRENT (I_{SD})

The self-discharge current is specified after 3 months at ambient temperature of 25°C, relative humidity between 25% to 85% and without further voltage applied with t in seconds.

$$I_{SD} = \frac{C \cdot (U_R - U_3)}{t}$$

SELF-DISCHARGE VOLTAGE (U_{SD})

The self-discharge voltage is specified at ambient temperature 25±2°C. The following procedure must be followed to determine the self-discharge voltage drop:

- the capacitor is charged to rated voltage with constant current (operational current, see datasheet)
- the capacitor is kept at the rated voltage for 30 minutes
- open the circuit and store the capacitor for 72 hours at an ambient temperature of 25±2°C
- measure the self-discharge voltage between the capacitor terminals with a high ohmic voltmeter.

LEAKAGE CURRENT (I_{leak}) The leakage current is specified at ambient temperature 25±2°C. The following procedure must be followed to determine the leakage current:

- the capacitor is charged to rated voltage with constant current (operational current, see datasheet)
- the capacitor is kept at the rated voltage for 72 hours, during which the leakage current declines to a steady-state value
- measure the leakage current between the capacitor terminals for the characteristic leakage current

POLARITY

The terminals of the product have a (positive or negative) polarity mark. Please check the polarity before using. Never apply any reverse voltage.

LIFETIME There are many different lifetime definitions known without any true standard definition. Take special care when capacitors of different manufacturers or technologies are compared. In the case of lifetime tests, please consider the rated operating voltage and rated operating temperature. Do not exceed the rated operating current.

LOAD LIFE

Period of time, during which the technical parameters of all capacitors stay within the given limits. JIANGHAI does not allow for outliers.

HIGH TEMPERATURE STORAGE TIME

Period of time, during which the technical parameters of all capacitors stay within the given limits. JIANGHAI does not allow for outliers.

CYCLE LIFE

Number of charge and discharge cycles at ambient temperature 25°C during which the technical parameters of all capacitors stay within the given current limits and voltage range. JIANGHAI defines this without allowing for outliers.

TEMPERATURE CHARACTERISTICS

The parameters of the capacitor are dependent of the temperature. Please check the datasheet or ask for assistance to define the temperature dependencies.

AC INTERNAL RESISTANCE (ESR_{AC})

Please note that the capacitor must not be connected to alternating voltage during regular operation. The only exemption is the determination of the ESR_{AC} , by a test procedure devised to determine the ESR without charging the component. At ambient temperature 25±2°C the capacitor is discharged to U_{min} with constant current I_R before testing. A sinusoidal alternating current signal with an amplitude of maximum 5 mA and a frequency of 1kHz is applied, then the decreasing alternating voltage at the capacitor is detected. The AC internal resistance of the capacitor is calculated according to the following formula:

$$ESR_{AC} = \frac{V_{AC}}{I_{AC}}$$

DC INTERNAL RESISTANCE (ESR_{DC})

At ambient temperature 25±2 °C, the DC internal resistance of a capacitor is evaluated by following these steps:

- the capacitor is charged to the rated voltage U_R with constant current I_R
- the capacitor is kept at the rated voltage U_R for 30 minutes
- the capacitor is discharged to the minimum operating voltage U_{min} with a constant current I_R , measure the voltage U_i after 30ms discharge
- repeat the steps for three times from (a) to (c)
- calculate the DC internal resistance of capacitor (ESR_{DC}) within the third cycle according to the following formula:

$$ESR_{DC} = \frac{(U_R - U_i)}{I}$$

VIBRATION AND MECHANICAL STRESS

Capacitors are sensitive to vibration and mechanical forces applied on the leads. Do not use capacitors, which have been dropped onto a rigid surface.

INSULATION

If any defect of the sleeve is visible, the component should not be used – the same holds for any kind of visible damage. A capacitor should be electrically isolated from the following parts: aluminum case, cathode lead wire, anode lead wire and circuit pattern, and auxiliary terminal of snap-in type. The sleeve of the capacitor is not an insulator and therefore the standard capacitor should not be used in a place where insulation function is needed. Please contact JIANGHAI if a higher grade of insulation is required.

ELECTROLYTE AND SEPARATOR PAPER

Electrolyte and separator paper used in Energy-Capacitors may be flammable. Also electrolyte is electrically conductive. Therefore in case electrolyte gets in contact with PC board it may cause corrosion of circuit pattern or cause short circuit between patterns, and may lead to smoke generation or ignition in worst case.

CAUTION DURING USE OF CAPACITORS

Do not touch the terminals of capacitors. Keep the capacitor free from conductive solution, such as acids, alkali and so on. Ensure that the operating environment of the equipment into which the capacitor has been built is within the specified conditions mentioned in the catalogue or specification sheets.

SAFETY VENT (RADIAL AND SNAP-IN)

The safety vent needs some free space to open properly. Allow free headroom of at least 2mm for diameter ≤ 16 mm, more than 3mm for diameter 18-35mm. Do not place any wires or PCB tracks above the valve.

SOLDERING

Please only use manual soldering. Don't use reflow soldering or wave-soldering or infrared heating or air heating. Heat shock will decrease the electric performance of capacitors or cause malfunction.

(1) Soldering temperature for radial and snap-in types should not exceed 260°C and soldering time not exceed 5s.

(2) Soldering temperature for pouch bag types should not exceed 420°C and soldering time not exceed 10s.

(3) One solder once (1 cycle).

Take measure at prevent Energy-Capacitors becoming short-circuited during the soldering process.

GLUEING, CLEANING AND COATING

Do not use fixing agents or cleaning substances containing halogens. Do not use coating and moulding components that completely seal the capacitors from the environment. Also never use solvents containing: Halogenated hydrocarbons, alkali, petroleum, trichloroethylene/-ethane, xylene, acetones, trichloro trifluoroethane, tetrachloroethylene, methylene chloride, chloroform, acetates, ketones, esters, chlorides and bromides.

MOUNTING

Other devices, which are mounted near the capacitor, should not touch the capacitor. Heat transferred from other components to the capacitor may reduce the lifetime of the capacitor. Do never bend or twist the capacitor after soldering to avoid stress on the leads. Radial capacitors are not protected against mechanical forces on the leads. Forces on the pins might damage the capacitor. No printed circuit board tracks are allowed between the lead pads of the capacitor.

TRANSPORTATION

(1) Do not apply excessive vibration or shock when transporting the product.

(2) Prevent the packaging from being dropped during transportation or being stabbed by fork, lift forks etc. during freight handling.

(3) Package the product with individual terminals isolated to prevent short-circuits between them.

(4) Do not allow the product to get wet from, for example, rainwater, seawater, ice and snow, dew condensation, or freezing during transportation.

(5) Package the product in materials strong enough to prevent damage from stacking.

(6) Avoid fumigation and spraying insecticides (especially with bromides) in the import or export procedures which can cause corrosion. This applies also to the finished devices.

STORAGE CONDITIONS FOR LITHIUM-ION-CAPACITORS

When storing the product for a long period of time, pack it in a way that stacking does not damage the product, taking care to preserve the isolation between individual terminals to prevent a short circuit between them.

(1) temperature 0°C to 35°C and relative humidity below 65%

(2) storage voltage 3,4V to 3,7V

(3) storage time above 1 year should be avoided

STORAGE CONDITIONS OF ELECTROLYTIC-DOUBLE-LAYER-CAPACITORS

When storing the product for a long period of time, pack it in a way that stacking does not damage the product, taking care to preserve the isolation between individual terminals to prevent a short circuit between them.

(1) temperature 15°C to 35°C and relative humidity below 65%

(2) uncharged state (Voltage:0~0,3V)

(3) storage time above 4 year should be avoided

MAINTENANCE

Periodical inspection should be carried out for the capacitor: visual inspection to check pressure relief open or leakage of electrolyte, electrical characteristic as self-discharge current and capacitance.

AIR TRANSPORTATION REGULATIONS

Currently, Energy-Capacitors are not considered as dangerous goods in 2015IATA Regulations (status as of January 1st, 2019). However, as air transportation regulations may change, it is recommended that you should check the regulations each time you are transporting Lithium-Ion Capacitors and use an appropriate transportation method.

IN CASE OF EMERGENCY

(1) If the capacitor becomes deformed or damaged, stop using it and replace it immediately.

(2) If the cell starts leaking electrolyte or released gas and smoke, stop using it and replace it immediately. Keep away from open flames or sources of ignition. Leaked electrolyte might cause short circuits on the PCB.

EMERGENCY ACTIONS

When the pressure relief vent is open and some gas blows out from the capacitor, please turn the main switch of the equipment off or pull out the plug from the power outlet immediately. During safety vent operation, extremely hot gas ($>100^\circ\text{C}$) may blow out of the capacitors. Do not stand close to the capacitors. In case of eye contact, rinse the open eye(s) with clean water immediately. In case of ingestion, gargle with water immediately, do not swallow. In the case of innervation please exposed to fresh air. Do not touch electrolyte but wash skin with soap and water in case of skin contact. In the case of an accident with electrolyte, please consult a doctor.

DISPOSAL

Following the rules of WEEE, Energy-Capacitors must be collected separately as electronic waste.

Jianghai Europe Electronic Components

2026v1

EDLC

The EDLC technology builds the basis of both types, which offers a relatively high energy density and a very high power density. The electrode material (activated carbon) is applied to an electrically contactable collector and forms the electrodes of the capacitors.

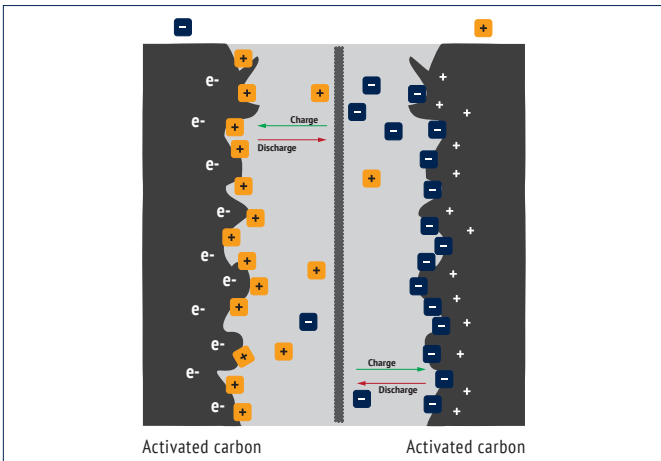

Fig. 1: Electrode structure of EDLC

A membrane („separator“), separates the electrodes from each other and thus protects them from short circuits. The separator must be permeable to the ions of the electrolyte. Those ions are the carriers of the electrical current in the EDLC (Fig. 1). If a voltage is applied, the positively and negatively charged ions migrate to the electrodes. The ions collect at the phase boundaries of the solid electrodes to the liquid electrolyte and form the so-

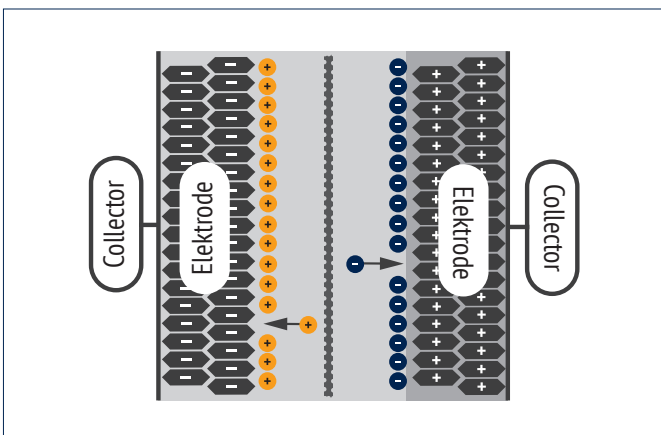

Fig. 2: Charged EDLC

called double layer. The resulting electric field polarizes solvent molecules between the layers that separate the charges. The two electrodes connected in series work like a series connection of two capacitors (Fig. 2). Due to the very small distances of the double layer and the large surface, the capacitance of an EDLC is very high.

LiC

The modified design of the Lithium-Ion-Capacitors (Li-C) allows significantly increased energy density. A lithium-doped graphite electrode replaces one of the two symmetrical electrodes. As a consequence power densities are a little reduced compared to

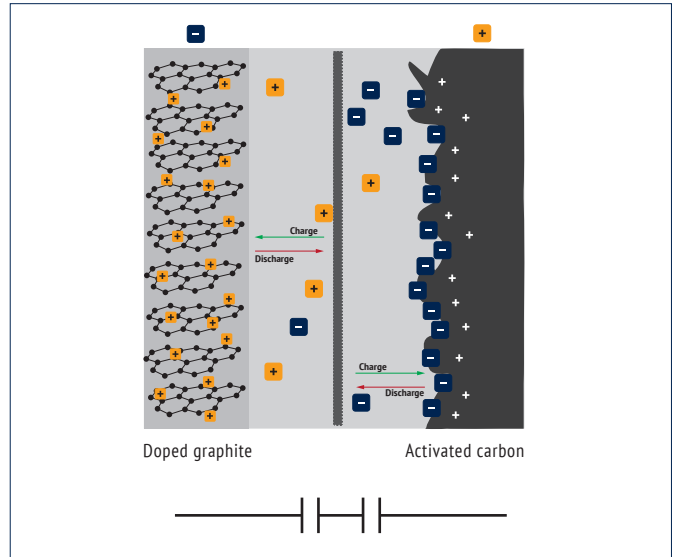

Fig. 3: Electrode structure of LiC

EDLC. Fig. (3) shows the inner construction of a Li-C: activated carbon like EDLC on one side and a doped graphite electrode on the other. As a result, Li-Cs approach the energy density close to batteries.

>> Energy storage is an integral part of our modern world and one of the challenges of the future. The technology called „Energy Capacitors“ provides the energy storage in capacitors with new boost. The Ragone diagram (Fig. 4) shows the power density of various electrical energy storage devices versus their energy density. The Energy-C concept basically uses two types of capacitors: the classic double-layer capacitor (EDLC) and the novel lithium-ion capacitor (LiC).

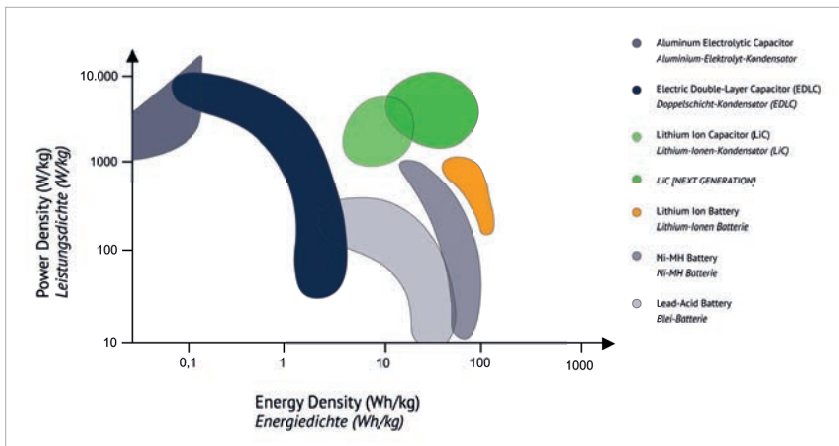

Fig. 4: Ragone diagram of various storage devices for electrical energy

In terms of cycle stability and lifetime, the Energy-Cs are far ahead of the batteries. While lithium ion batteries offer merely about a thousand cycles, LiCs reach several hundreds of thousands of cycles. The special design and material combination of the lithium-ion capacitor ensures stability and charge retention even at high temperatures.

While both batteries and Li-C remain stable at room temperature and discharge less than 5% over 2500 h, an EDLC already loses up to 30% of the charge after 2000h. At 60°C, the discharge rate increases significantly due to the accelerated chemical reactions

between electrolyte and electrode material. The consequence of these chemical reactions is an increased leakage current and this leads to charge loss in batteries and EDLCs alike.

While the leakage currents of the Li-C continue to be low, the lithium-ion battery now loses up to 30% of its charge after 2500 hours. When it comes to safety and reliability, the Li-C can also score: it is just as safe as an EDLC, due to the special process that firmly embeds the lithium ions in the molecular structure of the carbon structure („doping“).

Unlike lithium batteries, no elaborate designs are needed to reduce the risk of thermal runaway with the known fire hazard. Due to the doping, there are neither metallic lithium nor lithium oxide in the capacitor. The doping method thus allows the capacitor to be always in a safe condition even with mechanical damage, high temperature, or heavy discharge.

The production of a LiC requires less than 3% of the lithium amount of a lithium battery of the same volume. In addition to the aspect of efficiency of resources, this results in a lower weight / smaller design as a nice side effect. The Ragone diagram (Fig. 4) shows that lithium-ion capacitors open up a new range for applications that previously were not covered, neither by batteries nor by any other type of capacitor.

The Energy-C concept represents a new technology for existing and future applications of energy storage. The capacitors described here are already being mass produced by Jianghai and have proven their superior performance under real operating conditions in the field.

TECHNOLOGY COMPARISON: MAIN MATERIAL & PROPERTIES

	ENERGY-C (EDLC)	ENERGY-C (LiC)	LiB
ANODE	Activated carbon	Activated carbon	LiCoO ₂ / LiMnO ₄
CATHODE	Activated carbon	Graphite/Li-ion doped	Graphite/Li-ion doped
ELECTRIC STORAGE PRINCIPLE	Ion-adsorption	"Anode: Ion-adsorption Cathode: Ion-adsorption and charge transfer"	Reversible redox reaction
TEMPERATURE RANGE	-40 ~ 85 °C	-25 ~ 70 °C	-25 ~ 45 °C
MAX. RATED VOLTAGE	2.3 ~ 3 V	3.8 ~ 4.2 V	3.7 ~ 4.2 V
MAX. CHARGE RATE	approx. 1,000 C	approx. 100 C	0.5 ~ 1 C (normal)
SIZE/WEIGHT	low	low	high
CHARGE-/DISCHARGE-CYCLES	More than 500,000	50,000 ~ 500,000	1000
SELF DISCHARGE	>30 % after 2,000 h	<5 % after 2,500 h	<5 % after 2,500 h
SAFETY	safe	safe	depending on structure and material
ENERGY DENSITY	(5 ~ 8,5 Wh/kg)	(40 ~ 90 Wh/kg)	(~150-250 Wh/kg)



Traction and Railway, tram and electrified bus

Several functions could be realized by using Energy-C capacitors: reuse the power of braking, cost reductions by saving parts of the external electrification (overhead lines) and infrastructure. Fast charging during the stop and pick-up of passengers instead of a continuously connection to the grid are new concepts already in practice.



Elevators

Elevators often waste potential energy when the cabin goes down. Energy capacitors can be used to store the energy and use it for the next ascent. Such operation requires a high number of cycles combined with high charging- and discharging currents.



Automated Guided Vehicles

Automated Guided Vehicles automate and mobilize complete warehouses. Energy capacitors replacing batteries reduce the weight and volume significantly. The disadvantages of high maintenance costs and short service life of batteries is obsolete. Short stops during usage are used for charging the capacitors and allow a true 24-hour operation of all AGVs.



Recuperation of energy



Recuperation brakes in electric vehicles, in trains, in roller coasters or in machines like f.i. the fork of a forklift save energy and prolongs the life and usage time of the machine. There are thousands of applications with high numbers of charge-discharge cycles, which now can be used to increase the efficiency or allow a true energy saving. Additionally the life time of the batterie might be prolonged as the numbers of cycles for the battery are reduced.



Pitch Systems in Wind Turbines

Energy-Capacitors help to minimize costs due to their long service life and high cycle stability on this important safety unction.



Smartmeters & Energy Harvesting



Energy capacitors provide the energy for the short but intense transmission pulse. The Li-C, which has a much lower self-discharge than all other known technologies allow a true long-time handling even at high temperatures.



Backup systems

Energy-Cs allow extreme fast power in case of problems of the grid or power supplies, especially for larger power systems like hospitals, banks or industry. Such grid failures happen quite often in the range of milliseconds or seconds. The high number of cycles and the availability of large amounts of energy in a short time make energy capacitors the optimal technology choice.

RADIAL SINGLE

APPLICATIONS:

- 1 Smartmeter
- 2 Peakshaving Low Power
- 3 DC-Grid stabilisation
- 4 Energybuffer in Hybrid systems

SC SRP PR
2,7V
70°C

higher voltage →

SC SRE ER
3V
65°C

↓
higher
temperature

SC SRQ QR
2,7V
85°C

RADIAL MULTI

APPLICATIONS:

- 1 Smartmeter
- 2 Peakshaving Low Power
- 3 DC-Grid stabilisation
- 4 Energybuffer in Hybrid systems

SC SRM MR
5,5V
70°C

higher voltage →

SC SRS SR
6V
65°C

↓
higher
temperature

SC SRO OR
5,5V
85°C

SNAP-IN

APPLICATIONS:

- 1 Peakshaving mid Power
- 2 DC-Grid stabilisation
- 3 Recuperation
- 4 Pitch-Systems

SC SSP PS
2,7V
65°C

higher voltage →

SC SSE ES
3V
65°C

↓
higher
capacitance

SC SSL LS
2,7V
65°C

WELDED COLUMN

APPLICATIONS:

- 1 High Current
- 2 Smart Powergrid
- 3 e-mobility

SC SSL-J LS
3V
60°C

AXIAL

APPLICATIONS:

- 1 Peakshaving high Power
- 2 High Power Grid Applications
- 3 High Power UPS
- 4 Pitch-Systems

SC SGP PG
2,7V
65°C

higher voltage →

SC SGE EG
3V
65°C

SC HBR BR
500 000 cycles
-15°C ~ 70°C

→ wider temperature range →

SC HBRL BL
250 000 cycles
-25°C ~ 70°C

↓ higher capacitance ↓

SC HBE BE
250 000 cycles
-25°C ~ 70°C

APPLICATIONS:

- 1 Smartmetering
- 2 UPS (longer holding times than EDLC)
- 3 Powertools
- 4 Energy harvesting

RADIAL

SC HAA AA
2,5V ~ 4V
-25°C ~ 55°C

↓ higher capacitance ↓

SC HAE AE
2,5V ~ 4V
-25°C ~ 55°C

APPLICATIONS:

- 1 AGV
- 2 Elevator
- 3 e-mobility
- 4 UPS (High Power and High Energy)
- 5 traction

POUCH



- High power density
- High energy density
- Welded column terminal
- New improved cell design

APPLICATIONS:

- 1 AGV
- 2 Elevator
- 3 e-mobility
- 4 UPS (High Power and High Energy)
- 5 traction

AXIAL/
WELDED COLUMN



EDLC & LiC

Modules are always customer specific. Please contact Alexander Schedlock for further information:

a.schedlock@jianghai-europe.com

MODULES

GOOD TO KNOW:

Not in the mood for paper?

In that case, feel free to use the
product search on our website!



<https://jianghai-europe.com/productsearch>

RADIAL SINGLE CELL TYPE

 EDLC: Order Code RADIAL SINGLE CELL 16

 EDLC: Technical Specifications RADIAL SINGLE CELL 17

SERIES	CODE	TYPE	TEMPERATURE RANGE	VOLTAGE	INFO	
SC SRP	PR	RADIAL SINGLE CELL	-40 ~ +70°C	2,7V	Standard	18
SC SRE	ER	RADIAL SINGLE CELL	-40 ~ +65°C	3V	Enlarged Voltage Range	20
SC SRQ	QR	RADIAL SINGLE CELL	-40 ~ +85°C	2,7V	Higher Temperature Range	22

RADIAL MULTI CELL TYPE

 EDLC: Order Code RADIAL MULTI CELL 24

 EDLC: Technical Specifications RADIAL MULTI CELL 25

SERIES	CODE	TYPE	TEMPERATURE RANGE	VOLTAGE	INFO	
SC SRM	MR	RADIAL MULTI CELL	-40 ~ +70°C	5,5V	Standard	28
SC SRS	SR	RADIAL MULTI CELL	-40 ~ +65°C	6V	Higher Voltage	30
SC SRO	OR	RADIAL MULTI CELL	-40 ~ +85°C	5,5V	Higher Temperature Range	32

SNAP-IN TYPE

 EDLC: Order Code SNAP-IN 34

 EDLC: Technical Specifications SNAP-IN 35

SERIES	CODE	TYPE	TEMPERATURE RANGE	VOLTAGE	INFO	
SC SSP	PS	SNAP-IN	-40 ~ +65°C	2,7V	Standard	36
SC SSE	ES	SNAP-IN	-40 ~ +65°C	3V	Higher Voltage	37
SC SSL	LS	SNAP-IN	-40 ~ +65°C	2,7V	Higher Capacitance	38

WELDED COLUM TYPE

SERIES	CODE	TYPE	TEMPERATURE RANGE	VOLTAGE	INFO	
SC SSL-J	LS	WELDED COLUMN	-40 ~ +60°C	3V	High Current	39

AXIAL TYPE

 EDLC: Order Code AXIAL 40

 EDLC: Technical Specifications AXIAL 40

SERIES	CODE	TYPE	TEMPERATURE RANGE	VOLTAGE	INFO	
SC SGP	PG	AXIAL	-40 ~ +65°C	2,7V	Standard	41
SC SGE	EG	AXIAL	-40 ~ +65°C	3V	Higher Voltage	43



SC	C	D	ER	2R7	504	Q	LL	35	1860	E	E3	JExxxxx
Technology	Design Code	Energy-Capacitor Type	Series Code	Rated Voltage Code	Capacitance Code (in F)	Capacitance Tolerance Code	Lead Form Code	Pitch	Dimension øD x h (in mm)	Material Code Sleeve	for internal use	for Specials only
SC = Energy-Capacitor	Single Cell C	EDLC D	SRE ER SRP PR SRQ QR	2,7 2R7 3,0 3R0	0,5 504 1,0 105 3,3 335 10 106 50 506 100 107 120 127 220 227	+30% / -10% Q +20% / -20% M +20% / -0% R	Long Leads LL Taped FF Cut 4,5mm CC	2,0mm 20 2,5mm 25 3,5mm 35 5,0mm 50 5,5mm 55 7,5mm 75 8,0mm 80 12,0mm 12 15,5mm 15 18,0mm 18	5x12 0512 6x12 0612 8x14 0814 8x20 0820 10x16 1016 10x20 1020 10x25 1025 10x30 1030 12,5x25 1225 16x20 1620 16x25 1625 16x50 1650 18x40 1840 18x50 1850 18x60 1860 22x45 2245 22x55 2255	PET E PVC V	E3	
							other style on request					





SINGLE CELL

DIMENSIONS FOR LOOSE, LONG-LEAD TYPE (BULK)

ORDER CODE: LL

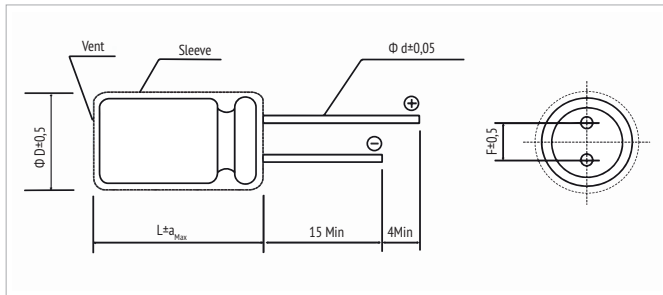

Ø D	5	6,3	8	10	12,5	16	18
F	2,0	2,5	3,5	5,0	7,5		
Ø d	0,5		0,6	0,8			
a _{Max}			2,0				

in mm

DIMENSIONS FOR LOOSE, SHORT CUT LEADS (BULK) EDLC ONLY

ORDER CODE: CC

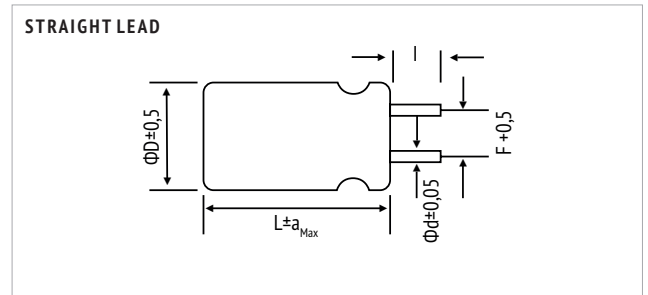

Code	CC
I	4,5 ± 0,5

Other length on request.

in mm

DIMENSIONS FOR AMMOPACK TAPING FOR ELECTROLYTIC CAPACITORS (EDLC ONLY)

ORDER CODE: FF (FD)

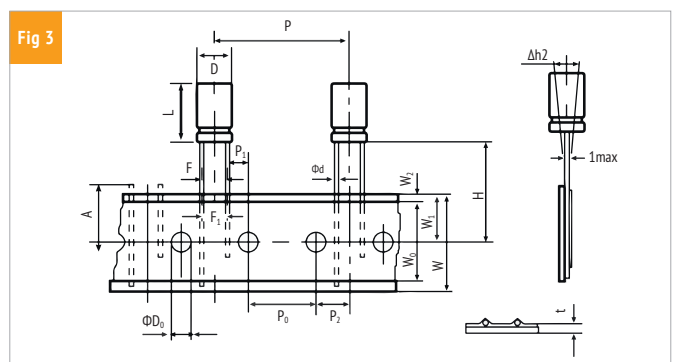
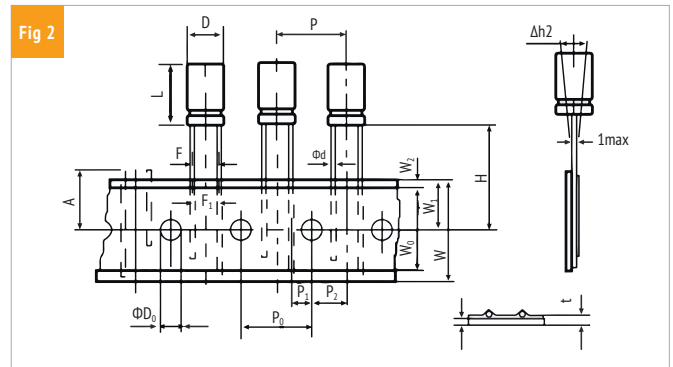
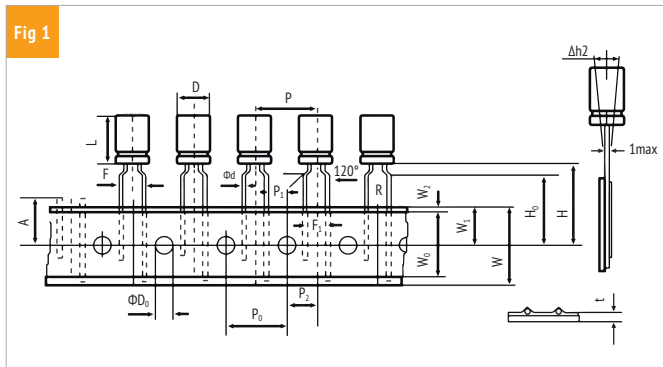

ITEM	D	L	Ød	P	P ₀	P ₁	P ₂	F	F ₁	W	W ₀	W ₁	W ₂	H	H ₀	A	ØD ₀	Δh ₂	t	Fig.	Taping Code	
ToL.	± 0,5	± 2,0	± 0,05	± 1,0	± 0,2	± 0,5	± 1,0	+ 0,8 - 0,2	± 1,0	± 0,5	min	± 0,5	max	+ 0,75 - 0,5	± 0,5	max	± 0,5	max	± 0,2			
Nominal	8	11,5-20	0,6	12,7	12,7	4,6 3,85	6,35	3,5 5	3,5 5	18,0	10,0	9,0	1,5	18,5 20,0	- 16,0	11,0	4,0	1,0	0,7	2 1	FF FF	
	10	12,5-36	0,6	12,7	12,7	3,85	6,35	5	5	18,0	10,0	9,0	1,5	18,5	-	11,0	4,0	1,0	0,7	2	FF	
	12,5	15-36	0,6	15	15	5,0	7,5	5	5	18,0	12,0	9,0	1,5	18,5	-	11,0	4,0	1,0	0,7	2	FF	
				25,4	12,7	3,85	6,35													3	FD	
	16	15-31,5	0,8	30	15	3,75	7,5	7,5	7,5	7,5	18,0	12,0	9,0	1,5	18,5	-	11,0	4,0	1,0	0,7	3	FD
	18	15-25,5	0,8	30	15	3,75	7,5	7,5	7,5	7,5	18,0	12,0	9,0	1,5	18,5	-	11,0	4,0	1,0	0,7	3	FD

in mm

Other taping styles available on request.

Other lead types available on request.

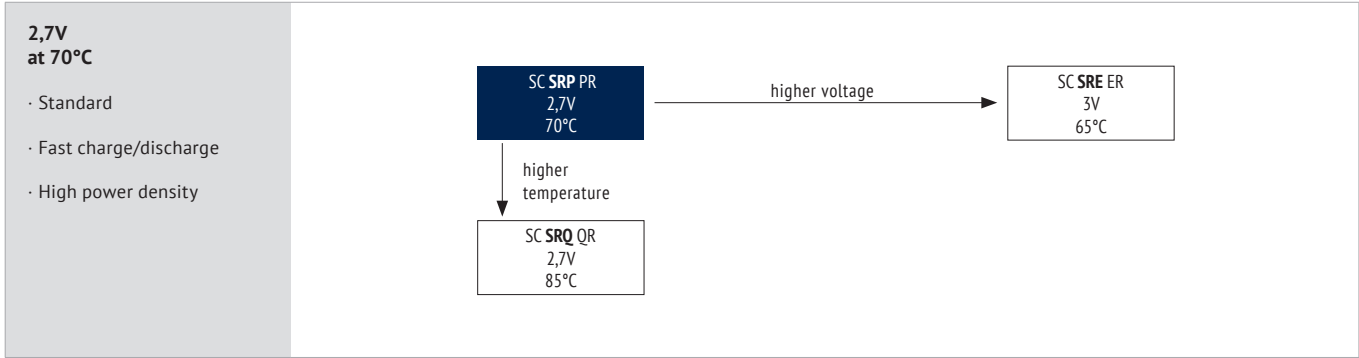

ITEM CHARACTERISTICS

Operating Temperature Range (°C)	-40 ~ +70 (-40 ~ +85 at 2,3V)
Rated Voltage (V)	2,7
Capacitance Range (F)	0,5 ~ 100
Capacitance Tolerance (25°C)	+30/-10%

! The usage at lower temperatures than indicated may be possible. Please contact the Jianghai Europe sales office for approval.

Leakage Current After 72 hours at 25°C application of rated voltage, leakage current is not more than specified in table.

Self Discharge Voltage After 72 hours storage at 25°C, 25-85% RH and initial charging at U_R , the remaining voltage shall be $\geq 2,1V$

Temperature Characteristics	The specification shall be met at upper category temperature of 70°C	Capacitance Change	±10% of initial value
		ESR Change	less than specified value
	The specification shall be met at lower category temperature of -40°C	Capacitance Change	±30% of initial value
		ESR Change	less than 400% of specified value
Load Life	The specification shall be met after $\leq 2,7V$ applies at 70°C for 1 000h*	Capacitance Change	±30% of initial value
		ESR Change	less than 200% of specified value
Cycle Life	The specification shall be met after 500 000 cycles at 25°C; 1 cycle=charge-discharge from U_R to $\frac{1}{2}U_R$	Capacitance Change	±30% of initial value
		ESR Change	less than 200% of specified value

* Load Life (constant voltage) is only allowed between 2,7V and 2,0V at $T_{surface} \leq 70°C$

ENVIRONMENTAL

The products are RoHS, WEEE and REACh compliant. The detailed version please see separate "Environmental Certificates" document or www.jianghai-europe.com



SPECIFICATIONS

U _R	C _R	ESR _{DC,max}	ESR _{AC,max}	I _{leak}	I _r *	I _{MAX}	I _S	Size	Order Code
Rated Voltage Code	Rated Capacitance	Equivalent Series Resistance 25°C	Equivalent Series Resistance 25°C (1kHz)	Leakage Current 25°C (72h)	Rated Current	Max. Continuous Current ΔT15°C	Surge Current <1sec		Details: Page 16
(V)	(F)	(mΩ)	(mΩ)	(μA)	(A)	(A)	(A)	mm DxL	◇◇ = pin style & length
2,7 2R7	0,5	900	450	5	0,015	0,30	0,47	5 x 12	SCCDPR2R7504Q◇◇200512EE3
	1	700	350	6	0,030	0,40	0,79	6,3 x 12	SCCDPR2R7105Q◇◇250612EE3
		400	200	8	0,030	0,50	0,80	8 x 14	SCCDPR2R7105Q◇◇350814EE3
	2	240	120	10	0,060	0,60	1,82	8 x 14	SCCDPR2R7205Q◇◇350814EE3
	3	150	75	12	0,090	0,70	2,79	8 x 20	SCCDPR2R7305Q◇◇350820EE3
	3,3	150	75	14	0,099	0,90	2,98	8 x 20	SCCDPR2R7335Q◇◇350820EE3
	5	120	60	16	0,150	1,20	4,09	10 x 20	SCCDPR2R7505Q◇◇501020EE3
	7	110	55	20	0,210	1,80	5,34	10 x 25	SCCDPR2R7705Q◇◇501025EE3
	10	80	40	30	0,300	2,30	7,50	10 x 30	SCCDPR2R7106Q◇◇501030EE3
		80	40	30	0,300	2,3	7,50	12,5 x 20	SCCDPR2R7106Q◇◇501225EE3
	15	60	30	45	0,450	2,50	10,66	12,5 x 25	SCCDPR2R7156Q◇◇501225EE3
	20	50	25	60	0,600	2,60	13,50	16 x 20	SCCDPR2R7206Q◇◇751620EE3
	25	44	22	80	0,750	2,80	16,07	16 x 25	SCCDPR2R7256Q◇◇751625EE3
	50	32	16	140	1,500	5,50	25,96	18 x 40	SCCDPR2R7506Q◇◇751840EE3
	60	32	16	140	1,800	5,80	27,74	18 x 40	SCCDPR2R7606Q◇◇751840EE3
70	36	18	160	2,100	6,30	26,85	18 x 50	SCCDPR2R7706Q◇◇751850EE3	
100	32	16	180	3,000	6,60	32,14	18 x 60	SCCDPR2R7107Q◇◇751860EE3	

■ = preferred

 *Rated current I_R = 40°I_R = 40°C*U_R/3600 (IEC 62391-1)

ENERGY STORAGE

U _R	C _R	E	Weight	Specific Energy Density	Power Density (IPM)	Order Code
Rated Voltage Code	Rated Capacitance	Stored Energy				Details: Page 16
(V)	(F)	(Wh)	(g)	(Wh/kg)	(kW/kg)	◇◇ = pin style & length
2,7 2R7	0,5	<0,001	0,4	1,27	5,06	SCCDPR2R7504Q◇◇200512EE3
	1	0,001	0,66	1,53	3,94	SCCDPR2R7105Q◇◇250612EE3
		0,001	0,9	1,13	2,53	SCCDPR2R7105Q◇◇350814EE3
	2	0,002	1,0	2,03	7,59	SCCDPR2R7205Q◇◇350814EE3
	3	0,003	1,4	2,17	8,68	SCCDPR2R7305Q◇◇350820EE3
	3,3	0,003	1,5	2,23	8,10	SCCDPR2R7335Q◇◇350820EE3
	5	0,005	2,1	2,41	6,68	SCCDPR2R7505Q◇◇501020EE3
	7	0,007	2,7	2,63	6,14	SCCDPR2R7705Q◇◇501025EE3
	10	0,010	3,2	3,16	7,12	SCCDPR2R7106Q◇◇501030EE3
		0,010	3,4	2,98	6,70	SCCDPR2R7106Q◇◇501225EE3
	15	0,015	4,3	3,53	7,06	SCCDPR2R7156Q◇◇501225EE3
	20	0,020	5,9	3,43	6,18	SCCDPR2R7206Q◇◇751620EE3
	25	0,025	7,4	3,42	5,60	SCCDPR2R7256Q◇◇751625EE3
	50	0,051	13,0	3,89	4,38	SCCDPR2R7506Q◇◇751840EE3
	60	0,061	13,6	4,47	4,19	SCCDPR2R7606Q◇◇751840EE3
70	0,071	17,0	4,17	2,98	SCCDPR2R7706Q◇◇751850EE3	
100	0,101	19,0	5,33	3,00	SCCDPR2R7107Q◇◇751860EE3	

■ = preferred

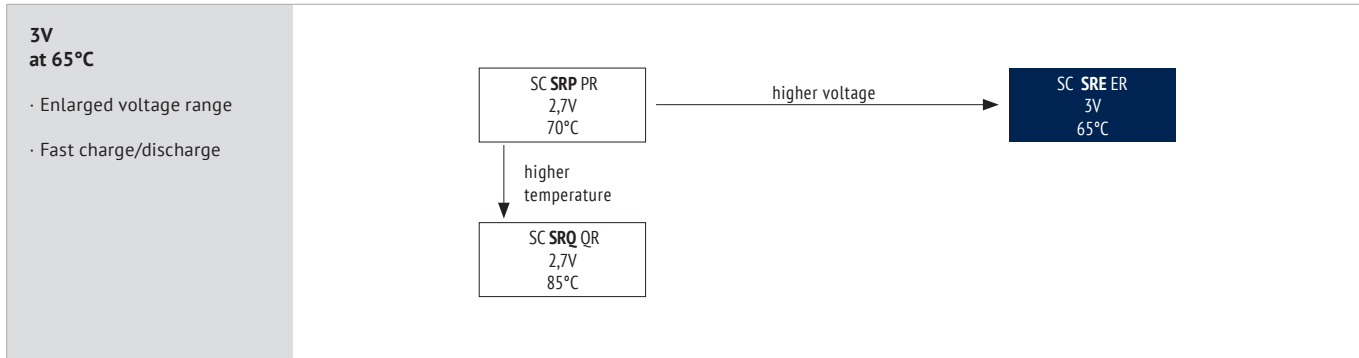

ITEM CHARACTERISTICS

Operating Temperature Range (°C)	-40 ~ +65 (-40 ~ +85 at 2,4V)
Rated Voltage (V)	3
Capacitance Range (F)	0,5 ~ 180
Capacitance Tolerance (25°C)	+30/-10%

! The usage at lower temperatures than indicated may be possible. Please contact the Jianghai Europe sales office for approval.

Leakage Current After 72 hours at 25°C application of rated voltage, leakage current is not more than specified in table.

Self Discharge Voltage After 72 hours storage at 25°C, 25~85% RH and initial charging at U_R , the remaining voltage shall be $\geq 2,3V$

Temperature Characteristics	The specification shall be met at upper category temperature of 65°C	Capacitance Change	±10% of initial value
		ESR Change	less than specified value
	The specification shall be met at lower category temperature of -40°C	Capacitance Change	±30% of initial value
		ESR Change	less than 400% of specified value
Load Life	The specification shall be met after $\leq 3,0V$ applied at 65°C for 1 000h*	Capacitance Change	±30% of initial value
		ESR Change	less than 400% of specified value
Cycle Life	The specification shall be met after 500 000 cycles at 25°C; 1 cycle=charge-discharge from U_R to $\frac{1}{2}U_R$	Capacitance Change	±30% of initial value
		ESR Change	less than 400% of specified value

* Load Life (constant voltage) is only allowed between 3,0V and 2,0V at $T_{surface} \leq 65°C$

ENVIRONMENTAL

The products are RoHS, WEEE and REACH compliant. The detailed version please see separate "Environmental Certificates" document or www.jianghai-europe.com

SPECIFICATIONS

U _R	C _R	ESR _{DC,max}	ESR _{AC,max}	I _{leak}	I _r *	I _{max}	I _s	Size	Order Code
Rated Voltage Code	Rated Capacitance	Equivalent Series Resistance 25°C	Equivalent Series Resistance 25°C (1kHz)	Leakage Current 25°C (72h)	Rated Current	Max. Continuous Current ΔT15°C	Surge Current <1sec		Details: Page 16
(V)	(F)	(mΩ)	(mΩ)	(μA)	(A)	(A)	(A)	mm DxL	◊◊ = pin style & length
3 3R0	0,5	800	400	6	0,017	0,50	0,54	5 x 12	SCCDER3R0504Q◊◊200512EE3
	1	1 000	500	8	0,033	0,75	0,75	6,3 x 12	SCCDER3R0105Q◊◊250612EE3
		800	400	10	0,033	0,75	0,80	8 x 14	SCCDER3R0105Q◊◊350820EE3
	3,3	160	80	16	0,110	0,75	3,04	8 x 20	SCCDER3R0335Q◊◊350820EE3
	5	140	70	18	0,167	1,40	4,41	10 x 20	SCCDER3R0505Q◊◊501020EE3
	7	120	60	25	0,233	2,10	5,71	10 x 25	SCCDER3R0705Q◊◊501025EE3
	10	100	50	40	0,333	2,50	7,50	10 x 30	SCCDER3R0106Q◊◊501030EE3
	15	70	35	55	0,500	2,70	10,90	12,5 x 25	SCCDER3R0156Q◊◊501225EE3
	25	50	25	80	0,833	3,10	16,67	16 x 25	SCCDER3R0256Q◊◊751625EE3
	35	42	21	150	1,167	4,00	21,26	16 x 35	SCCDER3R0356Q◊◊751635EE3
	40	42	21	250	1,333	4,80	22,39	16 x 35	SCCDER3R0406Q◊◊751635EE3
	50	40	20	300	1,667	5,90	25,00	18 x 40	SCCDER3R0506Q◊◊751840EE3
	60	40	20	350	2,000	6,00	26,47	18 x 40	SCCDER3R0606Q◊◊751840EE3
	70	40	20	500	2,333	6,20	27,60	18 x 40	SCCDER3R0706Q◊◊751840EE3
100	36	18	550	3,333	9,80	32,60	18 x 60	SCCDER3R0107Q◊◊751860EE3	
120	36	18	700	4,000	10,50	33,83	18 x 60	SCCDER3R0127Q◊◊751860EE3	
180	16	10	900	6,000	12,00	69,00	22 x 55	SCCDER3R0187Q◊◊102255EE3	

◻ = preferred

 *Rated current I_r = 40°I_r = 40°C × U_R/3600 (IEC 62391-1)

ENERGY STORAGE

U _R	C _R	E	Weight	Specific Energy Density	Power Density (IPM)	Order Code
Rated Voltage Code	Rated Capacitance	Stored Energy				Details: Page 16
(V)	(F)	(Wh)	(g)	(Wh/kg)	(kW/kg)	◊◊ = pin style & length
3 3R0	0,5	<0,001	0,4	1,56	7,03	SCCDER3R0504Q◊◊200512EE3
	1	0,001	0,66	1,89	3,41	SCCDER3R0105Q◊◊250612EE3
		0,001	0,9	1,40	3,10	SCCDER3R0105Q◊◊350820EE3
	3,3	0,004	1,4	2,68	10,04	SCCDER3R0335Q◊◊350820EE3
	5	0,006	2,2	2,84	7,31	SCCDER3R0505Q◊◊501020EE3
	7	0,009	2,8	3,13	6,70	SCCDER3R0705Q◊◊501025EE3
	10	0,013	3,2	3,91	7,03	SCCDER3R0106Q◊◊501030EE3
	15	0,019	4,3	4,36	7,48	SCCDER3R0156Q◊◊501225EE3
	25	0,031	7,5	4,17	6,00	SCCDER3R0256Q◊◊751625EE3
	35	0,044	9,8	4,46	5,47	SCCDER3R0356Q◊◊751635EE3
	40	0,050	9,9	5,05	5,41	SCCDER3R0406Q◊◊751635EE3
	50	0,063	13,5	4,63	4,17	SCCDER3R0506Q◊◊751840EE3
	60	0,075	13,8	5,43	4,08	SCCDER3R0606Q◊◊751840EE3
	70	0,088	13,8	6,34	4,08	SCCDER3R0706Q◊◊751840EE3
100	0,125	19	6,58	3,29	SCCDER3R0107Q◊◊751860EE3	
120	0,150	19	7,89	3,29	SCCDER3R0127Q◊◊751860EE3	
180	0,225	27	8,33	2,50	SCCDER3R0187Q◊◊102255EE3	

◻ = preferred

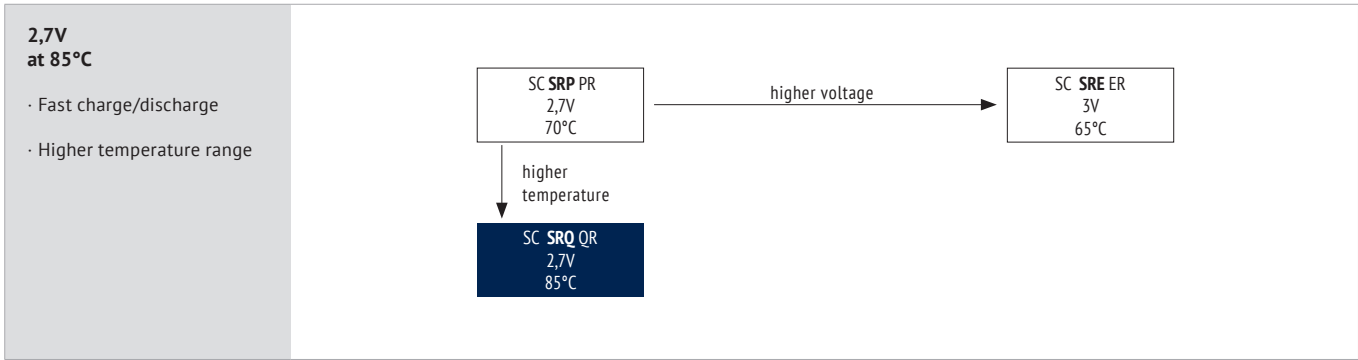

ITEM	CHARACTERISTICS
------	-----------------

Operating Temperature Range (°C)	-40 ~ +85
Rated Voltage (V)	2,7
Capacitance Range (F)	1 ~ 100
Capacitance Tolerance (25°C)	+30/-10%

! The usage at lower temperatures than indicated may be possible. Please contact the Jianghai Europe sales office for approval.

Leakage Current	After 72 hours at 25°C application of rated voltage, leakage current is not more than specified in table.
-----------------	---

Self Discharge Voltage	After 72 hours storage at 25°C, 25~85% RH and initial charging at U_R , the remaining voltage shall be $\geq 2,1V$
------------------------	--

Temperature Characteristics	The specification shall be met at upper category temperature of 85°C	Capacitance Change	±10% of initial value
		ESR Change	less than specified value
	The specification shall be met at lower category temperature of -40°C	Capacitance Change	±30% of initial value
		ESR Change	less than 400% of specified value

Load Life	The specification shall be met after $\leq 2,7V$ applied at 85°C for 1 000h*	Capacitance Change	±30% of initial value
		ESR Change	less than 400% of specified value

Cycle Life	The specification shall be met after 500 000 cycles at 25°C; 1 cycle=charge-discharge from U_R to $\frac{1}{2}U_R$	Capacitance Change	±30% of initial value
		ESR Change	less than 400% of specified value

* Load Life (constant voltage) is only allowed between 2,7V and 2,0V at $T_{surface} \leq 85^\circ C$

ENVIRONMENTAL

The products are RoHS, WEEE and REACH compliant. The detailed version please see separate "Environmental Certificates" document or www.jianghai-europe.com

SPECIFICATIONS

U _R	C _R	ESRDC _{Max}	ESRAC _{Max}	I _{leak}	I _r *	I _{MAX}	I _S	Size	Order Code
Rated Voltage Code	Rated Capacitance	Equivalent Series Resistance 25°C	Equivalent Series Resistance 25°C (1kHz)	Leakage Current 25°C (72h)	Rated Current	Max. Continuous Current ΔT15°C	Surge Current <1sec		Details: Page 16
(V)	(F)	(mΩ)	(mΩ)	(μA)	(A)	(A)	(A)	mm DxL	◇◇ = pin style & length
2,7 2R7	1	1000	500	8	0,030	0,40	0,68	6,3 x 12	SCCDQR2R7105Q◇◇250612EE3
		800	400	8	0,030	0,40	0,75	8 x 14	SCCDQR2R7105Q◇◇350814EE3
	2	320	160	10	0,060	0,60	1,65	8 x 14	SCCDQR2R7205Q◇◇350814EE3
	3,3	160	80	16	0,099	0,80	2,74	8 x 20	SCCDQR2R7335Q◇◇350820EE3
	5	160	80	16	0,150	1,10	3,75	10 x 20	SCCDQR2R7505Q◇◇501020EE3
	7	120	60	20	0,210	1,50	5,14	10 x 25	SCCDQR2R7705Q◇◇501025EE3
	10	100	50	30	0,300	2,20	6,75	10 x 30	SCCDQR2R7106Q◇◇501030EE3
	15	70	35	45	0,450	2,40	9,88	12,5 x 25	SCCDQR2R7156Q◇◇501225EE3
	25	50	25	80	0,750	2,80	15,00	16 x 25	SCCDQR2R7256Q◇◇751625EE3
	35	42	21	150	1,050	3,70	19,10	16 x 35	SCCDQR2R7356Q◇◇751635EE3
	50	40	20	140	1,500	5,40	22,50	18 x 40	SCCDQR2R7506Q◇◇751840EE3
	70	36	18	200	2,100	5,90	26,85	18 x 50	SCCDQR2R7706Q◇◇751850EE3
100	36	18	550	3,000	6,40	29,35	18 x 60	SCCDQR2R7107Q◇◇751860EE3	

■ = preferred

 * Rated current I_k = 40*I_r = 40°C*U_R/3600 (IEC 62391-1)

ENERGY STORAGE

U _R	C _R	E	Weight	Specific Energy Density	Power Density (IPM)	Order Code
Rated Voltage Code	Rated Capacitance	Stored Energy				Details: Page 16
(V)	(F)	(Wh)	(g)	(Wh/kg)	(kW/kg)	◇◇ = pin style & length
2,7 2R7	1	0,001	0,66	1,53	2,76	SCCDQR2R7105Q◇◇250612EE3
		0,001	0,9	1,13	2,53	SCCDQR2R7105Q◇◇350814EE3
	2	0,002	1	2,03	5,70	SCCDQR2R7205Q◇◇350814EE3
	3,3	0,003	1,4	2,17	8,14	SCCDQR2R7335Q◇◇350820EE3
	5	0,005	2,2	2,30	5,18	SCCDQR2R7505Q◇◇501020EE3
	7	0,007	2,7	2,63	5,63	SCCDQR2R7705Q◇◇501025EE3
	10	0,010	3,2	3,16	5,70	SCCDQR2R7106Q◇◇501030EE3
	15	0,015	4,2	3,53	6,05	SCCDQR2R7156Q◇◇501225EE3
	25	0,025	7,4	3,42	4,93	SCCDQR2R7256Q◇◇751625EE3
	35	0,035	9,6	3,69	4,52	SCCDQR2R7356Q◇◇751635EE3
	50	0,051	13,8	3,67	3,30	SCCDQR2R7506Q◇◇751840EE3
	70	0,071	16,9	4,19	3,00	SCCDQR2R7706Q◇◇751850EE3
100	0,101	19	5,33	2,66	SCCDQR2R7107Q◇◇751860EE3	

■ = preferred



SC	M	D	MR	SR5	504	Q	LL	081716	E	TO	HO	12	E3	JExxxx			
Technology	Design Code	Energy-Capacitor Type	Series Code	Rated Voltage Code (in V)	Capacitance Code (in F)	Capacitance Tolerance Code	Terminal Style	Dimension WxLxH (in mm)	Material Code Sleeve	Isolation	Welding Code	Pitch F (in mm)	for internal use	for Specials only			
SC = Energy-Capacitor	Multi Cell	M	EDLC	D	SRM	MR	Long Leads	5,5x11x13	PET	Without isolation	No welding wire	3,5	for internal use	for Specials only			
					SRS	SR		6,5x13x14	Plastic case			4,2					
	SRO	OR	5,5	SR5	0,5	504	+30%/-10%	Q	LL	5,5x11x13	051113	E	T0	HO	3,5	35	
			6	6RO	1,0	105	+20%/-20%	M	6,5x13x14	061314	S					4,2	42
					1,5	155	+20%/-0%	R	8,5x17x16	081716						5	05
					2,5	255			8,5x17x22	081722		Top and Bottom OS	T1			5,5	5R
					3,5	355			11x21x22	112122		Bottom OS	T2			8	08
					5	505			11x21x27	112127						9	09
					10	106			13x26x27	132627		Top OS	T3			11	11
					15	156			17x33x24	173324		Top and Bottom BS	T4			12	12
					25	256			17x33x35	173335		Bottom BS	T5			15,5	15
					50	506			18x37x43	183743		Top BS	T6			18	18
								18x37x62	183762						24	24	
															26	26	

OS = on sleeve
BS = below sleeve





MULTI CELL

T0 (STANDARD), NO ISOLATION

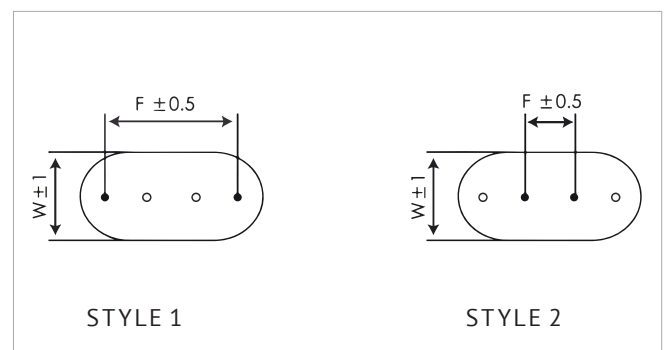
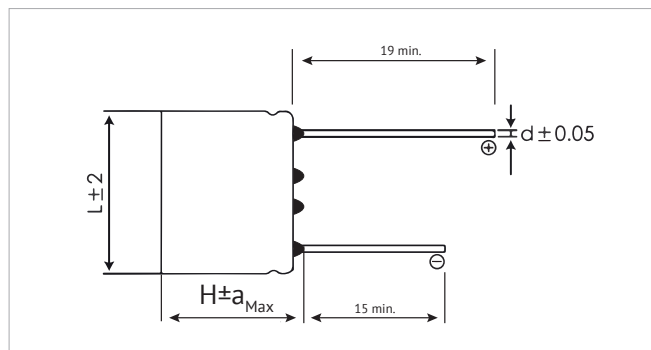
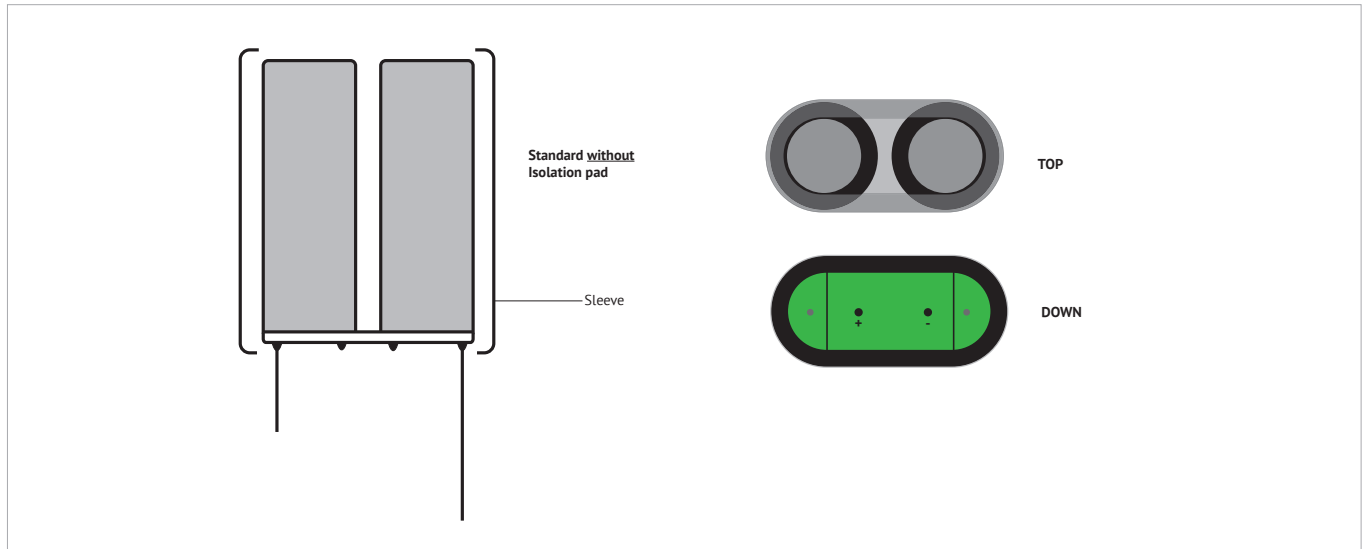

Other leadtypes available on request.

Ø W	5,5		6,5		8,5		11,0		13,0		17,0		18,0			
F	3,5	7,5	4,2	9,0	5,0	12,0	5,5	15,5	8,0	18,0	9,0	24,0	11,0	26,0		
Ø d	0,5				0,6				0,8							
a _{Max}					2,0											

in mm

T1, DOUBLE ISOLATION

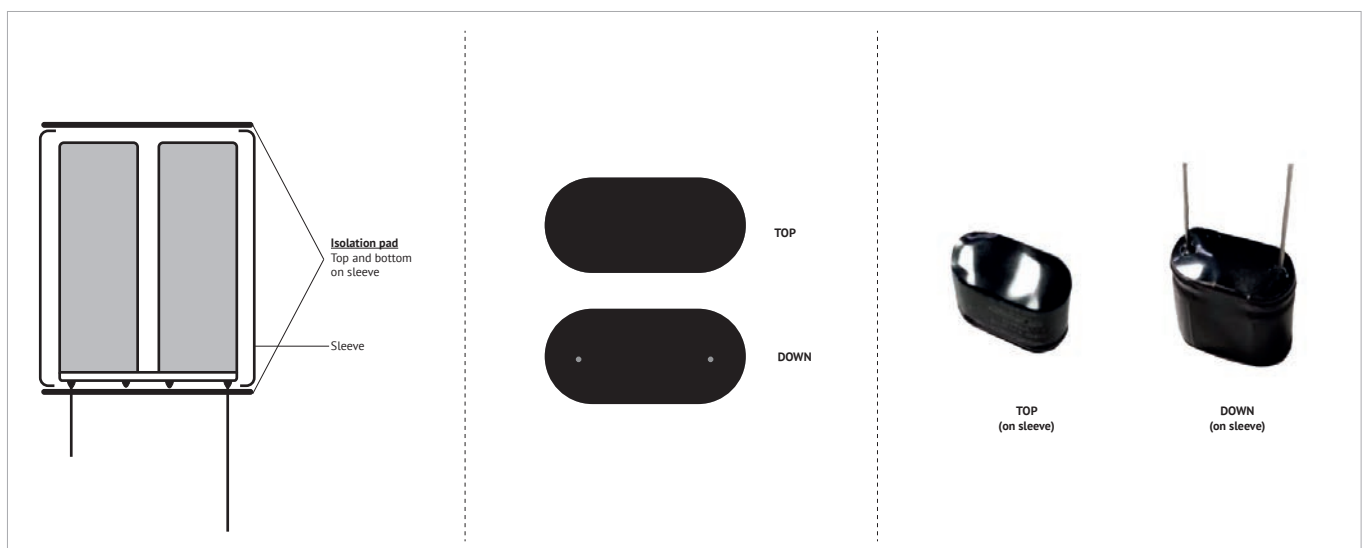



T2

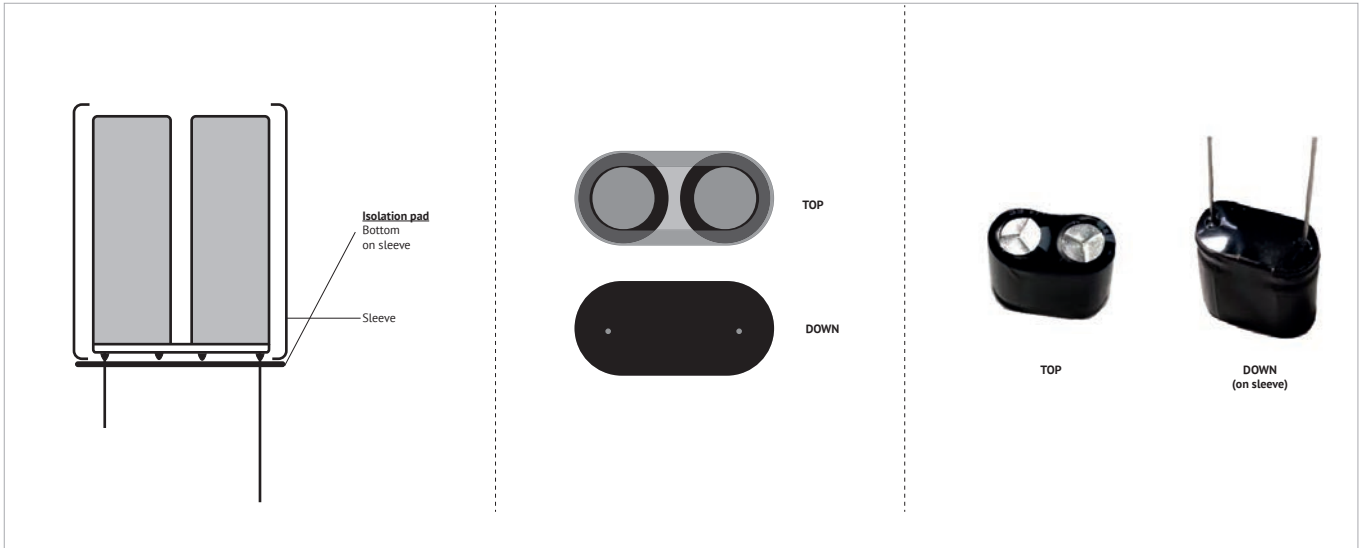

T3

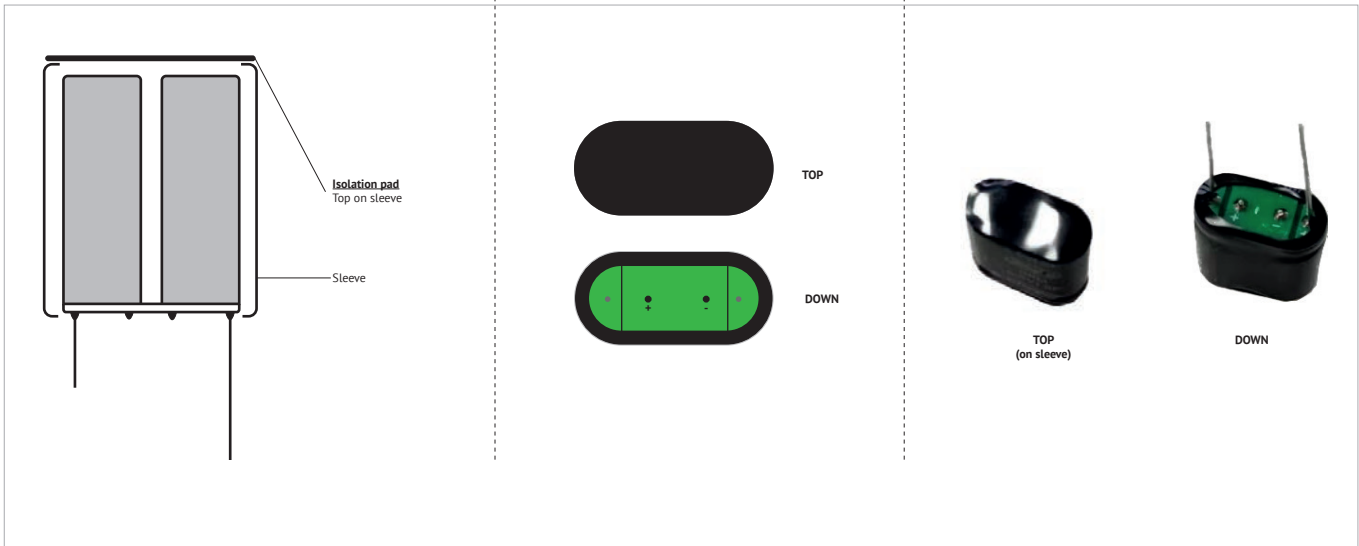

T4

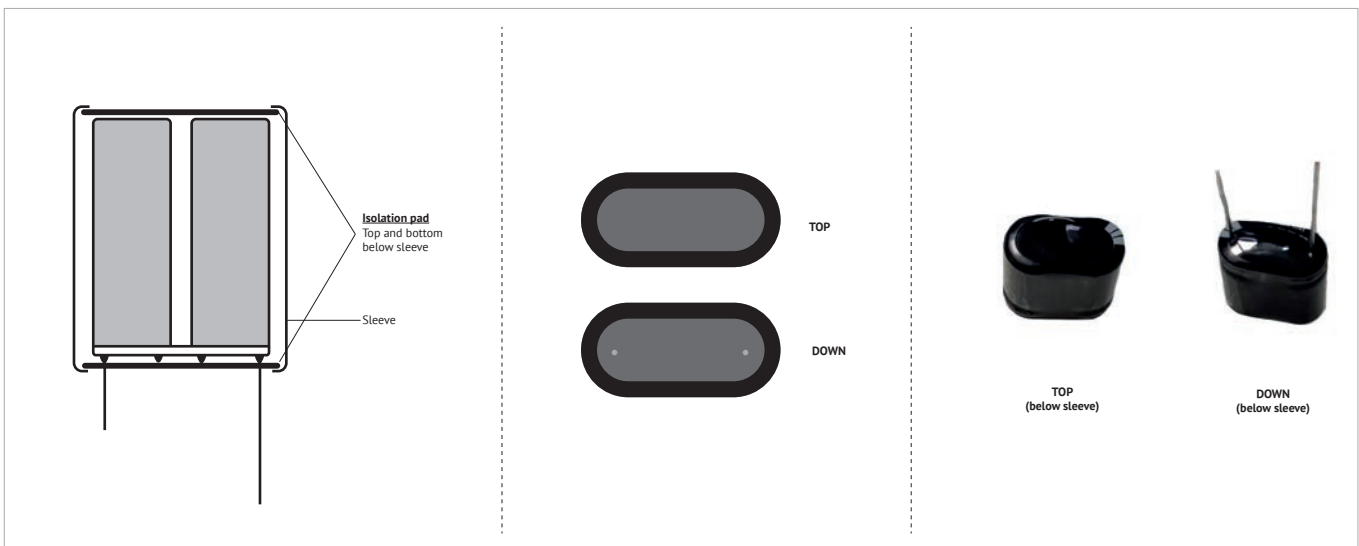

EDLC · RADIAL MULTI





T5

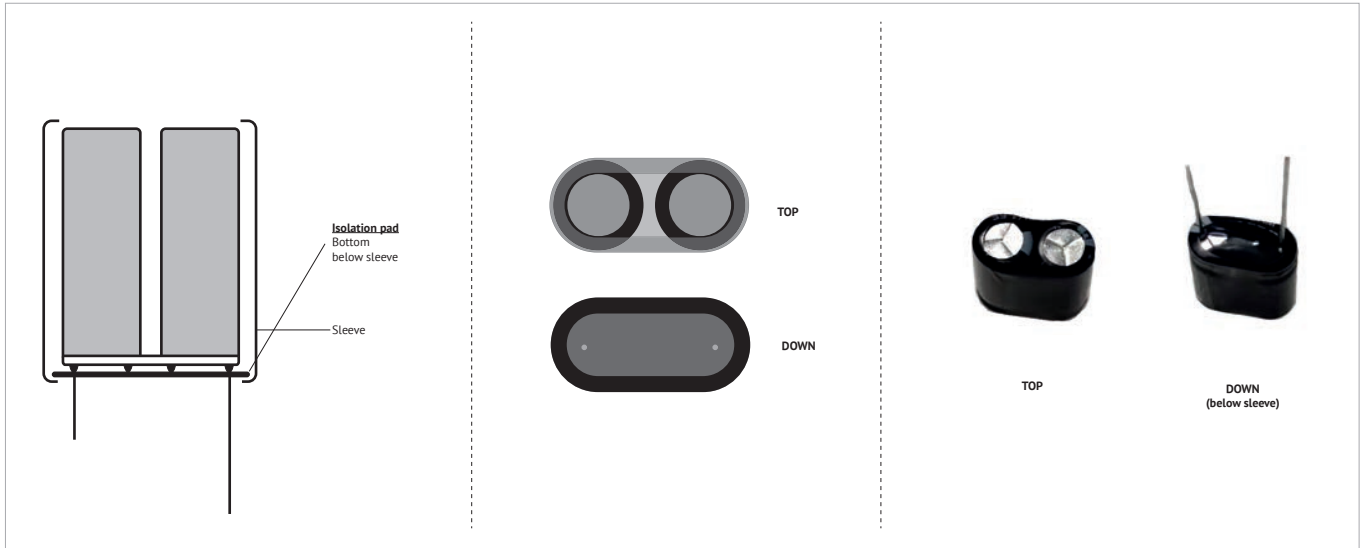

T6

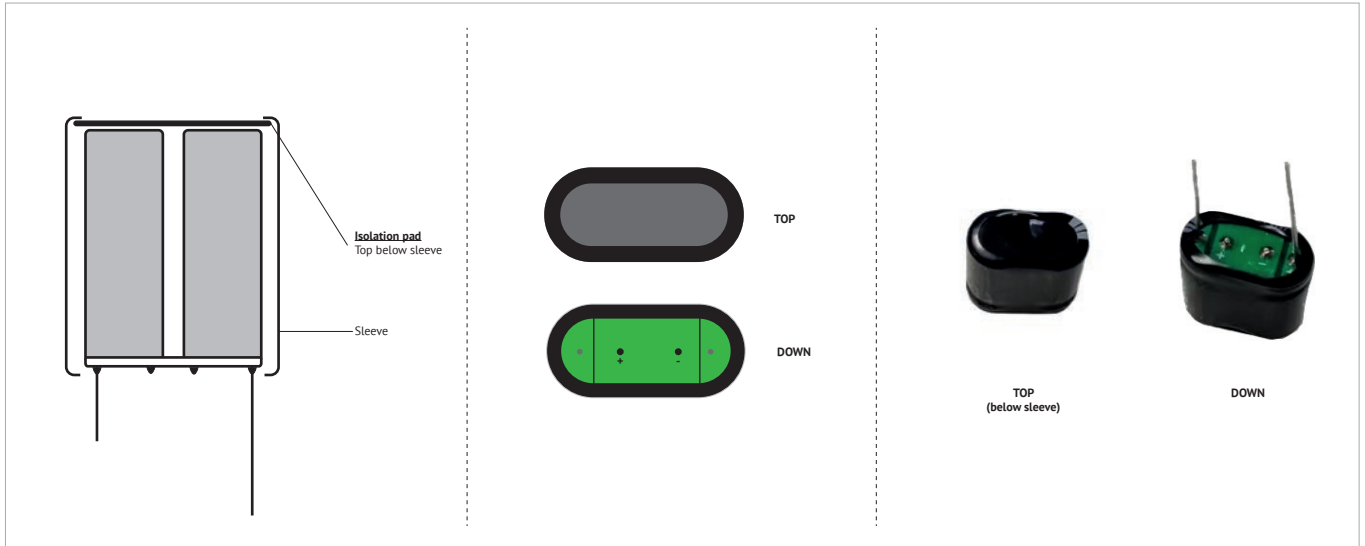

S (SLEEVING TYPE THB), COMPOUND MASS



- > HARD CASE
- > COMPOUND FILLING
- > ON REQUEST

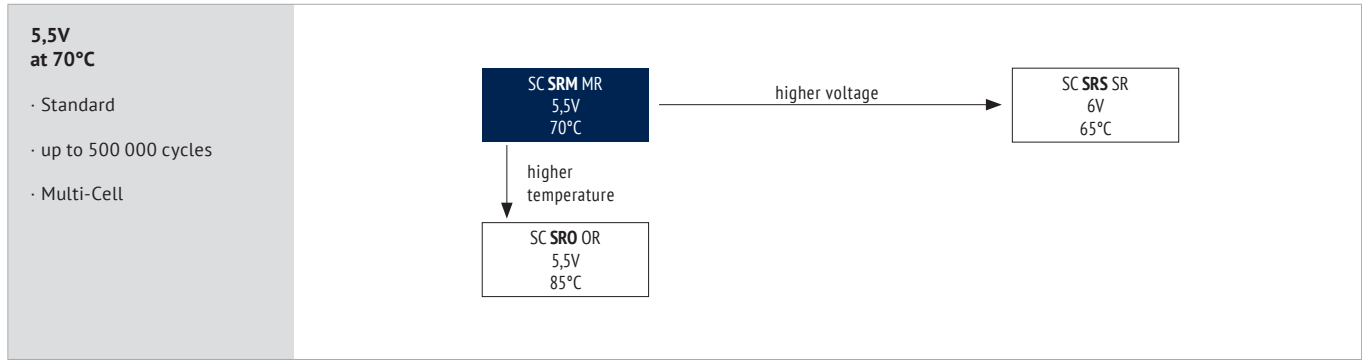

ITEM CHARACTERISTICS

Operating Temperature Range (°C)	-40 ~ +70 (-40 ~ +85 at 4,6V)
Rated Voltage (V)	5,5
Capacitance Range (F)	0,22 ~ 50
Capacitance Tolerance (25°C)	+30/-10%

! The usage at lower temperatures than indicated may be possible. Please contact the Jianghai Europe sales office for approval.

Leakage Current: After 72 hours at 25°C application of rated voltage, leakage current is not more than specified in table.

Self Discharge Voltage: After 72 hours storage at 25°C, 25-85% RH and initial charging at U_R , the remaining voltage shall be $\geq 4,0V$

Temperature Characteristics	The specification shall be met at upper category temperature of 70°C	Capacitance Change	±10% of initial value
		ESR Change	less than specified value
	The specification shall be met at lower category temperature of -40°C	Capacitance Change	±30% of initial value
		ESR Change	less than 400% of specified value
Load Life	The specification shall be met after $\leq 5,5V$ applied at 70°C for 1 000h*	Capacitance Change	±30% of initial value
		ESR Change	less than 200% of specified value
Cycle Life	The specification shall be met after 500 000 cycles at 25°C; 1 cycle=charge-discharge from U_R to $\frac{1}{2}U_R$	Capacitance Change	±30% of initial value
		ESR Change	less than 200% of specified value

* Load Life (constant voltage) is only allowed between 5,5V and 4,0V at $T_{surface} \leq 70°C$

ENVIRONMENTAL

The products are RoHS, WEEE and REACh compliant. The detailed version please see separate "Environmental Certificates" document or www.jianghai-europe.com

EDLC · RADIAL MULTI

SPECIFICATIONS

U _R Rated Voltage Code (V)	C _R Rated Capacitance (F)	ESR _{DC,max} Equivalent Series Resistance 25°C	ESR _{AC,max} Equivalent Series Resistance 25°C (1kHz)	I _{leak} Leakage Current 25°C (72h)	I _{r*} Rated Current	I _{MAX} Max. Continuous Current ΔT15°C	I _s Surge Current 30°C <1sec	Size (mm)			Pitch (mm)	Order Code Details: Page 24 ◇◇ = pin style & length
		(mΩ)	(mΩ)	(μA)	(A)	(A)	(A)	W	L	H		
5,5 SR5	0,22	1 800	900	5	0,01	0,20	0,43	5,5	11	13	7,5	SCMDMR5R5224Q◇◇051113ETOH075E3
		1 800	900	5	0,01	0,20	0,43	5,5	11	13	3,5	SCMDMR5R5224Q◇◇051113ETOH035E3
	0,33	1 420	720	6	0,02	0,30	0,62	6,5	13	14	9	SCMDMR5R5334Q◇◇061314ETOH090E3
		1 420	720	6	0,02	0,30	0,62	6,5	13	14	4,5	SCMDMR5R5334Q◇◇061314ETOH045E3
	0,5	820	420	8	0,03	0,50	0,97	8,5	17,0	16,0	12,0	SCMDMR5R5504Q◇◇081716ETOH012E3
		820	420	8	0,03	0,50	0,97	8,5	17,0	16,0	5,0	SCMDMR5R5504Q◇◇081716ETOH005E3
	1	500	260	10	0,06	0,60	1,83	8,5	17,0	16,0	12,0	SCMDMR5R5105Q◇◇081716ETOH012E3
		500	260	10	0,06	0,60	1,88	8,5	17,0	16,0	5,0	SCMDMR5R5105Q◇◇081716ETOH005E3
	1,5	320	170	12	0,09	0,70	2,79	8,5	17,0	22,0	12,0	SCMDMR5R5155Q◇◇081722ETOH012E3
		320	170	12	0,09	0,70	2,79	8,5	17,0	22,0	5,0	SCMDMR5R5155Q◇◇081722ETOH005E3
	2,5	260	140	16	0,15	1,20	4,17	11,0	21,0	22,0	15,5	SCMDMR5R5255Q◇◇112122ETOH015E3
		260	140	16	0,15	1,20	4,17	11,0	21,0	22,0	5,5	SCMDMR5R5255Q◇◇112122ETOH05RE3
	3,5	240	130	20	0,21	1,80	5,23	11,0	21,0	27,0	15,5	SCMDMR5R5355Q◇◇112127ETOH015E3
		240	130	20	0,21	1,80	5,23	11,0	21,0	27,0	5,5	SCMDMR5R5355Q◇◇112127ETOH05RE3
	5	180	100	30	0,30	2,30	7,24	13,0	26,0	27,0	18,0	SCMDMR5R5505Q◇◇132627ETOH018E3
		180	100	30	0,30	2,30	7,24	13,0	26,0	27,0	8,0	SCMDMR5R5505Q◇◇132627ETOH008E3
	10	120	70	60	0,60	2,60	12,50	17,0	33,0	24,0	24,0	SCMDMR5R5106Q◇◇173324ETOH024E3
		120	70	60	0,60	2,60	12,50	17,0	33,0	24,0	9,0	SCMDMR5R5106Q◇◇173324ETOH009E3
	15	92	56	100	0,92	3,40	17,33	17,0	33,0	35,0	24,0	SCMDMR5R5156Q◇◇173335ETOH024E3
		92	56	100	0,92	3,40	17,33	17,0	33,0	35,0	9,0	SCMDMR5R5156Q◇◇173335ETOH009E3
25	84	52	140	1,53	5,50	22,18	18,0	37,0	43,0	26,0	SCMDMR5R5256Q◇◇183743ETOH026E3	
	84	52	140	1,53	5,50	22,18	18,0	37,0	43,0	11,0	SCMDMR5R5256Q◇◇183743ETOH011E3	
50	84	52	180	3,06	6,60	26,44	18,0	37,0	62,0	26,0	SCMDMR5R5506Q◇◇183762ETOH026E3	
	84	52	180	3,06	6,60	26,44	18,0	37,0	62,0	11,0	SCMDMR5R5506Q◇◇183762ETOH011E3	

■ = preferred

 * Rated current I_r = 40°I_r = 40°Cx°U_R/3600 (IEC 62391-1)

ENERGY STORAGE

U _R Rated Voltage Code (V)	C _R Rated Capacitance (F)	E Stored Energy (Wh)	Weight (g)	Specific Energy Density (Wh/kg)	Power Density (IPM) (kW/kg)	Order Code Details: Page 24 ◇◇ = pin style & length
5,5 SR5	0,22	0,001	0,9	1,02	4,67	SCMDMR5R5224Q◇◇051113ETOH075E3
		0,001	0,9	1,02	4,67	SCMDMR5R5224Q◇◇051113ETOH035E3
	0,33	0,001	1,5	0,93	3,55	SCMDMR5R5334Q◇◇061314ETOH090E3
		0,001	1,5	0,93	3,55	SCMDMR5R5334Q◇◇061314ETOH045E3
	0,5	0,002	2	1,05	4,61	SCMDMR5R5504Q◇◇081716ETOH012E3
		0,002	2	1,05	4,61	SCMDMR5R5504Q◇◇081716ETOH005E3
	1	0,004	2,5	1,68	6,05	SCMDMR5R5105Q◇◇081716ETOH012E3
		0,004	2,5	1,68	6,05	SCMDMR5R5105Q◇◇081716ETOH005E3
	1,5	0,006	3,5	1,80	6,75	SCMDMR5R5155Q◇◇081722ETOH012E3
		0,006	3,5	1,80	6,75	SCMDMR5R5155Q◇◇081722ETOH005E3
	2,5	0,011	5	2,10	5,82	SCMDMR5R5255Q◇◇112122ETOH015E3
		0,011	5	2,10	5,82	SCMDMR5R5255Q◇◇112122ETOH05RE3
	3,5	0,015	6	2,45	5,25	SCMDMR5R5355Q◇◇112127ETOH015E3
		0,015	6	2,45	5,25	SCMDMR5R5355Q◇◇112127ETOH05RE3
	5	0,021	8	2,63	5,25	SCMDMR5R5505Q◇◇132627ETOH018E3
		0,021	8	2,63	5,25	SCMDMR5R5505Q◇◇132627ETOH008E3
	10	0,042	13,0	3,23	4,85	SCMDMR5R5106Q◇◇173324ETOH024E3
		0,042	13,0	3,23	4,85	SCMDMR5R5106Q◇◇173324ETOH009E3
	15	0,063	19,0	3,32	4,33	SCMDMR5R5156Q◇◇173335ETOH024E3
		0,063	19,0	3,32	4,33	SCMDMR5R5156Q◇◇173335ETOH009E3
25	0,105	28,5	3,69	3,16	SCMDMR5R5256Q◇◇183743ETOH026E3	
	0,105	28,5	3,69	3,16	SCMDMR5R5256Q◇◇183743ETOH011E3	
50	0,210	40,0	5,25	2,25	SCMDMR5R5506Q◇◇183762ETOH026E3	
	0,210	40,0	5,25	2,25	SCMDMR5R5506Q◇◇183762ETOH011E3	

■ = preferred

EDLC · RADIAL MULTI



6,0V at 65°C

- Higher voltage
- up to 500 000 cycles
- Multi-Cell

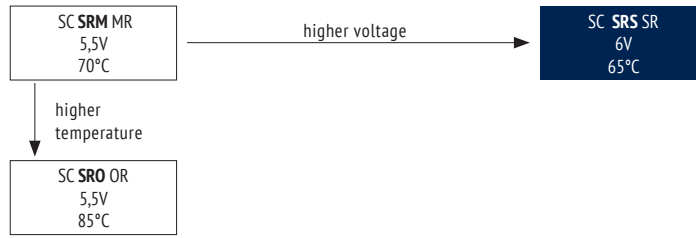

ITEM CHARACTERISTICS

Operating Temperature Range (°C)	-40 ~ +65 (-40 ~ +85 at 5V)
Rated Voltage (V)	6
Capacitance Range (F)	0,5 ~ 50
Capacitance Tolerance (25°C)	+30/-10%

The usage at lower temperatures than indicated may be possible. Please contact the Jianghai Europe sales office for approval.

Leakage Current: After 72 hours at 25°C application of rated voltage, leakage current is not more than specified in table.

Self Discharge Voltage: After 72 hours storage at 25°C, 25-85% RH and initial charging at U_R , the remaining voltage shall be $\geq 4,0V$

Temperature Characteristics	The specification shall be met at upper category temperature of 65°C	Capacitance Change	$\pm 10\%$ of initial value
		ESR Change	less than specified value
	The specification shall be met at lower category temperature of -40°C	Capacitance Change	$\pm 30\%$ of initial value
		ESR Change	less than 400% of specified value
Load Life	The specification shall be met after $\leq 6,0V$ applied at 65°C for 1 000h*	Capacitance Change	$\pm 30\%$ of initial value
		ESR Change	less than 400% of specified value
Cycle Life	The specification shall be met after 500 000 cycles at 25°C; 1 cycle=charge-discharge from U_R to $\frac{1}{2}U_R$	Capacitance Change	$\pm 30\%$ of initial value
		ESR Change	less than 400% of specified value

* Load Life (constant voltage) is only allowed between 6,0V and 4,0V at $T_{surface} \leq 65^\circ C$

ENVIRONMENTAL

The products are RoHS, WEEE and REACH compliant. The detailed version please see separate "Environmental Certificates" document or www.jianghai-europe.com

EDLC · RADIAL MULTI



SPECIFICATIONS

U _R Rated Voltage Code (V)	C _R Rated Capacitance (F)	ESR _{DC, max}	ESR _{AC, max}	I _{leak}	I _{r*}	I _{MAX}	I _s	Size			Pitch	Order Code Details: Page 24 ◇◇ = pin style & length
		Equivalent Series Resistance 25°C	Equivalent Series Resistance 25°C (1kHz)	Leakage Current 25°C (72h)	Rated Current (A)	Max. Continuous Current ΔT15°C (A)	Surge Current 30°C <1sec (A)	W	L	H	(mm)	
		(mΩ)	(mΩ)	(μA)	(A)	(A)	(A)	(mm)	(mm)	(mm)	(mm)	
6 6R0	0,5	1 600	800	10	0,03	0,50	0,83	8,5	17,0	16,0	12,0	SCMDSR6R0504Q◇◇081716ETOH012E3
		1 600	800	10	0,03	0,50	0,83	8,5	17,0	16,0	5,0	SCMDSR6R0504Q◇◇081716ETOH005E3
	1	660	340	12	0,07	0,60	1,81	8,5	17,0	16,0	12,0	SCMDSR6R0105Q◇◇081716ETOH012E3
		660	340	12	0,07	0,60	1,81	8,5	17,0	16,0	5,0	SCMDSR6R0105Q◇◇081716ETOH005E3
	1,5	420	220	16	0,10	0,70	2,76	8,5	17,0	22,0	12,0	SCMDSR6R0155Q◇◇081722ETOH012E3
		420	220	16	0,10	0,70	2,76	8,5	17,0	22,0	5,0	SCMDSR6R0155Q◇◇081722ETOH005E3
	2,5	300	160	18	0,17	1,20	4,05	11,0	21,0	22,0	15,5	SCMDSR6R0255Q◇◇112122ETOH015E3
		300	160	18	0,17	1,20	4,05	11,0	21,0	22,0	5,5	SCMDSR6R0255Q◇◇112122ETOH05RE3
	3,5	260	140	25	0,23	1,80	5,50	11,0	21,0	27,0	15,5	SCMDSR6R0355Q◇◇112127ETOH015E3
		260	140	25	0,23	1,80	5,50	11,0	21,0	27,0	5,5	SCMDSR6R0355Q◇◇112127ETOH05RE3
	5	220	120	40	0,33	2,30	7,14	13,0	26,0	27,0	18,0	SCMDSR6R0505Q◇◇132627ETOH018E3
		220	120	40	0,33	2,30	7,14	13,0	26,0	27,0	8,0	SCMDSR6R0505Q◇◇132627ETOH008E3
	7,5	160	90	55	0,45	2,40	10,23	13,0	26,0	27,0	18,0	SCMDSR6R0755Q◇◇132627ETOH018E3
		160	90	55	0,45	2,40	10,23	13,0	26,0	27,0	8,0	SCMDSR6R0755Q◇◇132627ETOH008E3
	10	132	76	55	0,67	2,60	12,93	17,0	33,0	24,0	24,0	SCMDSR6R0106Q◇◇173324ETOH024E3
		132	76	55	0,67	2,60	12,93	17,0	33,0	24,0	9,0	SCMDSR6R0106Q◇◇173324ETOH009E3
	15	120	70	120	1,00	3,40	16,07	17,0	33,0	35,0	24,0	SCMDSR6R0156Q◇◇173335ETOH024E3
		120	70	120	1,00	3,40	16,07	17,0	33,0	35,0	9,0	SCMDSR6R0156Q◇◇173335ETOH009E3
	25	100	60	300	1,67	5,50	21,43	18,0	37,0	43,0	26,0	SCMDSR6R0256Q◇◇183743ETOH026E3
		100	60	300	1,67	5,50	21,43	18,0	37,0	43,0	11,0	SCMDSR6R0256Q◇◇183743ETOH011E3
50	92	56	550	3,33	6,60	26,79	18,0	37,0	62,0	26,0	SCMDSR6R0506Q◇◇183762ETOH026E3	
	92	56	550	3,33	6,60	26,79	18,0	37,0	62,0	11,0	SCMDSR6R0506Q◇◇183762ETOH011E3	

■ = preferred

 * Rated current I_r = 40°I_a = 40°C_a*U_R/3600 (IEC 62391-1)

EDLC · RADIAL MULTI
ENERGY STORAGE

U _R Rated Voltage Code (V)	C _R Rated Capacitance (F)	E Stored Energy (Wh)	Weight (g)	Specific Energy Density (Wh/kg)	Power Density (IPM) (kW/kg)	Order Code Details: Page 24 ◇◇ = pin style & length
6 6R0	0,5	0,003	2	1,25	2,81	SCMDSR6R0504Q◇◇081716ETOH012E3
		0,003	2	1,25	2,81	SCMDSR6R0504Q◇◇081716ETOH005E3
	1	0,005	2,5	2,00	5,45	SCMDSR6R0105Q◇◇081716ETOH012E3
		0,005	2,5	2,00	5,45	SCMDSR6R0105Q◇◇081716ETOH005E3
	1,5	0,008	3,5	2,14	6,12	SCMDSR6R0155Q◇◇081722ETOH012E3
		0,008	3,5	2,14	6,12	SCMDSR6R0155Q◇◇081722ETOH005E3
	2,5	0,013	5	2,50	5,29	SCMDSR6R0255Q◇◇112122ETOH015E3
		0,013	5	2,50	5,29	SCMDSR6R0255Q◇◇112122ETOH05RE3
	3,5	0,018	6	2,92	5,77	SCMDSR6R0355Q◇◇112127ETOH015E3
		0,018	6	2,92	5,77	SCMDSR6R0355Q◇◇112127ETOH05RE3
	5	0,025	8	3,13	5,11	SCMDSR6R0505Q◇◇132627ETOH018E3
		0,025	8	3,13	5,11	SCMDSR6R0505Q◇◇132627ETOH008E3
	7,5	0,038	9,5	3,95	5,92	SCMDSR6R0755Q◇◇132627ETOH018E3
		0,038	9,5	3,95	5,92	SCMDSR6R0755Q◇◇132627ETOH008E3
	10	0,050	13,0	3,85	5,24	SCMDSR6R0106Q◇◇173324ETOH024E3
		0,050	13,0	3,85	5,24	SCMDSR6R0106Q◇◇173324ETOH009E3
	15	0,075	19,0	3,95	3,95	SCMDSR6R0156Q◇◇173335ETOH024E3
		0,075	19,0	3,95	3,95	SCMDSR6R0156Q◇◇173335ETOH009E3
	25	0,125	29,0	4,31	3,10	SCMDSR6R0256Q◇◇183743ETOH026E3
		0,125	29,0	4,31	3,10	SCMDSR6R0256Q◇◇183743ETOH011E3
50	0,250	40,0	6,25	2,45	SCMDSR6R0506Q◇◇183762ETOH026E3	
	0,250	40,0	6,25	2,45	SCMDSR6R0506Q◇◇183762ETOH011E3	

■ = preferred

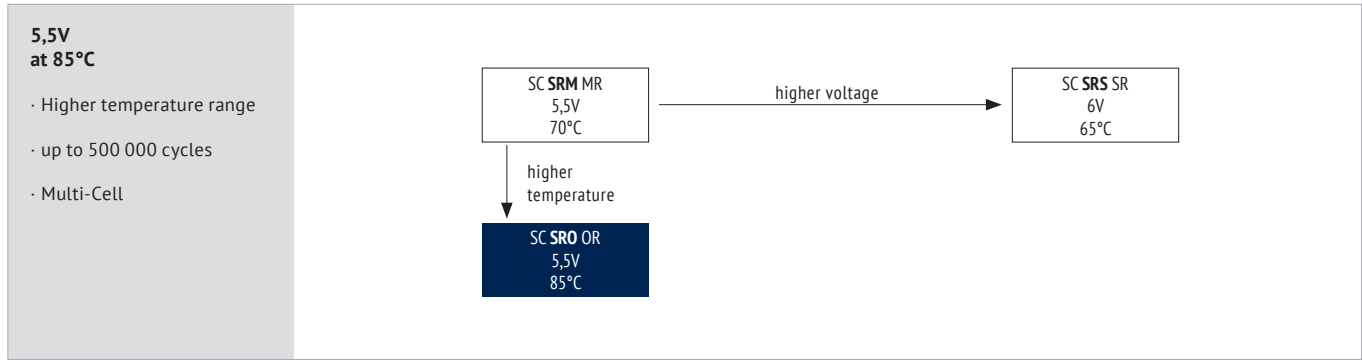

ITEM CHARACTERISTICS

Operating Temperature Range (°C)	-40 ~ +85
Rated Voltage (V)	5,5
Capacitance Range (F)	0,5 ~ 25
Capacitance Tolerance (25°C)	+30/-10%

! The usage at lower temperatures than indicated may be possible. Please contact the Jianghai Europe sales office for approval.

Leakage Current: After 72 hours at 25°C application of rated voltage, leakage current is not more than specified in table.

Self Discharge Voltage: After 72 hours storage at 25°C, 25-85% RH and initial charging at U_R , the remaining voltage shall be $\geq 4,0V$

Temperature Characteristics	The specification shall be met at upper category temperature of 85°C	Capacitance Change	$\pm 10\%$ of initial value
		ESR Change	less than specified value
	The specification shall be met at lower category temperature of -40°C	Capacitance Change	$\pm 30\%$ of initial value
		ESR Change	less than 400% of specified value
Load Life	The specification shall be met after $\leq 5,0V$ applied at 85°C for 1 000h*	Capacitance Change	$\pm 30\%$ of initial value
		ESR Change	less than 400% of specified value
Cycle Life	The specification shall be met after 500 000 cycles at 25°C; 1 cycle=charge-discharge from U_R to $\frac{1}{2}U_R$	Capacitance Change	$\pm 30\%$ of initial value
		ESR Change	less than 400% of specified value

* Load Life (constant voltage) is only allowed between 5,5V and 4,0V at $T_{surface} \leq 85^\circ C$

ENVIRONMENTAL

The products are RoHS, WEEE and REACH compliant. The detailed version please see separate "Environmental Certificates" document or www.jianghai-europe.com

EDLC · RADIAL MULTI

SPECIFICATIONS

U _R Rated Voltage Code (V)	C _R Rated Capacitance (F)	ESR _{DC, max}	ESR _{AC, max}	I _{leak}	I _{r*}	I _{MAX}	I _S	Size			Pitch	Order Code Details: Page 24 ◇◇ = pin style & length
		Equivalent Series Resistance 25°C	Equivalent Series Resistance 25°C (1kHz)	Leakage Current 25°C (72h)	Rated Current (A)	Max. Continuous Current ΔT15°C (A)	Surge Current 30°C <1sec (A)	(mm)			(mm)	
		(mΩ)	(mΩ)	(μA)	(A)	(A)	(A)	W	L	H	(mm)	
5,5 SR5	0,5	1 600	800	8	0,03	0,50	0,76	8,5	17,0	16,0	12,0	SCMDOR5R5504Q◇◇081716ETOH012E3
		1 600	800	8	0,03	0,50	0,76	8,5	17,0	16,0	5,0	SCMDOR5R5504Q◇◇081716ETOH005E3
	1	660	340	10	0,06	0,60	1,66	8,5	17,0	16,0	12,0	SCMDOR5R5105Q◇◇081716ETOH012E3
		660	340	10	0,06	0,60	1,66	8,5	17,0	16,0	5,0	SCMDOR5R5105Q◇◇081716ETOH005E3
	1,5	420	220	16	0,09	0,70	2,53	8,5	17,0	22,0	12,0	SCMDOR5R5155Q◇◇081722ETOH012E3
		420	220	16	0,09	0,70	2,53	8,5	17,0	22,0	5,0	SCMDOR5R5155Q◇◇081722ETOH005E3
	2,5	340	180	16	0,15	1,20	3,72	11,0	21,0	22,0	15,5	SCMDOR5R5255Q◇◇112122ETOH015E3
		340	180	16	0,15	1,20	3,72	11,0	21,0	22,0	5,5	SCMDOR5R5255Q◇◇112122ETOH05RE3
	3,5	260	140	20	0,21	1,80	5,04	11,0	21,0	27,0	15,5	SCMDOR5R5355Q◇◇112127ETOH015E3
		260	140	20	0,21	1,80	5,04	11,0	21,0	27,0	5,5	SCMDOR5R5355Q◇◇112127ETOH05RE3
	5	220	120	30	0,31	2,30	6,55	13,0	26,0	27,0	18,0	SCMDOR5R5505Q◇◇132627ETOH018E3
		220	120	30	0,31	2,30	6,55	13,0	26,0	27,0	8,0	SCMDOR5R5505Q◇◇132627ETOH008E3
	7,5	160	90	45	0,45	2,40	9,38	13,0	26,0	27,0	18,0	SCMDOR5R5755Q◇◇132627ETOH018E3
		160	90	45	0,45	2,40	9,38	13,0	26,0	27,0	8,0	SCMDOR5R5755Q◇◇132627ETOH008E3
	10	132	76	70	0,61	2,60	11,85	17,0	33,0	24,0	24,0	SCMDOR5R5106Q◇◇173324ETOH024E3
		132	76	70	0,61	2,60	11,85	17,0	33,0	24,0	9,0	SCMDOR5R5106Q◇◇173324ETOH009E3
	15	120	70	120	0,92	3,40	14,73	17,0	33,0	35,0	24,0	SCMDOR5R5156Q◇◇173335ETOH024E3
		120	70	120	0,92	3,40	14,73	17,0	33,0	35,0	9,0	SCMDOR5R5156Q◇◇173335ETOH009E3
	25	100	60	140	1,53	5,50	19,64	18,0	37,0	43,0	26,0	SCMDOR5R5256Q◇◇183743ETOH026E3
		100	60	140	1,53	5,50	19,64	18,0	37,0	43,0	11,0	SCMDOR5R5256Q◇◇183743ETOH011E3

■ = preferred

 * Rated current I_r = 40°I_r = 40°C*U_R/3600 (IEC 62391-1)

EDLC · RADIAL MULTI
ENERGY STORAGE

U _R Rated Voltage Code (V)	C _R Rated Capacitance (F)	E	Weight	Specific Energy Density	Power Density (IPM)	Order Code Details: Page 24 ◇◇ = pin style & length
		Stored Energy	(g)	(Wh/kg)	(kW/kg)	
		(Wh)	(g)	(Wh/kg)	(kW/kg)	
5,5 SR5	0,5	0,002	2	1,05	2,36	SCMDOR5R5504Q◇◇081716ETOH012E3
		0,002	2	1,05	2,36	SCMDOR5R5504Q◇◇081716ETOH005E3
	1	0,004	2,5	1,68	4,58	SCMDOR5R5105Q◇◇081716ETOH012E3
		0,004	2,5	1,68	4,58	SCMDOR5R5105Q◇◇081716ETOH005E3
	1,5	0,006	3,5	1,80	5,14	SCMDOR5R5155Q◇◇081722ETOH012E3
		0,006	3,5	1,80	5,14	SCMDOR5R5155Q◇◇081722ETOH005E3
	2,5	0,011	5	2,10	4,45	SCMDOR5R5255Q◇◇112122ETOH015E3
		0,011	5	2,10	4,45	SCMDOR5R5255Q◇◇112122ETOH05RE3
	3,5	0,015	6	2,45	4,85	SCMDOR5R5355Q◇◇112127ETOH015E3
		0,015	6	2,45	4,85	SCMDOR5R5355Q◇◇112127ETOH05RE3
	5	0,021	8	2,63	4,30	SCMDOR5R5505Q◇◇132627ETOH018E3
		0,021	8	2,63	4,30	SCMDOR5R5505Q◇◇132627ETOH008E3
	7,5	0,032	9,5	3,32	4,98	SCMDOR5R5755Q◇◇132627ETOH018E3
		0,032	9,5	3,32	4,98	SCMDOR5R5755Q◇◇132627ETOH008E3
	10	0,042	13,0	3,23	4,41	SCMDOR5R5106Q◇◇173324ETOH024E3
		0,042	13,0	3,23	4,41	SCMDOR5R5106Q◇◇173324ETOH009E3
	15	0,063	19,0	3,32	3,32	SCMDOR5R5156Q◇◇173335ETOH024E3
		0,063	19,0	3,32	3,32	SCMDOR5R5156Q◇◇173335ETOH009E3
	25	0,105	29,0	3,62	2,61	SCMDOR5R5256Q◇◇183743ETOH026E3
		0,105	29,0	3,62	2,61	SCMDOR5R5256Q◇◇183743ETOH011E3

■ = preferred



SC	C	D	PS	2R7	107	Q	T4	P2	2245	E	E3	JExxxx
Technology	Design Code	Energy-Capacitor Type	Series Code	Rated Voltage Code	Capacitance Code (in F)	Capacitance Tolerance Code	Pin Length	Pin	Dimension øD x h	Material Code Sleeve	for internal use	for Specials only
SC = Energy-Capacitor	Cell/Cylindric C	EDLC D	SSP PS SSE ES SSL LS	2,7 2R7 3,0 3R0	60 606 100 107 120 127 150 157 200 207 220 227 350 357 400 407 470 477 1000 108 1200 128	+30% / -10% Q +20% / -20% M +20% / -0% R	6,3mm T/L6 Lug SL	2 Pin P2 4 Pin P4	22x45 2245 25x50 2550 35x50 3550 35x60 3560 35x70 3570 40x70 4070 40x75 4075 40x90 4090 40x105 4010	PET E PVC V	E3	

EDLC · SNAP-IN





2 PIN TYPE: T6P2

in mm

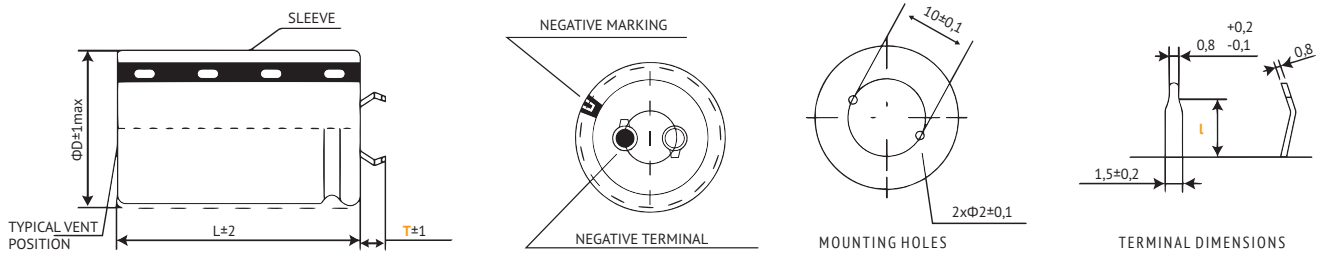

Standard Version: Self-Lock Terminal. Other terminal types and styles on request.
For diameter $\phi D \geq 45\text{mm}$ the safety vent is typically placed at the side of the housing.

Terminal	T6
Pin Length T	6,3 mm
Pin Detail l	3,5 mm

4 PIN TYPE: T6P4

in mm

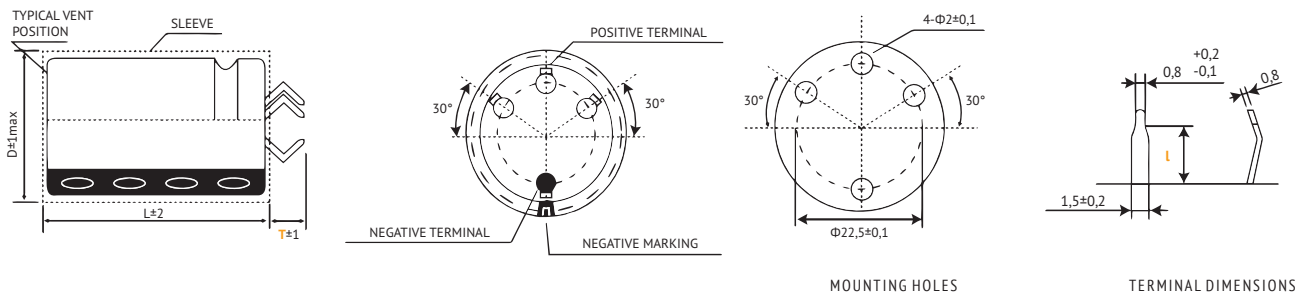

Standard Version: Non-Lock-Terminal. Other terminal types and styles on request.
For $\phi D \geq 30\text{mm}$ only.
For diameter $\phi D \geq 45\text{mm}$ the safety vent is typically placed at the side of the housing.

Terminal	T6 (preferred)
Pin Length T	6,3 mm
Pin Detail l	3,5 mm

LUG-TERMINAL: SLP2 STANDARD

in mm

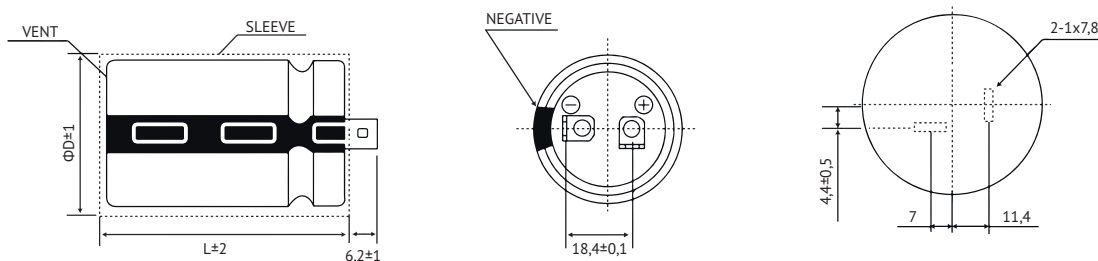

SLP2 preferred for diameter ≥ 35 .

OTHER PIN STYLES ON REQUEST.

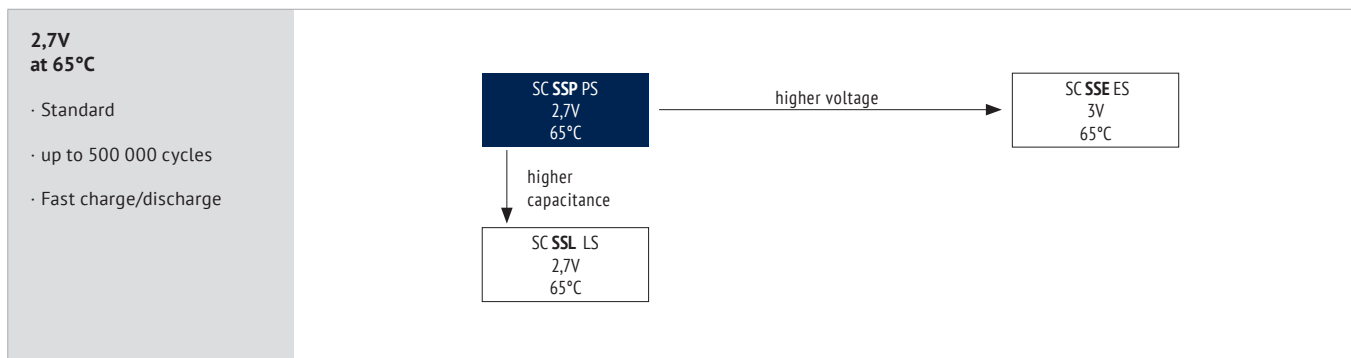

ITEM CHARACTERISTICS

Operating Temperature Range (°C)	-40 ~ +65
Rated Voltage (V)	2,7
Capacitance Range (F)	100 ~ 800
Capacitance Tolerance (25°C)	+30/-10%

! The usage at lower temperatures than indicated may be possible. Please contact the Jianghai Europe sales office for approval.

Leakage Current: After 72 hours at 25°C application of rated voltage, leakage current is not more than specified in table.

Self Discharge Voltage: After 72 hours storage at 25°C, 25~85% RH, and initial charging at U_R , the remaining voltage shall be $\geq 2,1V$

Temperature Characteristics	The specification shall be met at upper category temperature of 65°C	Capacitance Change	±10% of specified value
		ESR Change	less than specified value
	The specification shall be met at lower category temperature of -40°C	Capacitance Change	±30% of specified value
		ESR Change	less than 200% of specified value
Load Life	The specification shall be met after $\leq 2,7V$ applied at 65°C for 1 500h*	Capacitance Change	±30% of specified value
		ESR Change	less than 200% of specified value
Cycle Life	The specification shall be met after 500 000 cycles at 25°C; 1 cycle=charge-discharge from U_R to $\frac{1}{2}U_R$.	Capacitance Change	±30% of specified value
		ESR Change	less than 200% of specified value

* Load Life (constant voltage) is only allowed between 2,7V and 2,0V at $T_{surface} \leq 65°C$

ENVIRONMENTAL

The products are RoHS, WEEE and REACH compliant. The detailed version please see separate "Environmental Certificates" document or www.jianghai-europe.com

Please contact Jianghai Europe Electronic Components GmbH to request the availability of the components..

EDLC · SNAP-IN



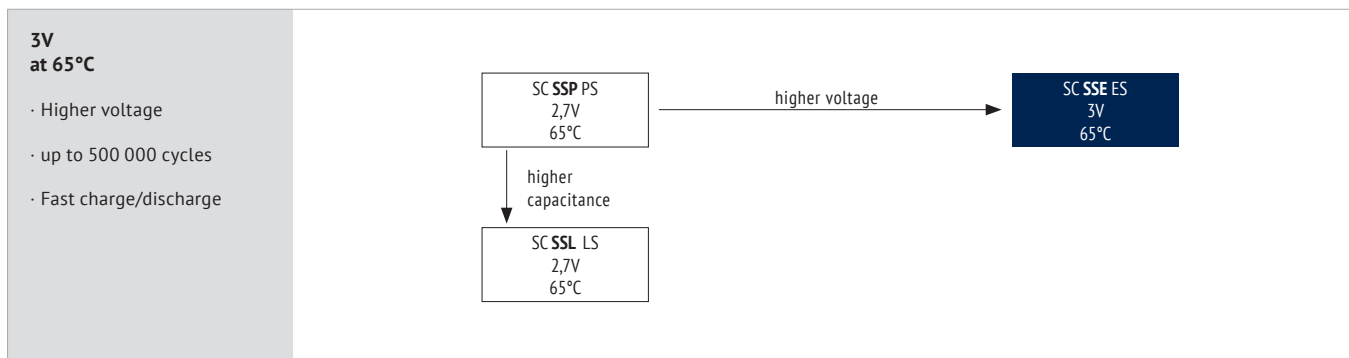

ITEM	CHARACTERISTICS
------	-----------------

Operating Temperature Range (°C)	-40 ~ +65
Rated Voltage (V)	3,0
Capacitance Range (F)	100 - 600
Capacitance Tolerance (25°C)	+30/-10%

! The usage at lower temperatures than indicated may be possible. Please contact the Jianghai Europe sales office for approval.

Leakage Current	After 72 hours at 25°C application of rated voltage, leakage current is not more than specified in table.
-----------------	---

Self Discharge Voltage	After 72 hours storage at 25°C, 25-85% RH, and initial charging at U_R , the remaining voltage shall be $\geq 2,3V$
------------------------	---

Temperature Characteristics	The specification shall be met at upper category temperature of 65°C	Capacitance Change	±10% of specified value
		ESR Change	less than specified value
	The specification shall be met at lower category temperature of -40°C	Capacitance Change	±30% of specified value
		ESR Change	less than 200% of specified value
Load Life	The specification shall be met after $\leq 3,0V$ applied at 65°C for 1 000h*	Capacitance Change	±30% of specified value
		ESR Change	less than 200% of specified value
Cycle Life	The specification shall be met after 500 000 cycles at 25°C; 1 cycle=charge-discharge from U_R to $\frac{1}{2}U_R$.	Capacitance Change	±30% of specified value
		ESR Change	less than 200% of specified value

* Load Life (constant voltage) is only allowed between 3,0V and 2,0V at $T_{surface} \leq 65^\circ C$

ENVIRONMENTAL

The products are RoHS, WEEE and REACH compliant. The detailed version please see separate "Environmental Certificates" document or www.jianghai-europe.com

Please contact Jianghai Europe Electronic Components GmbH to request the availability of the components..

EDLC · SNAP-IN



2,7V at 65°C

- Higher capacitance
- up to 500 000 cycles
- Fast charge/discharge

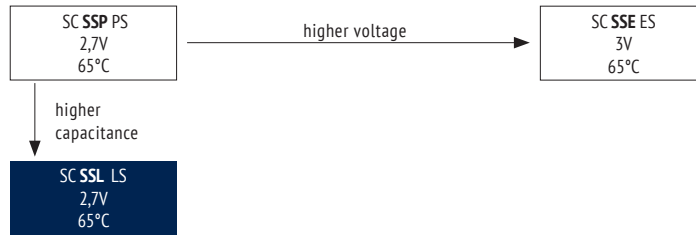

ITEM CHARACTERISTICS

Operating Temperature Range (°C)	-40 ~ +65
Rated Voltage (V)	2,7
Capacitance Range (F)	350 ~ 1200
Capacitance Tolerance (25°C)	+30/-10%

! The usage at lower temperatures than indicated may be possible. Please contact the Jianghai Europe sales office for approval.

Leakage Current	After 72 hours at 25°C application of rated voltage, leakage current is not more than specified in table.
-----------------	---

Self Discharge Voltage	After 72 hours storage at 25°C, 25~85% RH, and initial charging at U_R , the remaining voltage shall be $\geq 2,1V$
------------------------	---

Temperature Characteristics	The specification shall be met at upper category temperature of 65°C	Capacitance Change	$\pm 10\%$ of specified value
		ESR Change	less than specified value
	The specification shall be met at lower category temperature of -40°C	Capacitance Change	$\pm 30\%$ of specified value
		ESR Change	less than 200% of specified value
Load Life	The specification shall be met after $\leq 2,7V$ applied at 65°C for 1 500h	Capacitance Change	$\pm 30\%$ of specified value
		ESR Change	less than 200% of specified value
Cycle Life	The specification shall be met after 500 000 cycles at 25°C; 1 cycle=charge-discharge from U_R to $\frac{1}{2}U_R$.	Capacitance Change	$\pm 30\%$ of specified value
		ESR Change	less than 200% of specified value

* Load Life (constant voltage) is only allowed between 2,7V and 2,0V at $T_{surface} \leq 65°C$

ENVIRONMENTAL

The products are RoHS, WEEE and REACH compliant. The detailed version please see separate "Environmental Certificates" document or www.jianghai-europe.com

Please contact Jianghai Europe Electronic Components GmbH to request the availability of the components..

EDLC · SNAP-IN





3,0V at 60°C · Higher current · up to 1 000 000 cycles · Fast charge/discharge	SC SSL-J LS 3V 60°C
--	--

ITEM	CHARACTERISTICS
------	-----------------

Operating Temperature Range (°C)	-40 ~ +60 (-40 ~ +65 at 2,9V)
Rated Voltage (V)	3,0
Capacitance Range (F)	270
Capacitance Tolerance (25°C)	+30/-10%

! The usage at lower temperatures than indicated may be possible. Please contact the Jianghai Europe sales office for approval.

Leakage Current	After 72 hours at 25°C application of rated voltage, leakage current is not more than specified in table.
-----------------	---

Self Discharge Voltage	After 72 hours storage at 25°C, 25-85% RH, and initial charging at U_R , the remaining voltage shall be $\geq 2,3V$
------------------------	---

Temperature Characteristics	The specification shall be met at upper category temperature of 65°C	Capacitance Change	±10% of specified value
		ESR Change	less than specified value
	The specification shall be met at lower category temperature of -40°C	Capacitance Change	±30% of specified value
		ESR Change	less than 200% of specified value

Load Life (1)	The specification shall be met after $\leq 3,0V$ applied at 60°C for 1 500h ^{*1}	Capacitance Change	±30% of specified value
		ESR Change	less than 200% of specified value

Load Life (2)	The specification shall be met after $\leq 2,9V$ applied at 65°C for 1 500h ^{*2}	Capacitance Change	±30% of specified value
		ESR Change	less than 200% of specified value

Cycle Life	The specification shall be met after 1 000 000 cycles at 25°C; 1 cycle=charge-discharge from U_R to $\frac{1}{2}U_R$.	Capacitance Change	±30% of specified value
		ESR Change	less than 200% of specified value

*1 Load Life (constant voltage) is only allowed between 3,0V and 2,0V at $T_{surface} \leq 60°C$

*2 Load Life (constant voltage) is only allowed between 2,9V and 2,0V at $T_{surface} \leq 65°C$

DIMENSIONS ONLY FOR HGA GA (TYPE A)

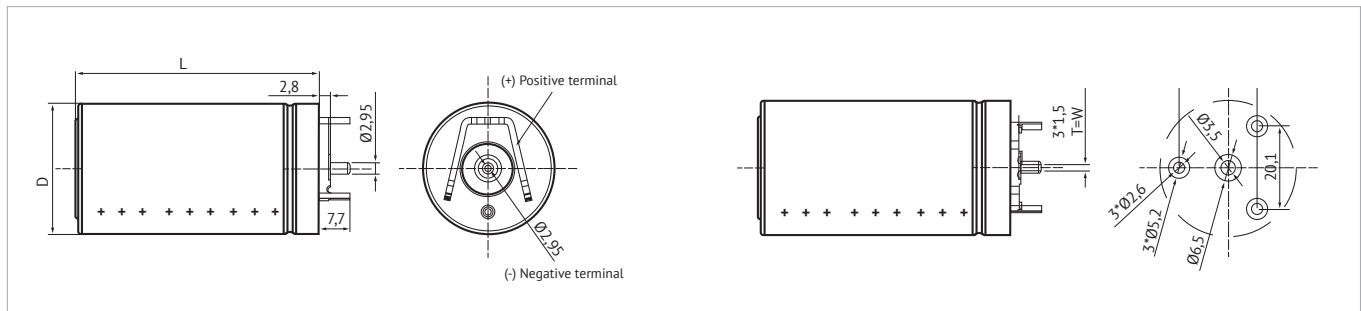

ENVIRONMENTAL

The products are RoHS, WEEE and RECh compliant. The detailed version please see separate "Environmental Certificates" document or www.jianghai-europe.com

Please contact Jianghai Europe Electronic Components GmbH to request the availability of the components..

EDLC · WELDED COLUMN



ORDER CODE AXIAL

SC	C	D	PG	2R7	308	Q	GA	610	138	E	E3	JExxxxx
Technology	Design code	Energy-Capacitor Type	Series Code	Rated Voltage Code	Capacitance Code (in F)	Capacitance Tolerance Code	Terminal style	Diameter	Length	Material Code Sleeve	for internal use	For Specials only
SC=Energy-Capacitor	Cell/Cylindric C	EDLC D	SGP PG SGE EG	2,7 2R7 3 3R0	650 657 1200 128 1500 158 1650 168 3000 308 3400 348	+30%/-10% Q +20%/-20% M +20%/-0% R	M14 welding terminal GB	61mm 610	51,5mm 052 74mm 074 85mm 085 102mm 102 138mm 138	PET E PVC Y	E E3	

TECHNICAL SPECIFICATIONS AXIAL

GB-TYPE

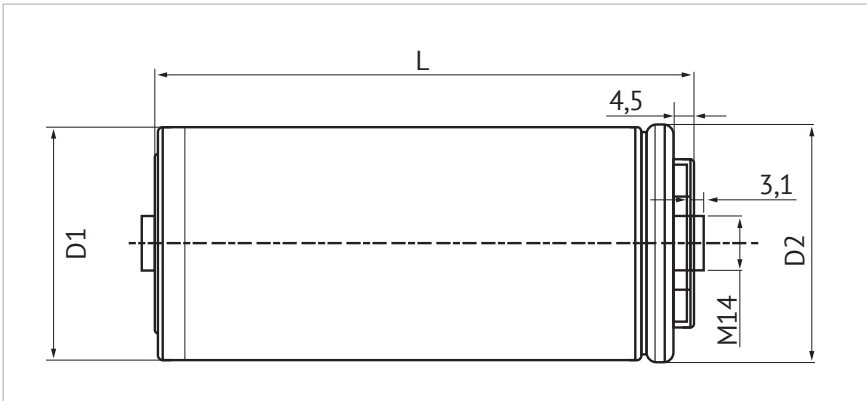

ITEMS	CRITERIA
D1	60±1mm
D2	61±1mm
L	51,5 / 74 / 85 / 102 / 138 (±2mm)

OTHER TYPES ON REQUEST



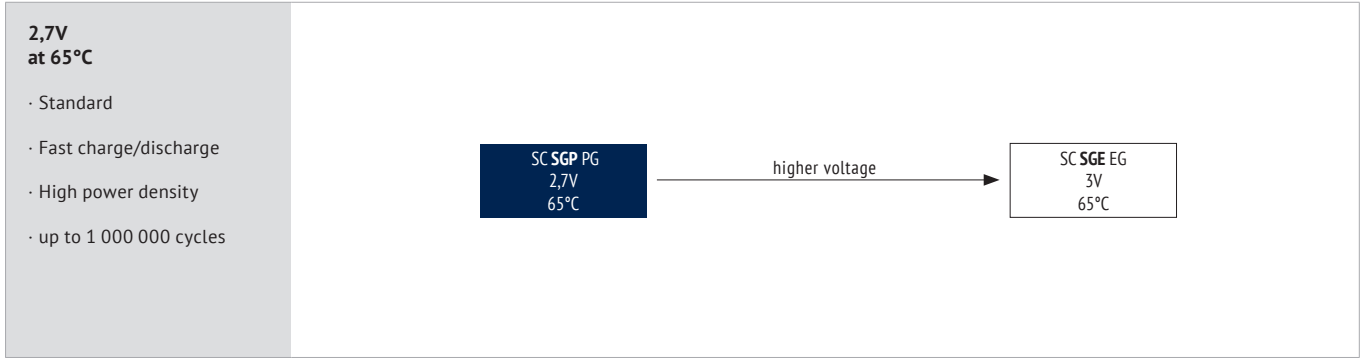

ITEM	CHARACTERISTICS
------	-----------------

Operating Temperature Range (°C)	-40 ~ +65
Rated Voltage (V)	2,7
Capacitance Range (F)	650 ~ 3 400
Capacitance Tolerance (25°C)	+20/0%

! The usage at lower temperatures than indicated may be possible. Please contact the Jianghai Europe sales office for approval.

Leakage Current	After 72 hours at 25°C application of rated voltage, leakage current is not more than specified in table.
-----------------	---

Self Discharge Voltage	After 72 hours storage at 25°C, 25-85% RH, and initial charging at U_R , the remaining voltage shall be $\geq 2,1V$
------------------------	---

Temperature Characteristics	The specification shall be met at upper category temperature of 65°C	Capacitance Change	±10% of specified value
		ESR Change	less than specified value
	The specification shall be met at lower category temperature of -40°C	Capacitance Change	±20% of specified value
		ESR Change	less than 200% of specified value

Load Life	The specification shall be met after $\leq 2,7V$ applied at 65°C for 1 500h*	Capacitance Change	±20% of specified value
		ESR Change	less than 200% of specified value

Cycle Life	The specification shall be met after 1 000 000 cycles at 25°C; 1 cycle=charge-discharge from U_R to $\frac{1}{2}U_R$.	Capacitance Change	±20% of specified value
		ESR Change	less than 200% of specified value

* Load Life (constant voltage) is only allowed between 2,7V and 2,0V at $T_{surface} \leq 65^\circ C$

ENVIRONMENTAL

The products are RoHS, WEEE and REACh compliant. The detailed version please see separate "Environmental Certificates" document or www.jianghai-europe.com

SPECIFICATIONS

U _R	C _R	ESR _{DC,max}	I _{leak}	I _R *	I _{MAX}	I _{MAX}	I _S	Size	Order Code
Rated Voltage Code	Rated Capacitance	Equivalent Series Resistance 25°C	Leakage Current 25°C (72h)	Rated Current	Max. Continuous Current ΔT15°C	Max. Continuous Current ΔT40°C	Surge Current <1sec		Details: Page 40
(V)	(F)	(mΩ)	(μA)	(A)	(A)	(A)	(A)	mm D x L	
2,7 2R7	650	0,57	1 500	19,5	54	88	640,28	61 x 51,5	SCCDPG2R7657RGB610052EE3
	1 200	0,3	4 000	36	95	155	1191,18	61 x 74	SCCDPG2R7128RGB610074EE3
	1 500	0,28	5 000	45	84	140	1426,06	61 x 85	SCCDPG2R7158RGB610085EE3
	2 000	0,25	6 000	60	126	206	1800,00	61 x 102	SCCDPG2R7208RGB610102EE3
	3 000	0,23	7 000	90	130	210	2396,45	61 x 138	SCCDPG2R7308RGB610138EE3
	3 400	0,2	8 000	102	140	225	2732,14	61 x 138	SCCDPG2R7348RGB610138EE3

■ = preferred

* Rated current I_R = 40 * I_a = 40 * C_R * U_R / 3600 (IEC 62391-1)

ENERGY STORAGE

U _R	C _R	E	Weight	Specific Energy Density	Power Density (IPM)	Order Code
Rated Voltage Code	Rated Capacitance	Stored Energy				Details: Page 40
(V)	(F)	(Wh)	(g)	(Wh/kg)	(kW/kg)	
2,7 2R7	650	0,658	180	3,66	17,76	SCCDPG2R7657RGB610052EE3
	1 200	1,215	262	4,64	23,19	SCCDPG2R7128RGB610074EE3
	1 500	1,519	300	5,06	21,70	SCCDPG2R7158RGB610085EE3
	2 000	2,025	380	5,33	19,18	SCCDPG2R7208RGB610102EE3
	3 000	3,038	500	6,08	15,85	SCCDPG2R7308RGB610138EE3
	3 400	3,443	510	6,75	17,87	SCCDPG2R7348RGB610138EE3

■ = preferred

3V at 65°C · Higher voltage · Fast charge/discharge · High power density · up to 1 000 000 cycles	<div style="border: 1px solid black; display: inline-block; padding: 5px;"> SC SGP PG 2,7V 65°C </div> → higher voltage → <div style="background-color: #003366; color: white; padding: 5px; display: inline-block;"> SC SGE EG 3V 65°C </div>
--	---

ITEM	CHARACTERISTICS
------	-----------------

Operating Temperature Range (°C)	-40 ~ +65
Rated Voltage (V)	3,0
Capacitance Range (F)	650 ~ 3400
Capacitance Tolerance (25°C)	+20/-0%

The usage at lower temperatures than indicated may be possible. Please contact the Jianghai Europe sales office for approval.

Leakage Current	After 72 hours at 25°C application of rated voltage, leakage current is not more than specified in table.
-----------------	---

Self Discharge Voltage	After 72 hours storage at 25°C, 25-85% RH, and initial charging at U_R , the remaining voltage shall be $\geq 2,3V$
------------------------	---

Temperature Characteristics	The specification shall be met at upper category temperature of 65°C	Capacitance Change	±10% of specified value
		ESR Change	less than specified value
	The specification shall be met at lower category temperature of -40°C	Capacitance Change	±20% of specified value
		ESR Change	less than 200% of specified value

Load Life	The specification shall be met after $\leq 3,0V$ applied at 65°C for 1 500h*	Capacitance Change	±20% of specified value
		ESR Change	less than 200% of specified value

Cycle Life	The specification shall be met after 1 000 000 cycles at 25°C; 1 cycle=charge-discharge from U_R to $\frac{1}{2}U_R$.	Capacitance Change	±20% of specified value
		ESR Change	less than 200% of specified value

* Load Life (constant voltage) is only allowed between 3,0V and 2,0V at $T_{surface} \leq 65^\circ C$

ENVIRONMENTAL

The products are RoHS, WEEE and REACH compliant. The detailed version please see separate "Environmental Certificates" document or www.jianghai-europe.com

SPECIFICATIONS

U_R	C_R	$ESR_{DC,max}$	I_{leak}	I_R^*	I_{MAX}	I_{MAX}	I_S	Size	Order Code
Rated Voltage Code	Rated Capacitance	Equivalent Series Resistance 25°C	Leakage Current 25°C (72h)	Rated Current	Max. Continuous Current $\Delta T 15^\circ C$	Max. Continuous Current $\Delta T 40^\circ C$	Surge Current <1sec		Details: Page 40
(V)	(F)	(mΩ)	(μA)	(A)	(A)	(A)	(A)	mm D x L	
3 3R0	650	0,57	3 000	21,7	54	88	711,42	61 x 51,5	SCCDEG3R0657RGB610052EE3
	1 200	0,3	4 000	40,0	95	155	1323,53	61 x 74	SCCDEG3R0128RGB610074EE3
	1 500	0,28	6 000	50,0	84	140	1584,51	61 x 85	SCCDEG3R0158RGB610085EE3
	1 650	0,2	6 000	55,0	84	140	1860,90	61 x 85	SCCDEG3R0168RGB610085EE3
	2 000	0,27	8 000	66,7	126	206	1948,05	61 x 102	SCCDEG3R0208RGB610102EE3
	3 000	0,23	7 000	100,0	130	210	2662,72	61 x 138	SCCDEG3R0308RGB610138EE3
	3 400	0,2	8 000	113,3	140	225	3035,71	61 x 138	SCCDEG3R0348RGB610138EE3

■ = preferred

* Rated current $I_R = 40^\circ C_R = 40^\circ C_R \cdot U_R / 3600$ (IEC 62391-1)

ENERGY STORAGE

U_R	C_R	E	Weight	Specific Energy Density	Power Density (IPM)	Order Code
Rated Voltage Code	Rated Capacitance	Stored Energy				Details: Page 40
(V)	(F)	(Wh)	(g)	(Wh/kg)	(kW/kg)	
3 3R0	650	0,813	180	4,51	21,93	SCCDEG3R0657RGB610052EE3
	1 200	1,500	262	5,73	28,63	SCCDEG3R0128RGB610074EE3
	1 500	1,875	315	5,95	25,51	SCCDEG3R0158RGB610085EE3
	1 650	2,063	318	6,49	35,38	SCCDEG3R0168RGB610085EE3
	2 000	2,500	380	6,58	21,93	SCCDEG3R0208RGB610102EE3
	3 000	3,750	500	7,50	19,57	SCCDEG3R0308RGB610138EE3
	3 400	4,250	510	8,33	22,06	SCCDEG3R0348RGB610138EE3

■ = preferred

RADIAL TYPE

LiC: Order Code RADIAL **46**

LiC: Technical Specifications RADIAL **46**

SERIES	CODE	TYPE	TEMPERATURE RANGE	CYCLES	INFO	
SC HBR	BR	RADIAL	-15 ~ +70°C	up to 500 000	Standard	47
SC HBRL	BL	RADIAL	-25 ~ +70°C	up to 250 000	Wider Temperature Range	49
SC HBE	BE	RADIAL	-25 ~ +70°C	up to 250 000	Highest Capacitance	51

AXIAL/WELDED COLUMN TYPE

SERIES	CODE	TYPE	TEMPERATURE RANGE	CYCLES	INFO	
SC HGA	GA	AXIAL	-25 ~ +65°C	50 000	High Power Density	53

POUCH TYPE

LiC: Order Code POUCH **55**

LiC: Technical Specifications POUCH **55**

SERIES	CODE	TYPE	TEMPERATURE RANGE	CYCLES	INFO	
SC HAA	AA	POUCH	-25 ~ +55°C	50 000	Standard	56
SC HAE	AE	POUCH	-25 ~ +55°C	50 000	Highest Capacitance	58



ORDER CODE LiC RADIAL

SC	M	D	BE	3R8	504	Q	LL	35	1860	PET	E3	JExxxxx
Technology	Design Type	Energy-Capacitor Type	Series Code	Rated Voltage Code	Capacitance Code (in F)	Capacitance Tolerance Code	Lead Form Code	Pitch	Dimension $\varnothing D \times h$	Material Code Sleeve	for internal use	for Specials only
SC = Energy-Capacitor	Single Cell C	LI-C H	HBE BE HBR BR HBRL BL	3,8 3R8	30 306 50 506 55 556 70 706 85 856 110 117 150 157	+30% / -10% Q +20% / -20% M	Long Leads LL other style on request	3,5mm 35 5,0mm 50 7,5mm 75	8x25 0825 10x16 1016 10x20 1020 10x25 1025 10x30 1030	PET E PVC V	E3	

LiC · RADIAL

TECHNICAL SPECIFICATIONS LiC RADIAL

DIMENSIONS FOR LOOSE, LONG-LEAD TYPE (BULK)

· ORDER CODE: LL

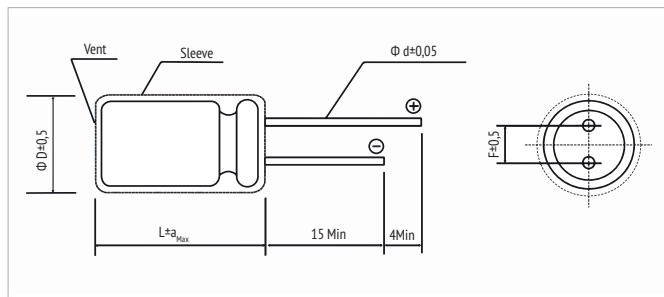

$\varnothing D$	5	6,3	8	10	12,5	16	18
F	2,0	2,5	3,5	5,0	7,5		
$\varnothing d$	0,5			0,6		0,8	
a_{Max}	2,0						

in mm

OTHER LEAD TYPES ON REQUEST



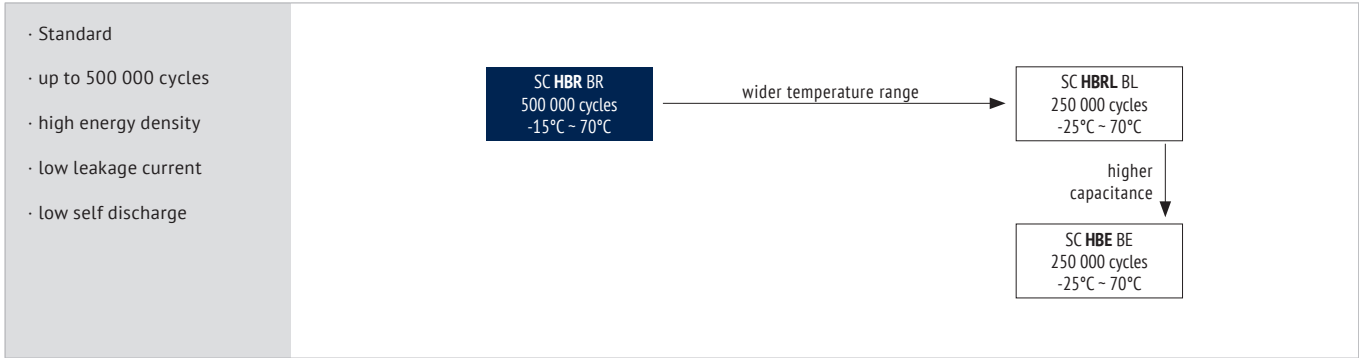

ITEM	CHARACTERISTICS
------	-----------------

Operating Temperature Range (°C)	-15 ~ +70 (85°C at 3,5V)
Voltage Range (V)	3,8 - 2,5
Min. allowed Operating Voltage (V)	2,2
Capacitance Range (F)	30 - 50
Capacitance Tolerance (25°C)	±20%

! The usage at lower temperatures than indicated may be possible. Please contact the Jianghai Europe sales office for approval.

Leakage Current	After 72 hours at 25°C application of rated voltage, leakage current is not more than specified in table.
-----------------	---

Self Discharge Current	After initial charging at U_R and 3 months of storage at 25°C, 25-85% RH, leakage current is not more than specified in table.
------------------------	--

Self Discharge Voltage	After 72 hours storage at 25°C, 25-85% RH, and initial charging at U_R , the remaining voltage shall be $\geq 3,7$ V.
------------------------	---

Temperature Characteristics	The specification shall be met at upper category temperature of 70°C	Capacitance Change	±10% of initial value
		ESR Change	less than specified value
	The specification shall be met at lower category temperature of -15°C	Capacitance Change	±50% of initial value
		ESR Change	less than 1 000% of specified value

Load Life	The specification shall be met after rated voltage applied at 70°C for 1 000h	Capacitance Change	±30% of initial value
		ESR Change	less than 200% of specified value

Cycle Life	The specification shall be met after 500 000 cycles at 25°C; 1 cycle=charge-discharge from 3,8V to 2,5V	Capacitance Change	±30% of initial value
		ESR Change	less than 200% of specified value

ENVIRONMENTAL
The products are RoHS, WEEE and REACH compliant. The detailed version please see separate "Environmental Certificates" document or www.jianghai-europe.com

! SAFETY NOTE
Never discharge below 2,2V or short-circuit. See instructions for soldering at page 8.

LIC · RADIAL



LIC · RADIAL

SPECIFICATIONS

U _R	C _R	ESR _{DC,max}	ESR _{AC,max}	I _{leak}	I _r	I _{MAX}	I _s	Size	Order Code
Rated Voltage Code	Rated Capacitance	Equivalent Series Resistance 25°C	Equivalent Series Resistance 25°C 1kHz	Leakage Current 25°C (72h)	Rated Current	Max. Continuous Current ΔT15°C rise	Surge Current <3sec		Details: Page 46
(V)	(F)	(mΩ)	(mΩ)	(μA)	(A)	(A)	(A)	mm DxL	
3,8 3R8	30	900	250	3	0,15	0,7	0,9	8 x 25	SCCHBR3R8306MLL350825EE3
		900	250	3	0,15	0,7	1	10 x 16	SCCHBR3R8306MLL501026EE3
	50	700	200	4,5	0,25	1,3	1,8	10 x 20	SCCHBR3R8506MLL501020EE3

ENERGY STORAGE

U _R	C _R	E	Specific Energy Density	Specific Power Density	Weight	Order Code
Rated Voltage Code	Rated Capacitance	Stored Energy				Details: Page 46
(V)	(F)	(Wh)	(Wh/kg)	(kW/kg)	(g)	
3,8 3R8	30	0,034	15,51	1,82	2,2	SCCHBR3R8306MLL350825EE3
		0,034	13,65	1,60	2,5	SCCHBR3R8306MLL501026EE3
	50	0,057	17,77	1,61	3,2	SCCHBR3R8506MLL501020EE3



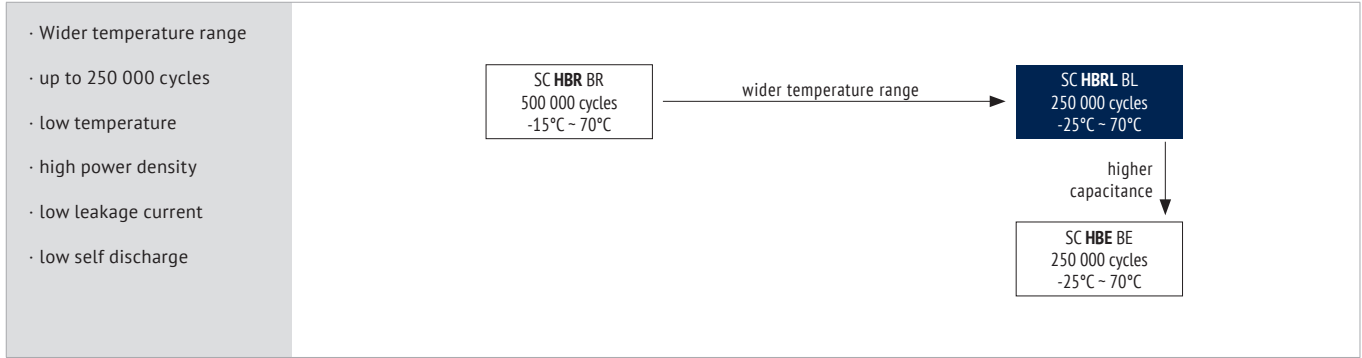

ITEM	CHARACTERISTICS
------	-----------------

Operating Temperature Range (°C)	-25 ~ +70
Voltage Range (V)	3,8 ~ 2,5
Min. allowed Operating Voltage (V)	2,2
Capacitance Range (F)	30 ~ 70
Capacitance Tolerance (25°C)	±20%

! The usage at lower temperatures than indicated may be possible. Please contact the Jianghai Europe sales office for approval.

Leakage Current	After 72 hours at 25°C application of rated voltage, leakage current is not more than specified in table.
-----------------	---

Self Discharge Current	After initial charging at U_R and 3 months of storage at 25°C, 25-85% RH, leakage current is not more than specified in table.
------------------------	--

Self Discharge Voltage	After 72 hours storage at 25°C, 25-85% RH, and initial charging at U_R , the remaining voltage shall be $\geq 3,7$ V.
------------------------	---

Temperature Characteristics	The specification shall be met at upper category temperature of 70°C	Capacitance Change	±10% of initial value
		ESR Change	less than specified value
	The specification shall be met at lower category temperature of -25°C	Capacitance Change	±50% of initial value
		ESR Change	less than 1 000% of specified value

Load Life	The specification shall be met after rated voltage applied at 70°C for 1 000h	Capacitance Change	±30% of initial value
		ESR Change	less than 200% of specified value

Cycle Life	The specification shall be met after 250 000 cycles at 25°C; 1 cycle=charge-discharge from 3,8V to 2,5V	Capacitance Change	±30% of initial value
		ESR Change	less than 200% of specified value

ENVIRONMENTAL
The products are RoHS, WEEE and REACH compliant. The detailed version please see separate "Environmental Certificates" document or www.jianghai-europe.com

! SAFETY NOTE
Never discharge below 2,2V or short-circuit. See instructions for soldering at page 8.

LIC · RADIAL



SPECIFICATIONS

U _R	C _R	ESR _{DC,max}	ESR _{AC,max}	I _{leak}	I _R	I _{MAX}	I _S	Size	Order Code
Rated Voltage Code	Rated Capacitance	Equivalent Series Resistance 25°C	Equivalent Series Resistance 25°C 1kHz	Leakage Current 25°C (72h)	Rated Current	Max. Continuous Current ΔT15°C rise	Surge Current <3sec		
(V)	(F)	(mΩ)	(mΩ)	(μA)	(A)	(A)	(A)	mm DxL	Details: Page 46
3,8 3R8	30	700	250	4	0,15	0,7	0,9	8 x 25	SCCHBL3R8306MLL350825EE3
		550	250	4	0,15	0,7	1	10 x 16	SCCHBL3R8306MLL501016EE3
	50	450	200	6	0,25	1,4	1,8	10 x 20	SCCHBL3R8506MLL501020EE3
	70	250	100	8	0,35	1,8	3	10 x 25	SCCHBL3R8706MLL501025EE3

ENERGY STORAGE

U _R	C _R	E	Specific Energy Density	Specific Power Density	Weight	Order Code
Rated Voltage Code	Rated Capacitance	Stored Energy				
(V)	(F)	(Wh)	(Wh/kg)	(kW/kg)	(g)	Details: Page 46
3,8 3R8	30	0,034	15,51	2,34	2,2	SCCHBL3R8306MLL350825EE3
		0,034	13,65	2,63	2,5	SCCHBL3R8306MLL501016EE3
	50	0,057	17,77	2,51	3,2	SCCHBL3R8506MLL501020EE3
	70	0,080	20,95	3,80	3,8	SCCHBL3R8706MLL501025EE3

LIC · RADIAL



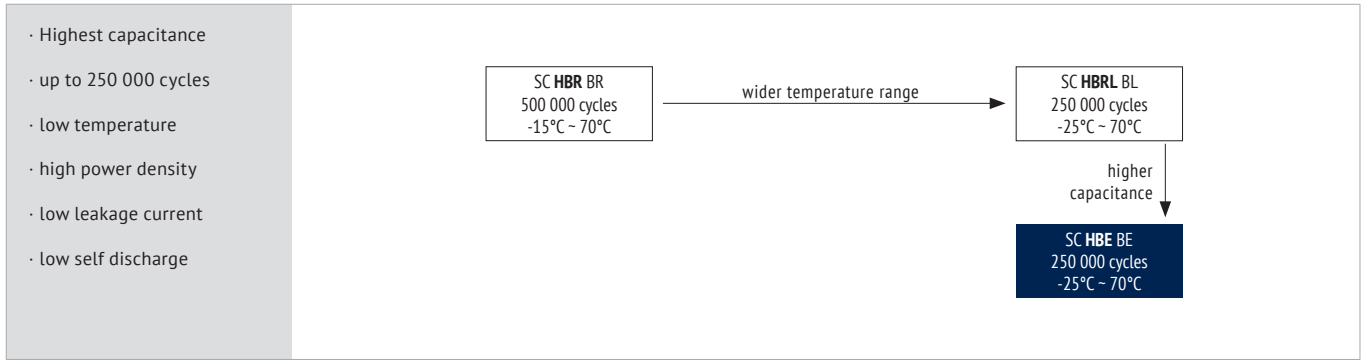

ITEM	CHARACTERISTICS
------	-----------------

Operating Temperature Range (°C)	-25 ~ +70
Voltage Range (V)	3,8 ~ 2,5
Min. allowed Operating Voltage (V)	2,2
Capacitance Range (F)	55 ~ 150
Capacitance Tolerance (25°C)	±20%

! The usage at lower temperatures than indicated may be possible. Please contact the Jianghai Europe sales office for approval.

Leakage Current	After 72 hours at 25°C application of rated voltage, leakage current is not more than specified in table.
-----------------	---

Self Discharge Current	After initial charging at U_R and 3 months of storage at 25°C, 25-85% RH, leakage current is not more than specified in table.
------------------------	--

Self Discharge Voltage	After 72 hours storage at 25°C, 25-85% RH, and initial charging at U_R , the remaining voltage shall be $\geq 3,7$ V.
------------------------	---

Temperature Characteristics	The specification shall be met at upper category temperature of 70°C	Capacitance Change	±10% of initial value
		ESR Change	less than specified value
	The specification shall be met at lower category temperature of -25°C	Capacitance Change	±50% of initial value
		ESR Change	less than 1 000% of specified value

Load Life	The specification shall be met after rated voltage applied at 70°C for 1 000h	Capacitance Change	±30% of initial value
		ESR Change	less than 200% of specified value

Cycle Life	The specification shall be met after 250 000 cycles at 25°C; 1 cycle=charge-discharge from 3,8V to 2,5V	Capacitance Change	±30% of initial value
		ESR Change	less than 200% of specified value

ENVIRONMENTAL
The products are RoHS, WEEE and REACH compliant. The detailed version please see separate "Environmental Certificates" document or www.jianghai-europe.com

! SAFETY NOTE
Never discharge below 2,2V or short-circuit. See instructions for soldering at page 8.

LIC · RADIAL



SPECIFICATIONS

U _R	C _R	ESR _{DC,max}	ESR _{AC,max}	I _{leak}	I _R	I _{MAX}	I _S	Size	Order Code
Rated Voltage Code	Rated Capacitance	Equivalent Series Resistance 25°C	Equivalent Series Resistance 25°C 1kHz	Leakage Current 25°C (72h)	Rated Current	Max. Continuous Current ΔT15°C	Surge Current <3sec		
(V)	(F)	(mΩ)	(mΩ)	(μA)	(A)	(A)	(A)	mm DxL	Details: Page 46
3,8 3R8	55	450	200	5	0,275	1,7	1,8	8 x 25	SCCHBE3R8556MLL350825EE3
						1,8		10 x 16	SCCHBE3R8556MLL501016EE3
	85	250	120	8	0,425	2,1	3,5	10 x 20	SCCHBE3R8856MLL501020EE3
	110	220	90	9	0,55	2,3	4	10 x 25	SCCHBE3R8117MLL501025EE3
	150	140	70	15	0,75	2,3	6	10 x 30	SCCHBE3R8157MLL501030EE3

ENERGY STORAGE

U _R	C _R	E	Specific Energy Density	Specific Power Density	Weight	Order Code
Rated Voltage Code	Rated Capacitance	Stored Energy				
(V)	(F)	(Wh)	(Wh/kg)	(kW/kg)	(g)	Details: Page 46
3,8 3R8	55	0,063	28,44	3,65	2,2	SCCHBE3R8556MLL350825EE3
			25,03	3,21	2,5	SCCHBE3R8556MLL501016EE3
	85	0,097	30,21	4,51	3,2	SCCHBE3R8856MLL501020EE3
	110	0,125	32,93	4,32	3,8	SCCHBE3R8117MLL501025EE3
	150	0,171	34,13	5,16	5	SCCHBE3R8157MLL501030EE3

LIC · RADIAL





- High power density
- High energy density
- Welded column terminal
- New improved cell design



ITEM CHARACTERISTICS

Operating Temperature Range (°C)	-25 - +65
Voltage Range (V)	2,5 - 4,0
Min. allowed Operating Voltage (V)	2,0
Capacitance Range (F)	3 000 - 25 000
Capacitance Tolerance (25°C)	±20%

! The usage at lower temperatures than indicated may be possible. Please contact the Jianghai Europe sales office for approval.

Leakage Current After 72 hours at 25°C application of rated voltage, leakage current is not more than specified in table.

Self Discharge Voltage After 72 hours storage at 25°C, 25-85% RH, and initial charging at U_R , the remaining voltage shall be $\geq 3,92V$

Temperature Characteristics	The specification shall be met at upper category temperature of 65°C	Capacitance Change	±10% of specified value
		ESR Change	less than specified value
	The specification shall be met at lower category temperature of -40°C	Capacitance Change	±50% of specified value
		ESR Change	less than 400% of specified value

Load Life	The specification shall be met after rated voltage applied at 65°C for 1 000h	Capacitance Change	±20% of specified value
		ESR Change	less than 200% of specified value

Cycle Life	The specification shall be met after 50 000 cycles at 25°C; 1 cycle=charge-discharge from 4,0V to 2,5V	Capacitance Change	±20% of specified value
		ESR Change	less than 200% of specified value

2. Cycle Life	The specification shall be met after 500 000 cycles at 25°C; 1 cycle=charge-discharge from 3,5V to 2,5V	Capacitance Change	±20% of specified value
		ESR Change	less than 200% of specified value

ENVIRONMENTAL

The products are RoHS, WEEE and REAcH compliant. The detailed version please see separate "Environmental Certificates" document or www.jianghai-europe.com

! SAFETY NOTE

Never discharge below 2,0V or short-circuit. See instructions for soldering at page 8.

LiC · AXIAL/WELDED COLUMN



DIMENSIONS ONLY FOR HGA GA (TYPE A)

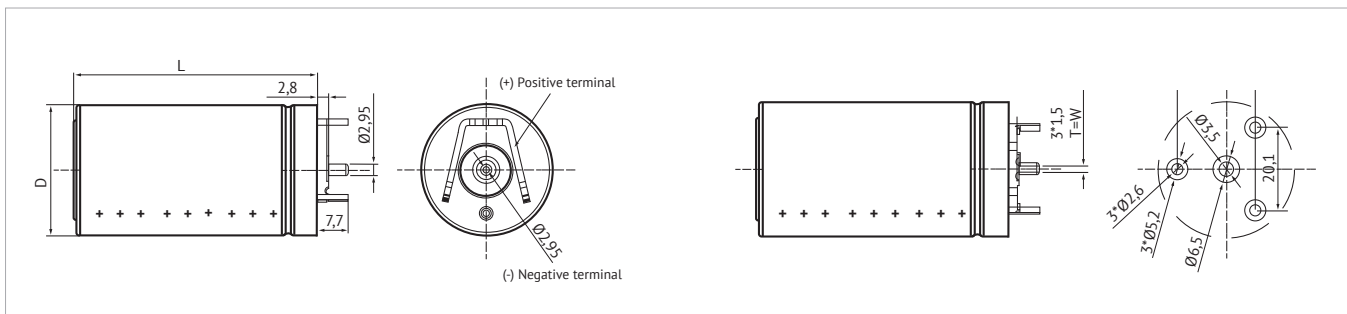

Diameter	D = 33mm ± 1mm
Length	L = 62mm ± 1mm

DIMENSIONS ONLY FOR HGA GA (TYPE B)

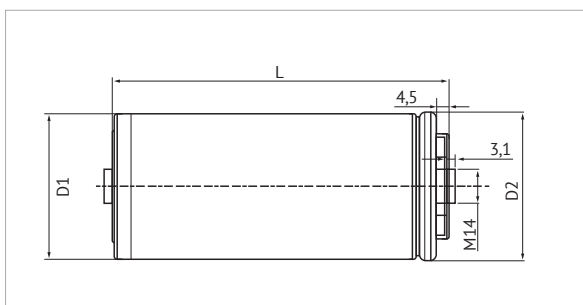

Diameter	D1 = 60±1mm D2 = 61±1mm
Length	L = 74±2mm

LiC · AXIAL/WELDED COLUMN

OTHER TERMINAL TYPES ON REQUEST

SPECIFICATIONS

U _R	C _R	ESR _{DC,max}	ESR _{AC,max}	I _R	I _{MAX}	I _S	Size	Type	Order Code
Rated Voltage Code	Rated Capacitance	Equivalent Series Resistance 25°C	Equivalent Series Resistance 25°C 1kHz	Rated Current	Max. Continuous Current ΔT15°C	Surge Current <3sec	mm DxL		
(V)	(F)	(mΩ)	(mΩ)	(A)	(A)	(A)			
4,0 4R0	3 000	3	2,5	13	30	145	33 x 62	A	SCCHGA4R0308ME3
	11 000	0,47	0,46	55	65	450	61 x 74	B	SCCHGA4R0119ME3

■ = preferred

ENERGY STORAGE

U _R	C _R	E	Energy Density	Power Density	Weight	Order Code
Rated Voltage Code	Rated Capacitance	Stored Energy	Energy Density	Power Density	Weight	
(V)	(F)	(Wh)	(Wh/kg)	(kW/kg)	(g)	
4.0 4R0	3 000	4,8	48,00	13,33	100	SCCHGA4R0308ME3
	11 000	15,5	40,26	22,11	385	SCCHGA4R0119ME3

■ = preferred



ORDER CODE LiC POUCH

SC	C	H	AA	4R0	108	M	S	15	BB055	E3	JExxxx
Technology	Design Code	Energy-Capacitor Type	Series Code	Rated Voltage Code (V)	Capacitance Code (in F)	Capacitance Tolerance Code (%)	Terminal Type	Terminal Width W_1	Dimension L x W x T	for internal use	for Specials only
SC = Energy-Capacitor	Single Cell C	Li-C H	HAA AA HAE AE	4,0 4R0	6000 608 10000 109 12000 129 16000 169 21000 219 22000 229 29000 299	+20% / -20% M	Contacts two sides (Type 1) D Contacts one side (Type 2) S	15mm 15 60mm 60	100x71x9,0 BB090 300x123x3,5 DC035 300x123x5,2 DC052 300x123x8,0 DC080 300x123x8,3 DC083	E3	

TECHNICAL SPECIFICATIONS LiC POUCH

DIMENSIONS

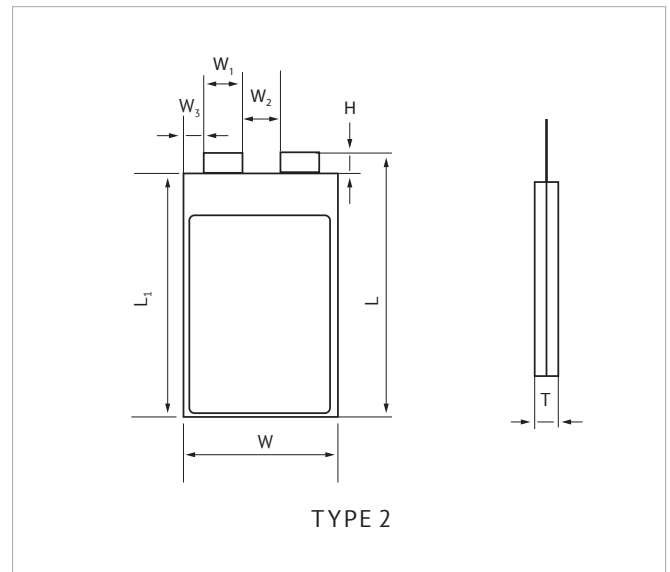
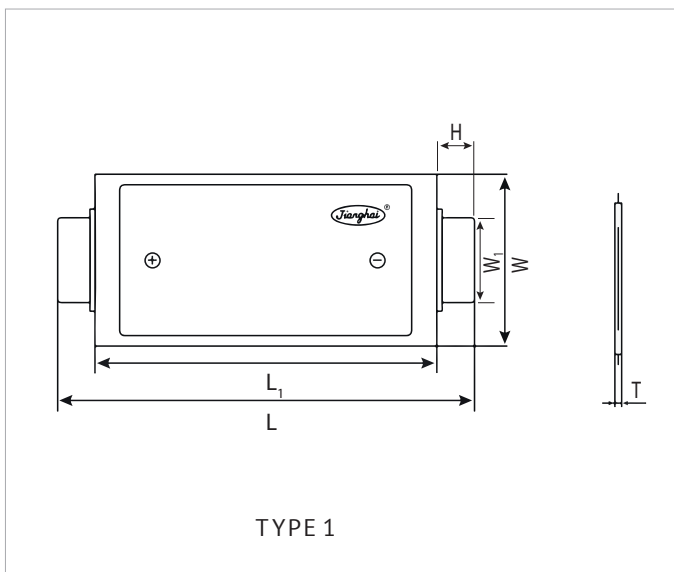

Type	L ± 5	L ₁ ± 3	W ± 3	W ₁ ± 1	W ₂ ± 1	W ₃ ± 0,5	H ± 1	T ± 0,5
Type 1	300	245	123	60	-	-	25	3,5
								5,2
								5,5
								8,0
								8,2
								8,3
Type 2	100	95	71	15	15	13	5	9,0

in mm



- Standard
- wide temperature range
- very high energy density
- low ESR

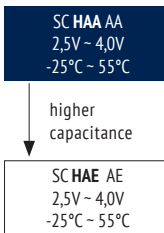

ITEM CHARACTERISTICS

Operating Temperature Range (°C)	-25 ~ +55
Voltage Range (V)	4,0 ~ 2,5
Capacitance Range (F)	6 000 ~ 16 000
Capacitance Tolerance (25°C)	±20%

! The usage at lower temperatures than indicated may be possible. Please contact the Jianghai Europe sales office for approval.

Leakage Current After 72 hours at 25°C application of rated voltage, leakage current is not more than specified in table.

Self Discharge Voltage After 72 hours storage at 25°C, 25-85% RH, and initial charging at U_R , the remaining voltage shall be $\geq 3,92$ V.

Temperature Characteristics	The specification shall be met at upper category temperature of 55°C	Capacitance Change	±10% of specified value
		ESR Change	less than specified value
Temperature Characteristics	The specification shall be met at lower category temperature of -25°C	Capacitance Change	±50% of specified value
		ESR Change	less than 400% of specified value
Load Life	The specification shall be met after rated voltage applied at 55°C for 1 000h	Capacitance Change	±20% of specified value
		ESR Change	less than 200% of specified value
Cycle Life	The specification shall be met after 50 000 cycles at 25°C; 1 cycle=charge-discharge from 4,0V to 2,5V	Capacitance Change	±20% of specified value
		ESR Change	less than 200% of specified value

ENVIRONMENTAL
The products are RoHS, WEEE and REACH compliant. The detailed version please see separate "Environmental Certificates" document or www.jianghai-europe.com

! SAFETY NOTE
Never discharge below 2,5V or short-circuit. See Handling Precautions page 6.



SPECIFICATIONS

U _R Rated Voltage Code (V)	U _{min} Min. Operating Voltage (V)	C _R Rated Capacitance (F)	ESR _{DC,max} Equivalent Series Resistance 25°C (mΩ)	ESR _{AC,max} Equivalent Series Resistance 25°C (1kHz) (mΩ)	I _{leak} Leakage Current 25°C (72h) (μA)	I _{SD} Self Discharge Current (3months) (μA)	I _R * Rated Current (A)	I _{MAX} Max. Continuous Current ΔT15°C (A)	I _S Surge Current <5sec (A)	Size (mm)			Order Code Details: Page 55
										W	L	H	
4 4R0	2,5	6 000	4,5	3	480	154	30	40	100	300	123	3,5	SCCHAA4R0608MD60DC035E3
		10 000	1,8	1,2	530	257	50	50	150	300	123	5,2	SCCHAA4R0109MD60DC055E3
		16 000	1,5	1,2	580	412	50	65	200	300	123	8,0	SCCHAA4R0169MD60DC080E3

= preferred

 * Rated current I_R = 4 * C_R * U_R / 3600 (IEC 62391-1)

ENERGY STORAGE

U _R Rated Voltage Code (V)	U _{min} Min. Operating Voltage (V)	C _R Rated Capacitance (F)	E Stored Energy (Wh)	Weight (g)	Specific Energy Density (Wh/kg)	Power Density (kW/kg)	Order Code Details: Page 55
		10 000	13,20	240	55,00	9,26	SCCHAA4R0109MD60DC055E3
		16 000	22,00	355	61,97	7,51	SCCHAA4R0169MD60DC080E3

= preferred

- Highest capacitance
- wide temperature range
- very high energy density
- low ESR

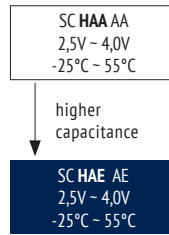

ITEM CHARACTERISTICS

Operating Temperature Range (°C)	-25 ~ +55
Voltage Range (V)	4,0 ~ 2,5
Surge Voltage (V)	4,35
Capacitance Range (F)	12 000 ~ 29 000
Capacitance Tolerance (25°C)	±20%

! The usage at lower temperatures than indicated may be possible. Please contact the Jianghai Europe sales office for approval.

Leakage Current: After 72 hours at 25°C application of rated voltage, leakage current is not more than specified in table.

Self Discharge Voltage: After 72 hours storage at 25°C, 25~85% RH, and initial charging at U_R , the remaining voltage shall be $\geq 3,92$ V.

Temperature Characteristics	The specification shall be met at upper category temperature of 55°C	Capacitance Change	±10% of specified value
		ESR Change	less than specified value
	The specification shall be met at lower category temperature of -25°C	Capacitance Change	±50% of specified value
		ESR Change	less than 400% of specified value
Load Life	The specification shall be met after rated voltage applied at 55°C for 1 000h	Capacitance Change	±20% of specified value
		ESR Change	less than 200% of specified value
Cycle Life	The specification shall be met after 50 000 cycles at 25°C; 1 cycle=charge-discharge from 4,0V to 2,5V	Capacitance Change	±20% of specified value
		ESR Change	less than 200% of specified value

ENVIRONMENTAL
The products are RoHS, WEEE and REACH compliant. The detailed version please see separate "Environmental Certificates" document or www.jianghai-europe.com

! SAFETY NOTE
Never discharge below 2,5V or short-circuit. See Handling Precautions page 6.

LiC · POUCH



SPECIFICATIONS

U _R	U _{min}	C _R	C _{TYP}	ESR _{DC,max}	ESR _{AC,max}	I _{leak}	I _{SD}	I _R *	I _{MAX}	I _S	Size			Order Code
Rated Voltage Code	Min. Operating Voltage	Rated Capacitance QC/T-741	Rated Capacitance IEC	Equivalent Series Resistance 25°C	Equivalent Series Resistance 25°C (1kHz)	Leakage Current 25°C (72h)	Self Discharge Current (3months)	Rated Current	Max. Continuous Current ΔT15°C	Surge Current <5sec				Details: Page 55
(V)	(V)	(F)	(F)	(mΩ)	(mΩ)	(μA)	(μA)	(A)	(A)	(A)	(mm)			
											L	W	T	
4 4R0	2,5	17 000	22 000	1,2	1,2	800	460	42,5	65	280	300	123	8,3	SCCHAE4R0229MD60DC083E3

* Rated current I_R = 4*I_A = 4*C_R*U_R/3600 (IEC 62391-1)

ENERGY STORAGE

U _R	U _{min}	C _R					Order Code
Rated Voltage Code	Min. Operating Voltage	Rated Capacitance QC/T-741	Weight	Storage Energy	Specific Energy Density	Power Density	Details: Page 55
(V)	(V)	(F)	(g)	(Wh)	(Wh/kg)	(kW/kg)	
4 4R0	2,5	17 000	380	34	89,47	8,77	SCCHAE4R0229MD60DC083E3



DIMENSIONS

CUSTOMER SPECIFIC ON REQUEST

ENERGY DENSITY & POWER DENSITY

EVERY MODUL IS DESIGNED ACCORDING TO CUSTOMERS REQUIREMENTS

ELECTRONICAL CELL MANAGEMENT SYSTEM (CMS)

JIANGHAI PROVIDES MODULES CONTAINING AN ELECTRONICAL CHARGE/DISCHARGE CONTROL UNIT INCLUDING BALANCING AND CELL MANAGEMENT SYSTEMS INSIDE

VOLTAGE & CAPACITY RANGE

CUSTOMER SPECIFIC ON REQUEST

NUMBERS OF CYCLES

UP TO 1 000 000 CHARGE-DISCHARGE CYCLES



ALL ADVANTAGES AT A GLANCE

 HIGH ENERGY DENSITY	 HIGH POWER DENSITY	 WIDE VOLTAGE RANGE	 MANY CHARGE/DISCHARGE CYCLES	 LOW LEAKAGE CURRENT	 HIGH SAFETY! NO EXPLODING OR BURNING!
--------------------------------	-------------------------------	-------------------------------	---	--------------------------------	--

ASSISTANCE IN MAKING THE RIGHT CHOICE

Most of the modules are customized and tailored to a specific application. We need your requirements so that we can find and build the right energy storage for you. The questions below should help you to gather all the information together.

Which maximum voltage do you need and up to which voltage does your circuit work?

Voltage range:

How much power do you need and how long is this energy needed?

Capacitance or energy:

Time:

In what temperature range does the module have to work?

Temperature range:

Which lifespan and / or no. of cycles should the energy storage, provide energy?

Lifetime:

Number of cycles:

How much space is available?

Dimensions:

**Any questions?
Please contact:**

	JIANGHAI EUROPE Electronic Components GmbH Uerdinger Straße 95 47799 Krefeld (Germany) T: +49 (0) 21 51 / 65 20 88 - 63 M: +49 (0) 17 4 / 23 45 22 4 F: +49 (0) 21 51 / 65 20 88 - 88 a.schedlock@jianghai-europe.com www.jianghai-europe.com
ENGINEERED SOLUTIONS	



CAPACITOR COMPETENCE

since 1958

JIANGHAI EUROPE

Electronic Components GmbH



ENGINEERED SOLUTIONS

Jianghai Europe Electronic Components GmbH

Uerdinger Str. 95 · 47799 Krefeld/Germany

Tel.: +49 (0) 2151-652088-0 · Fax: -88

info@jianghai-europe.com

www.jianghai-europe.com

Nantong Jianghai Capacitor Co., Ltd.

No. 79 South Tong Yang Road

226361 Nantong, Jiangsu/China

Tel.: +86-513-8672-6080 · Fax: -3859

jh@jianghai.com

www.jianghai.com

Jianghai Capacitor America

12100 Wilshire Blvd. Suite 1955

Los Angeles, CA 90025 USA

Tel.: +001 706-490-3415 and +001 626-274-1692

qiwei.zhu@jhccamerica.com

yuan.wang@jhccamerica.com