



# FILM CAPACITORS

2023



DC-LINK ■ SNUBBER ■ MODULES



ENGINEERED SOLUTIONS

**JIANGHAI EUROPE**  
Electronic Components GmbH

# Capacitors from Jianghai

JIANGHAI EUROPE ELECTRONIC COMPONENTS GMBH IS THE EUROPEAN SALES ORGANIZATION OF NANTONG JIANGHAI CAPACITOR CO., LTD., NANTONG (CHINA). SINCE 2004, SALES, MARKETING, TECHNICAL SUPPORT, CUSTOMER SERVICE TEAM AND WAREHOUSE OF JIANGHAI EUROPE ELECTRONIC COMPONENTS GMBH ARE LOCATED IN KREFELD AND KEMPEN (GERMANY).

## » ELECTROLYTIC CAPACITORS

Jianghai has grown since its foundation in 1958 to become the largest Chinese manufacturer of aluminum capacitors generating revenues of more than 700 million USD in 2021. While Jianghai started in the beginning with the production of specialty chemicals (e.g., electrolyte solutions), it entered the production of aluminum electrolytic capacitors already in 1970.



## » POLYMER CAPACITORS

The year 2013 was marked by a major breakthrough in R&D for polymer aluminum electrolytic capacitors: the voltage proof for these ultra-low ESR products was pushed out to as much as 200V, enabling the utilization of these advanced capacitors in more applications, e.g. in white goods, industrial automation, telecom infrastructure, power supplies, and LED ballasts. Hybrid and Stacked (Chip) Polymer Capacitors were added into the product portfolio in the year 2019.

## » FILM CAPACITORS

In 2012, the product portfolio was complemented by a range of power film capacitors. For this new business unit, Jianghai also follows the strategy of vertical integration and thus the production will extend from the preparation of the plastic film to the assembly of the finished goods. The product portfolio includes DC Link, Snubber and Modules. Highly automated production facilities thereby ensure efficient mass production of film capacitor Modules. Driven by the thriving electric vehicle market in China, Jianghai has attained a leading position for the supply of these customer specific components.



## » INTEGRATION OF PREMATERIAL

More recently, Jianghai extended its production range by integrating high and low voltage anode foil etching and forming facilities. All factories are located in mainland China: the most important ones are in Nantong (north to Shanghai), in Inner Mongolia, and in Xi'An area. Jianghai is well prepared for further expansion due to its successful entrance to the stock market in summer 2010.

## » ENERGY CAPACITORS

For energy storage applications, Jianghai has developed a range of Lithium Ion-Capacitors (Li-C) based on the well-known EDLC technology. Li-C combine the advantage of many hundred thousand charge and discharge cycles and high energy density, allowing for a wide range of applications in energy storage and recuperation. Jianghai offers EDLC as well as Li-C in various form factors, e.g. in radial, snap-in, pouch or module shape.



## » CAPACITOR COMPETENCE CENTER

Global presence of experienced sales and technical marketing experts at offices in Europe, Asia and the Americas ensure the local support of our customers based on sound know-how in all project phases. In 2014 Jianghai Europe has established an additional service for its customers in Europe: Experts for capacitors are awaiting telephone calls or emails at the CCCenter as a kind of hotline for all kind of technical requests.

## » CUSTOMIZED PRODUCTS

Jianghai's particular strength as a volume manufacturer is to offer customized products. Jianghai focuses on the demanding professional industrial segment with many power electronics applications. Research and development in collaboration with several specialized university institutes as well as the access to all vital pre-materials enable Jianghai to create engineered, customized solutions to fit smoothly into a specific application. Jianghai is continuously improving processes, thereby enhancing the quality of its products and services. The list of certificates awarded to Jianghai reflects its level of achievement. In the year 2013, the Jianghai Europe sales office has become certified according to ISO9001 and ISO14001.

## » CONTACT

Jianghai Europe Electronic Components GmbH  
T: +49 (21 51) 65 20 88-0 | F: +49 (21 51) 65 20 88-88  
info@jianghai-europe.com | www.jianghai-europe.com

## ■ GENERAL INFORMATION

About us	1
Overview DC-LINK, Snubber and Modules	3
Handling Precautions Film Capacitors	5

## ■ DC-LINK CAPACITORS

SERIES DC-LINK	Code	Temperature		PAGE
CBB 131	DL <b>UPDATED!</b>	85°C	CYLINDRIC SCREW TERMINAL	7
CBB 131S	DY <b>UPDATED!</b>	85°C	CYLINDRIC SCREW TERMINAL	16
CBB 131G	DT <b>NEW</b>	105°C	CYLINDRIC SCREW TERMINAL	21
CBB 132	DH	105°C	CYLINDRIC SOLDERING PIN	26
CBB 136	DP <b>UPDATED!</b>	85°C	PLASTIC CASE MOUNTING	29
CBB 136G	DG <b>UPDATED!</b>	105°C	PLASTIC CASE MOUNTING	32
CBB 138	DS	105°C	SQUARE SOLDERING PIN	35

## ■ SNUBBER CAPACITORS

SERIES SNUBBER	Code	Temperature		PAGE
CBB 161	IL	105°C	FLANGE CONTACT	41
CBB 162	IP	105°C	SOLDERING PIN	46
CBB 165	IS	105°C	FLANGE CONTACT	51
CBB 166	IG	105°C	SOLDERING PIN	56

## ■ MODULES

MODULES	Code	Temperature		PAGE
CBB 133	DM	85°C	METAL HOUSING	59
CBB 135	DV	105°C	PLASTIC HOUSING	63

DC-LINK

APPLICATIONS:

- 1 High power frequency converters
- 2 Motion control, welding equipment, elevators
- 3 Electric and hybrid electric vehicles
- 4 Photovoltaic and wind inverters
- 5 Industry high-end power supplies

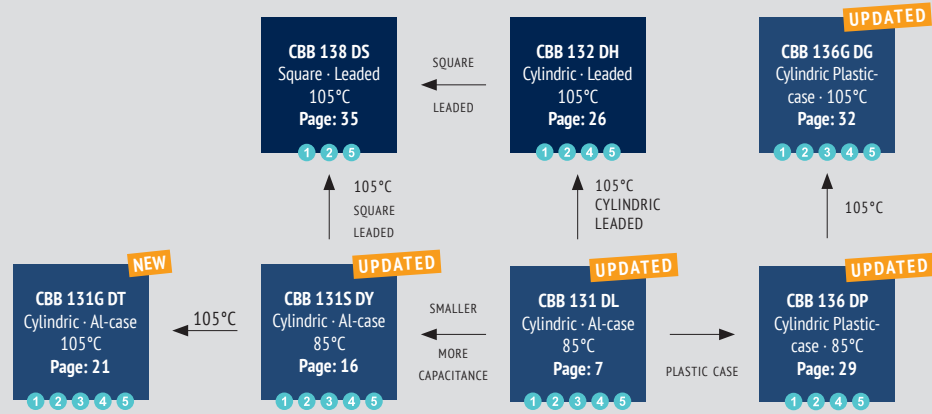

SNUBBER

APPLICATIONS:

- 1 High pulse an high frequency circuits
- 2 IGBT mounting

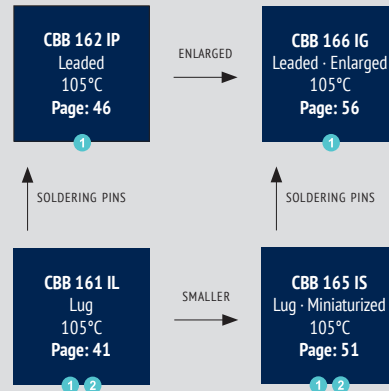

# MODULES

APPLICATIONS:

- 1 High power frequency converters
- 2 Electric and hybrid electric vehicles
- 3 Electric & hybrid electric vehicles, traction & trains

**CBB 135 DV**  
Plastic Case  
105°C  
Page: 63

1 2

**CBB 133 DM**  
Metal Housing  
85°C  
Page: 59

1 3

**WARRANTY** The information contained in this datasheet does neither form part of any quotation nor of a contract, it is believed to be accurate, reliable and up to date. Quality data are based on the statistical evaluations of a large quantity of parts and do not constitute a guarantee in a legal sense. However, agreement on these specifications does mean that the customer may claim for replacement of individual defective capacitors within the terms of delivery. We cannot assume any liability beyond the replacement of defective components. This applies in particular to any further consequences of component failure. Furthermore it must be taken into consideration that the figures stated for lifetime and failure rates refer to the average production status and are therefore to be understood as mean values (statistical expectations) for a large number of delivery lots of identical capacitors. These figures are based on application experience and data obtained from preceding tests under normal conditions, or – for purpose of accelerated aging – more severe conditions. JIANGHAI reserves the right to change these specifications without prior notice. Any application information given is advisory and does not form part of any specification. The products are not primarily designed for use in life supporting applications, devices or systems where malfunction of these products can reasonably be expected to result in personal injury. JIANGHAI customers using or selling these products for use in such applications without prior written consent of JIANGHAI do so at their own risk and agree fully to indemnify JIANGHAI for any damage resulting from such improper use or sale. This version of the datasheet supersedes all previous versions.

**NOMINAL CAPACITANCE  $C_R$**  Nominal Capacitance is defined at 20°C and 50Hz (120Hz).

**RATED VOLTAGE  $U_R$**

**DC Capacitors:**  $U_{RDC}$  Maximum operating peak voltage of either polarity but of a non-reversing type waveform, for which the capacitor has been designed, for continuous operation. The maximum DC voltage is the sum of the DC voltage and peak AC voltage.

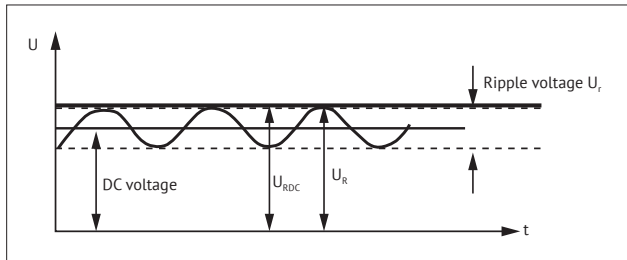

**AC Capacitors:**  $U_{RAC}$  Maximum operating peak recurrent voltage of either polarity of a reversing type waveform for which the capacitor has been designed.

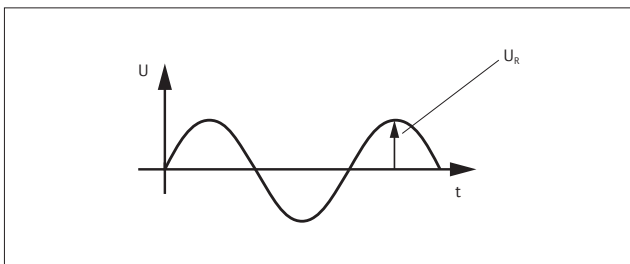

**OPERATING VOLTAGE** The plastic film capacitor varies in the maximum applicable voltage depending on the applied voltage waveform, current waveform, frequency, ambient temperature (capacitor surface temperature), capacitance value, etc. Be sure to use capacitors within the specified values by checking the voltage waveform, current waveform, and frequency applied to them (In the application of high frequency, the permissible voltage varies with the type of the capacitor. Refer to the specification for details. See also Voltage Derating tables.).

**NON-RECURRENT SURGE VOLTAGE  $U_S$**  Peak voltage induced by a switching or any other disturbance of the system which is allowed for a limited number of times and for durations shorter than the basic period.

- Maximum duration: 50 ms / pulse

- Maximum number of occurrences: 1000 (during load)

**MAXIMUM RATE OF VOLTAGE RISE  $dV/dt$**  Maximum permissible repetitive rate of voltage rise of the operational voltage.

**OPERATING CURRENT** Due to the fact that the dissipation factor of the capacitor is greater than zero, heat will be generated in any application where alternating currents or pulses occur. The resulting internal temperature rise may cause a severe deterioration of the capacitor's withstanding voltage, or may lead to a breakdown (even smoke or fire may result). Therefore, the safe use of capacitor must be within the rated voltage (or category voltage) and the permissible current ranges. The rated current must be considered by dividing into pulse current (peak current) and continuous current (rms current) depending on the break down mode, and when using, should make sure the both currents are within the permissible range.

**MAXIMUM CURRENT  $I_{MAX}$**  Maximum Rms Current for continuous operation, see Current Derating tables.

**MAXIMUM PEAK CURRENT  $\hat{I}$**  Maximum permissible repetitive peak current which can occur during continuous operation.  $\hat{I} = C_R \cdot (dV/dt)$

**MAXIMUM SURGE CURRENT  $\hat{I}_S$**

- Maximum duration: 50 ms / pulse

- Maximum number of occurrences: 1000 (during load)

**SERIES RESISTANCE  $R_S$**  Effective ohmic resistance of the conducting elements of the capacitor.

**EQUIVALENT SERIES RESISTANCE ESR** The ESR represents all ohmic resistances:  $ESR = \tan\delta/(\omega C) = R_S + \tan\delta/(\omega C)$

**DIELECTRIC DISSIPATION FACTOR  $\tan\delta_0$**  Constant dissipation factor of the dielectric material.

**LOSS FACTOR  $\tan\delta$**  The dissipation factor is the ratio between the reactive and effective power.

**HOTSPOT TEMPERATURE  $\Theta_{HOTSPOT}$**  Temperature at the hottest position inside the capacitor.  $\Theta_{hotspot} = \Theta_{ambient} + P_{loss} \cdot R_{th}$

$R_{th}$ : thermal resistance,  $P_{loss}$ : Powerloss  $P_{loss} = ESR \cdot I_{rms}^2$ ,  $\Theta_{ambient}$  = ambient temperature

**CHARGING AND DISCHARGING** Because the charging and discharging current of capacitor is obtained by the product of voltage rise rate (dV/dt) and capacitance, low voltage charging and discharging may also cause deterioration of capacitor such as shorting and open due to sudden charging and discharging current. When charging and discharging, pass through a resistance of 20Ω/V to 1000Ω/V or more to limit the current. When connecting multiple film capacitors in parallel in withstand voltage test or life test, connect a resistance of 20Ω/V to 1000Ω/V or more in series to each capacitor. In addition, **capacitors must be discharged via a resistor before handling**. Because the capacitors do not have any discharge resistors built-in, there is a risk of residual voltages and electric energy contents that might be dangerous.

**TEMPERATURE RANGE AND ALTITUDE** Use film capacitors only within the specified operating temperature range. The altitude and barometric pressure have an impact on the functionality of the capacitor. Max. Altitude: 2000m above sea level.

ALTITUDE/m	CURRENT DERATING COEFFICIENT
≤ 2 000	1,00
2 500	0,95
3 000	0,90
3 500	0,85
4 000	0,80
4 500	0,75
5 000	0,70

**EXPECTED LIFETIME** The expected lifetime of the capacitor depends on the applied voltage and the hot spot temperature during operation. For capacitors applied in different situations, the obtainable average service lives are different. Please refer to the life time diagrams of each series.

**FAILURE RATE  $\lambda$  (FAILURE IN TIME FIT)** 1 FIT = 1/10<sup>9</sup>h (1 failure per 10<sup>9</sup> components test hours),  $\lambda = r/(nt)$

r = number of failure, n = test number, t = test time

**INSULATION VOLTAGE  $U_i$**  Rms value of AC voltage designed for the insulation between terminals of the capacitor to case or earth. The insulation voltage is equal to the rated voltage of the capacitor, divided by, unless otherwise specified.

**INSULATION RESISTANCE  $R_i$**  Ration between applied DC Voltage and resulting leakage current after 1 minute of charge. It is defined in MΩ. Typically it is given as time constant  $R_i \cdot C$  [μF] in seconds.

**VOLTAGE BETWEEN TERMINALS  $U_{TT}$**  Voltage between terminals.

**VOLTAGE BETWEEN TERMINALS AND CASE  $U_{TC}$**  Voltage between terminals and case.

**BUZZING NOISE** Any buzzing noise produced by a capacitor is caused by the vibration of the film due to the Coulomb force that is generated between the electrodes with opposite poles. It is of no harm to the capacitor.

**SURFACE OVER TEMPERATURE  $\Delta\theta_{\text{case}}$**  When current continuously flow through the capacitor, the temperature inside the capacitor will rise induced by dissipated heat. If the temperature exceeds the maximum allowed hot-spot temperature, it might cause a short circuit or fire. The limits described in the catalogue must not be exceeded and it's necessary to check the temperature on the capacitor's surface in operation.

**FLAME RETARDATION** Although flame retarding PU resin or plastic case material is used in the coating or encapsulation of plastic film capacitors, continuous exposure to high temperature ambient or fire will break the coating layer or plastic case of the capacitor, and may lead to melting and ignition of the capacitor element.

**HUMID AMBIENT** If used for a long time in a humid ambient, the capacitor might absorb humidity and oxidize the electrodes causing damage to the capacitor. In case of AC application, high humidity would increase the corona effect. This phenomenon causes a drop in capacitance and an increase of capacitor losses. Humidity needs to be avoided. If needed please inform Jianghai separately for technical adopted components.

**STORAGE CONDITIONS** 1) Capacitors must not be stored in corrosive atmospheres, particularly not when chlorides, sulfides, alkali, acids, lye, salts, organic solvents or similar substances are present. 2) It must not be stored in high temperature and/or high humidity environments. The following storage conditions must be kept (applicable only for storage in the original package): Temperature:  $\leq 35\text{ }^{\circ}\text{C}$ ; Humidity:  $\leq 80\%$  RH, no dew allowed on the capacitor; Storage time:  $\leq 24$  months

**MOUNTING** Other devices, which are mounted near the capacitor, should not touch the capacitor. Additional heat coming from other components near the capacitor may reduce the lifetime of the capacitor. Do never attempt to bend or twist the capacitor after mounting and avoid any mechanical stress on the terminals. Never exceed the max. permissible torques when tightening the terminal screws or the mounting bolt's cap nuts.

**CAUTION & WARNINGS** Do not touch the terminals of capacitors. The energy stored in capacitors may be lethal. Ensure that the operating environment of the equipment into which the capacitor has been built, is within the specified conditions. Capacitors must not be used in corrosive atmospheres, particularly not when chlorides, sulfides, alkali, acid, lye, salts, organic solvents or similar substances are present. Electrical or mechanical misapplication may be hazardous. Personal injury or property damage may result from bursting of the capacitors or from expulsion of melted material.

*Jianghai Europe GmbH, v5 0123*



## FEATURES

- DC-Link
- Very low dissipation factor
- High ripple current capability
- Self-healing
- Long lifetime
- Aluminum case

## OVERVIEW

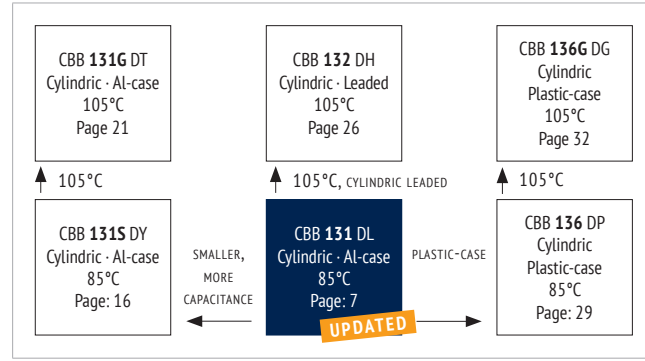

## PRODUCT



## APPLICATIONS

- High power frequency converters
- Motion control, welding equipment, elevators
- Electric and hybrid electric vehicles
- Photovoltaic and wind inverters

## CHARACTERISTICS

ITEM	CHARACTERISTICS
Climatic Category	40/85/56 (IEC 61071)
Operating Temperature	-40 ~ +85 °C ( $\theta_{\text{hotspot}} \leq 85 \text{ °C}$ )
Storage Temperature	-40 ~ +85 °C
Rated Voltage $U_{\text{RDC}}$	600 ~ 3.600V <sub>DC</sub>
Capacitance Range	44 ~ 7.200 $\mu\text{F}$
Capacitance Tolerance	$\pm 10 \%$ (K), $\pm 5 \%$ (J)
Voltage between Terminals $U_{\text{TT}}$	$1,5 \cdot U_{\text{RDC}}$ (20 °C, 10 s)
Voltage between Terminals & Case $U_{\text{TC}}$	$\geq 3.000\text{V}_{\text{AC}}$ (20°C, 50Hz, 10s)
Max. Overvoltage	Please see IEC 61071
Insulation Resistance $R_i$ °C	$\geq 10.000 \text{ M}\Omega \cdot \mu\text{F}$ (20 °C, 100 V <sub>DC</sub> , 1 min)
Dielectric Dissipation Factor $\tan \delta_o$	$\leq 2 \cdot 10^{-4}$ (20 °C, 100 Hz)
Life Time Expectancy	$\geq 100.000\text{h}$ , failure rate $\leq 50 \text{ FIT}$ ( $\theta_{\text{hotspot}} \leq 70^\circ\text{C}$ , $U_{\text{RDC}}$ )
Reference Standard	IEC 61071:2007

## ENVIRONMENTAL

The products are RoHS, WEEE and REACH compliant.

The detailed version please see separate "Environmental Certificates" document or [www.jianghai-europe.com](http://www.jianghai-europe.com)

## APPROVALS

- UL94-V0:**  
Plastic & Compound Mass
- UL810:**  
CZDS2.E227010 (Construction)  
(except Can Style C & P)

## LIFETIME

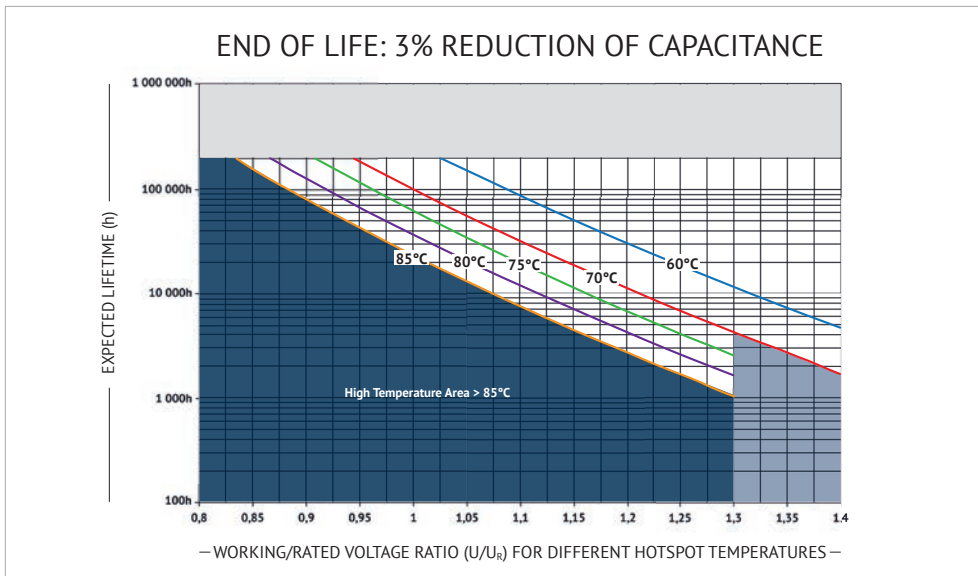

## CURRENT DERATING

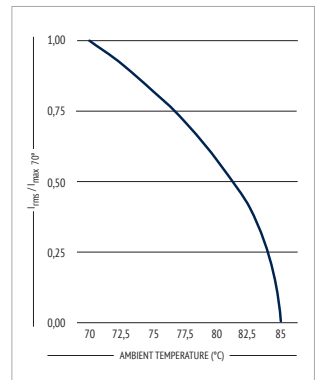

DC-LINK





■ CAN STYLES

### CAN STYLE A

$H_1 = H + 5\text{mm}$

Aluminum Case with Flanging

$D_T = 12\text{mm}^*$

M6\*10 screw female\*

**\*preferred**

### CAN STYLE B UPDATED

$H_1 = H + 5\text{mm}$

Aluminum Case with Flanging Anti-Creep Insulation

$D_T = 12\text{mm}^*$

M6\*10 screw female\*

**\*preferred**

### CAN STYLE C

$H_1 = H + 5\text{mm}$

Aluminum/Plastic Case

$D_T = 16\text{mm}^*$

M6\*10 screw female\*  
M8\*10 screw female

**\*preferred**

### CAN STYLE D

$H_1 = H + 5\text{mm}$

Aluminum/Plastic Case Enlarged Anti-Creep Insulation

$D_T = 12\text{mm}^*$

M6\*10 screw female\*

**\*preferred**

### CAN STYLE E/F/G

$H_1 = H + 5\text{mm}$

Aluminum/Plastic Case Anti-Creep Insulation

Can Style E  $D_T = 12\text{mm}$   
Can Style F  $D_T = 14\text{mm}$   
Can Style G  $D_T = 16\text{mm}$

Can Style E M6\*10 screw female  
Can Style F M6\*10 screw female  
M8\*10 screw female  
Can Style G M8\*10 screw female

**\*preferred** M10\*10 screw female

### CAN STYLE H/I

$H_1 = H + 5\text{mm}$

Aluminum/Plastic Case with Flanging Anti-Creep Insulation

Can Style H/I:  $D_T = 14\text{mm}$

M6\*10 screw female\*

**\*preferred**

DC-LINK

in mm



### CAN STYLE J/K

$H_1 = H + 5\text{mm}$

Aluminum/Plastic Case  
Anti-Creep Insulation

$D_T = 12\text{mm}^*$

M6\*10 screw female\*

### CAN STYLE L/N

$H_1 = H + 5\text{mm}$

Aluminum/Plastic Case  
Anti-Creep Insulation

Can Style L:  $D_T = 14\text{mm}$   
Can Style N:  $D_T = 14\text{mm}$

M6\*10 screw female\*  
M8\*10 screw female

\*preferred

### CAN STYLE P

$H_1 = H + 5\text{mm}$

Aluminum/Plastic Case  
Double Pole  
Anti-Creep Insulation

$D_T = 16\text{mm}^*$

M6\*10 screw female\*

\*preferred

DC-LINK

in mm

## CAN STYLE „X“

### OTHER CAN STYLES ON REQUEST

## DIMENSIONS

Diameter D ± 1,0 mm	Diameter Cab D1 ± 1,0 mm	Can Style	Pitch P ± 0,5mm	Length Cab Lc ± 1,0 mm	Diameter Terminal $D_T$ ± 0,5mm
76	-	C	32	20	16
76	-	J	32	10	12
76	-	B	32	32	12
85	-	A	32	-	12
86	-	C	32	20	16
86	89	D	32	35	12
86	-	E	32	25	12
86	-	F	32	25	14
86	-	J	32	10	12
86	-	B, K	32	32	12
89	92	D	45	35	12
96	-	C	45	20	16
116	-	A	50	-	12
116	-	C	50	40	16
116	-	H	50	10	14
116	-	I	50	45	14
116	-	P	50	40	16
116	-	L	50	10	14
116	-	N	50	45	14
136	-	G	50	35	16

Max. Torque for terminals: 3 Nm (M5), 5 Nm (M6), 6 Nm (M8), 8 Nm (M10)  
Max. Torque for stud mounting screws: 12 Nm (M12), 15Nm (M16)



### INTERNAL CONSTRUCTION

(Example: Can Style C, double inner construction)

NO.	ITEM	MATERIAL
1	Winding Core	PC
2	Metallized Film	PP + Al, Zn
3	Metal Sprayed Electrode	Zn + Sn/Zn
4	Terminals	Cu, Sn-plated
5	Deck	PC
6	Aluminum Case	Al
7	Potting Compound	PU resin (+Epoxy)
8	Connection Electrode	Cu
9	Insulation Cover	PP
10	Winding Insulation	Paper + PP

### ACCESSOIRES FOR BRACKET MOUNTING (ORDER CODE „Y“)

in mm

### MARKING

	BRAND
<b>CBB 131</b>	SERIES DESIGNATION
540µF ±10%	CAPACITANCE AND TOLERANCE
$U_R = 600V_{DC}$	$U_R$ RATED VOLTAGE
$U_{TC} = 3000V\ 50/60\ HZ$	$U_{TC}$ VOLTAGE BETWEEN TERMINALS AND CASE, FREQUENCY
-55~+85°C IEC61071	TEMPERATURE RANGE, REFERENCE STANDARD
Discharge before handling	SAFETY WARNING
E37F26104	DATE CODE

DC-LINK



### ORDER CODE

FC	C	A3	DL	427	K	K	136	0	3	1	A	1	E 3
Capacitor type	Product shape	DC rated voltage code (V)	Series code	Capacitance Code Examples (μF)	Capacitance tolerance	Diameter (mm)	Height (mm)	Terminal style	Terminal pitch (mm)	Stud bolt mounting	Can style	Inner Construction	For internal use
Film Cap. = FC	cylindrical = C	600 2S 700 2Q 800 2K 900 R2 1000 3A 1100 A3 1200 3B 1300 O3 1500 C3 1700 F3 2000 3D 2200 D2 2600 3E 2800 L3 3000 3F 3200 3U 3600 3V	CBB131 DL	100 107 220 227 420 427 500 507 1000 108 1100 118	±5% J ±10% K ±20% M	76 H 85 K 86 L 89 M 96 W 116 P 136 T	95 095 120 120 136 136 155 155 175 175 225 225 230 230	Female M5*7 8 Female M6*10 0 Female M8*10 2 Female M8*12 6 Female M10*10 4 Female M10*12 B Male M6*20 1 Male M8*12 9 Male M8*15 A Male M8*17 7 Male M8*20 3 Male M10*20 5	32 3 45 4 50 5 60 6	flat, with Y bracket Y flat, without bracket 0 bolt M12x16 1 bolt M16x25 2 bolt M12x12 3	Style A A Style B B Style C C Style D D Style E E Style F F Style G G Style H H Style I I Style J J Style K K Style L L Style N N Style P P	1 2 3	

### RATINGS

U <sub>r</sub> ≤85°C (V <sub>oc</sub> )	C <sub>r</sub> (μF)	I <sub>max</sub>				İ <sup>(1)</sup> (A)	ESR <sub>typ</sub> 20°C, 1kHz (mΩ)	R <sub>th</sub> <sup>(2)</sup> (K/W)	L <sub>s</sub> 20°C (nH)	D ±1,0 (mm)	H ±1,0 (mm)	ORDER CODE  *# to be defined, see ordering code table
		70°C, 1kHz (A)	60°C, 1kHz (A)	50°C, 1kHz (A)	≤40°C, 1kHz (A)							
600 2S	480	35	50	61	70	4800	1,6	5,1	≤50	76	95	FCC2SDL487#H095#3##1E3
	650	38,6	55	67	77	5200	1,2	5,6	≤50	85/86	95	FCC2SDL657##095#3##1E3
	650	33	47	58	67	5200	1,9	4,7	≤60	76	120	FCC2SDL657#H120#3##1E3
	770	32,5	46	56	65	6160	2,2	4,3	≤60	76	136	FCC2SDL777#H136#3##1E3
	880	37	53	65	75	6248	1,5	4,8	≤60	85/86	120	FCC2SDL887##120#3##1E3
	950	41	58	71	82	6650	1,4	4,2	≤60	76	175	FCC2SDL957#H175#3##2E3
	1000	34	49	60	70	6700	1,8	4,6	≤60	85/86	136	FCC2SDL108##136#3##1E3
	1100	40	57	70	81	6600	1,4	4,4	≤50	85/86	155	FCC2SDL118##155#3##2E3
	1200	48	68	83	96	7200	0,8	5,4	≤50	116	95	FCC2SDL128#P095#5##1E3
	1300	41	58	71	82	7800	1,4	4,3	≤60	85/86	175	FCC2SDL138##175#3##2E3
	1600	44	63	77	89	9600	1,0	5,0	≤60	116	120	FCC2SDL168#P120#5##1E3
	1800	47	67	83	95	10800	1,1	4,0	≤60	85/86	225	FCC2SDL188##225#3##2E3
	1900	43	61	75	86	11400	1,1	4,9	≤60	116	136	FCC2SDL198#P136#5##1E3
	2100	52	74	90	100	11550	0,8	4,6	≤60	116	155	FCC2SDL218#P155#5##2E3
	2400	50	70	86	99	12000	0,9	4,5	≤60	116	175	FCC2SDL248#P175#5##2E3
3000	68	96	100	100	15000	0,8	2,7	≤60	116	230	FCC2SDL308#P230#5##2E3	
700 2Q	350	35	50	61	70	3600	1,6	5,1	≤60	76	95	FCC2QDL357#H095#3##1E3
	480	31	45	55	64	3840	2,1	4,7	≤60	76	120	FCC2QDL487#H120#3##1E3
	480	36	51	62	71	3840	1,4	5,6	≤60	85/86	95	FCC2QDL487##095#3##1E3
	580	30	43	52	60	5800	2,4	4,6	≤60	76	136	FCC2QDL587#H136#3##1E3
	620	39	56	68	79	6200	1,5	4,3	≤60	76	155	FCC2QDL627#H155#3##1E3
	700	38	55	67	77	7200	1,6	4,2	≤60	76	175	FCC2QDL707#H175#3##1E3
	750	32	47	57	66	7200	2,0	4,6	≤60	86	136	FCC2QDL757#L136#3##1E3
	780	33	48	59	68	7800	1,9	4,6	≤60	86	136	FCC2QDL787#L136#3##1E3
	920	51	73	89	100	9200	0,7	5,4	≤60	116	95	FCC2QDL927#P095#5##1E3
	950	39	56	68	79	9500	1,5	4,3	≤60	86	175	FCC2QDL957#L175#3##2E3
	1200	44	63	77	89	7200	1,0	5,0	≤60	116	120	FCC2QDL128#P120#5##2E3
	1500	43	61	75	86	9000	1,1	4,9	≤60	116	136	FCC2QDL158#P136#5##1E3
	1500	52	74	90	100	9000	0,8	4,6	≤60	116	155	FCC2QDL158#P155#5##2E3
	1800	47	67	82	94	10800	1,0	4,5	≤60	116	175	FCC2QDL188#P175#5##2E3
	2300	68	96	100	100	13800	0,8	2,7	≤60	116	230	FCC2QDL238#P230#5##2E3

(1) Maximum permissible peak current, (2) Thermal resistance from hotspot to ambient (free convection)





U <sub>R</sub> ≤85°C (V <sub>DC</sub> )	C <sub>R</sub> (µF)	I <sub>max</sub>				f̂ <sup>(1)</sup> (A)	ESR <sub>typ</sub> 20°C, 1kHz (mΩ)	R <sub>th</sub> <sup>(2)</sup> (K/W)	L <sub>s</sub> 20°C (nH)	D ±1,0 (mm)	H ±1,0 (mm)	ORDER CODE
		70°C, 1kHz (A)	60°C, 1kHz (A)	50°C, 1kHz (A)	≤40°C, 1kHz (A)							
<b>800 2K</b>	280	34	48	59	68	2800	1,7	5,1	≤50	76	95	FCC2KDL287#H095#3##1E3
	370	35	49	60	69	3700	1,5	5,6	≤50	85/86	95	FCC2KDL377##095#3##1E3
	380	31	44	54	62	3800	2,2	4,7	≤60	76	120	FCC2KDL387#H120#3##1E3
	430	28	40	49	57	4300	2,6	4,6	≤60	76	136	FCC2KDL437#H136#3##1E3
	470	38	54	66	76	4700	1,6	4,3	≤60	76	155	FCC2KDL477#H155#3##2E3
	510	34	48	59	68	5100	1,8	4,8	≤60	85/86	120	FCC2KDL517##120#3##1E3
	560	37	53	65	75	5600	1,7	4,2	≤60	76	175	FCC2KDL567#H175#3##2E3
	580	33	47	57	65	5800	2,0	4,6	≤60	85/86	136	FCC2KDL587##136#3##1E3
	640	39	55	67	77	6400	1,5	4,4	≤50	85/86	155	FCC2KDL647##155#3##2E3
	710	41	58	71	82	7100	1,1	5,4	≤50	116	95	FCC2KDL717#P095#5##1E3
	750	42	60	73	85	7500	1,3	4,3	≤60	85/86	175	FCC2KDL757##175#3##2E3
	970	40	58	71	82	7760	1,2	5,0	≤60	116	120	FCC2KDL977#P120#5##1E3
	1000	42	60	73	85	8000	1,4	4,0	≤60	85/86	225	FCC2KDL108##225#3##2E3
	1000	38	54	66	76	8000	1,4	4,9	≤60	116	136	FCC2KDL108#P136#5##1E3
	1200	52	74	90	100	9600	0,8	4,6	≤60	116	155	FCC2KDL128#P155#5##2E3
	1400	53	75	91	100	11200	0,8	4,5	≤60	116	175	FCC2KDL148#P175#5##2E3
	1800	60	86	100	100	11700	1,0	2,7	≤60	116	230	FCC2KDL188#P230#5##2E3
	2000	63	90	100	100	12000	0,7	3,5	≤80	136	175	FCC2KDL208#T175#5##2E3
	2700	65	93	100	100	16200	0,8	2,9	≤80	136	230	FCC2KDL278#T230#5##2E3
3100	70	100	100	100	18600	1,0	2,0	≤80	136	252	FCC2KDL318#T252#5##2E3	
3300	71	100	100	100	19800	0,9	2,2	≤80	116	345	FCC2KDL338#P345#5##3E3	
4300	78	100	100	100	25800	0,9	1,8	≤80	136	345	FCC2KDL438#T345#5##3E3	
<b>900 R2</b>	280	31	44	54	63	2800	2,0	5,1	≤50	76	95	FCCR2DL287#H095#3##1E3
	370	33	47	58	67	3700	1,6	5,6	≤50	85/86	95	FCCR2DL377##095#3##1E3
	380	28	40	49	56	3800	2,6	4,7	≤60	76	120	FCCR2DL387#H120#3##1E3
	430	27	39	47	55	4300	2,9	4,6	≤60	76	136	FCCR2DL437#H136#3##1E3
	470	36	52	64	74	4700	1,7	4,3	≤60	76	155	FCCR2DL477#H155#3##2E3
	510	31	44	54	63	5100	2,1	4,8	≤60	85/86	120	FCCR2DL517##120#3##1E3
	560	34	49	60	69	5600	2,0	4,2	≤60	76	175	FCCR2DL567#H175#3##2E3
	580	31	44	54	62	5800	2,2	4,6	≤60	85/86	136	FCCR2DL587##136#3##1E3
	640	39	55	67	77	6400	1,5	4,4	≤50	85/86	155	FCCR2DL647##155#3##2E3
	710	39	56	68	79	7100	1,2	5,4	≤50	116	95	FCCR2DL717#P095#5##1E3
	750	38	53	66	76	7500	1,6	4,3	≤60	85/86	175	FCCR2DL757##175#3##2E3
	970	39	55	68	79	7600	1,3	5,0	≤60	116	120	FCCR2DL977#P120#5##1E3
	1000	40	58	71	82	8000	1,5	4,0	≤60	85/86	225	FCCR2DL108##225#3##2E3
	1000	36	52	64	74	8000	1,5	4,9	≤60	116	136	FCCR2DL108#P136#5##1E3
	1200	47	66	81	93	9600	1,0	4,6	≤60	116	155	FCCR2DL128#P155#5##2E3
	1400	50	70	86	99	11200	0,9	4,5	≤60	116	175	FCCR2DL148#P175#5##2E3
	1800	58	82	100	100	11700	1,1	2,7	≤60	116	230	FCCR2DL188#P230#5##2E3
	2000	70	100	100	100	12000	0,8	2,5	≤80	136	175	FCCR2DL208#T175#5##2E3
	2700	61	88	100	100	16200	0,9	2,9	≤80	136	230	FCCR2DL278#T230#5##2E3
3100	67	95	100	100	18600	1,1	2,0	≤80	136	252	FCCR2DL318#T252#5##2E3	
3300	67	95	100	100	19800	1,0	2,2	≤80	116	345	FCCR2DL338#P345#5##3E3	
4300	74	100	100	100	25800	1,0	1,8	≤80	136	345	FCCR2DL438#T345#5##3E3	
<b>1000 3A</b>	220	29	40	50	57	2420	2,4	5,1	≤50	76	95	FCC3ADL227#H095#3##1E3
	290	31	44	54	62	3190	1,8	5,6	≤50	85/86	95	FCC3ADL297##095#3##1E3
	300	27	38	46	54	3300	2,9	4,7	≤60	76	120	FCC3ADL307#H120#3##1E3
	330	25	36	44	51	3630	3,3	4,6	≤60	76	136	FCC3ADL337#H136#3##1E3
	360	35	49	60	69	3960	1,4	4,3	≤60	76	155	FCC3ADL367#H155#3##2E3
	400	30	42	52	60	4400	2,3	4,8	≤60	85/86	120	FCC3ADL407##120#3##1E3
	420	34	49	60	69	4620	2,0	4,2	≤60	76	175	FCC3ADL427#H175#3##2E3
	450	32	46	56	64	4950	2,1	4,6	≤60	85/86	136	FCC3ADL457##136#3##1E3
	500	37	52	65	75	5000	1,6	4,4	≤50	85/86	155	FCC3ADL507##155#3##2E3
	540	39	56	68	79	5400	1,2	5,4	≤50	116	95	FCC3ADL547#P095#5##1E3
	560	37	52	64	73	5600	1,7	4,3	≤60	85/86	175	FCC3ADL567##175#3##2E3
	740	39	55	68	79	7400	1,3	5,0	≤60	116	120	FCC3ADL747#P120#5##1E3
	810	45	65	79	91	8100	1,6	3,0	≤60	85/86	225	FCC3ADL817##225#3##2E3
	860	35	51	62	71	8600	1,6	4,9	≤60	116	136	FCC3ADL867#P136#5##1E3
	900	49	70	85	98	8760	0,9	4,6	≤60	116	155	FCC3ADL907#P155#5##2E3
	1100	50	70	86	99	8800	0,9	4,5	≤60	116	175	FCC3ADL118#P175#5##2E3
	1400	58	82	100	100	11200	1,1	2,7	≤60	116	230	FCC3ADL148#P230#5##2E3
	1500	70	100	100	100	12000	0,8	2,5	≤80	136	175	FCC3ADL158#T175#5##2E3
	2100	61	88	100	100	12600	0,9	2,9	≤80	136	230	FCC3ADL218#T230#5##2E3
2200	64	91	100	100	13200	1,1	2,2	≤80	116	345	FCC3ADL228#P345#5##3E3	

(1) Maximum permissible peak current, (2) Thermal resistance from hotspot to ambient (free convection)





U <sub>R</sub> ≤85°C (V <sub>DC</sub> )	C <sub>R</sub> (μF)	I <sub>max</sub>				İ <sup>(1)</sup> (A)	ESR <sub>typ</sub> 20°C, 1kHz (mΩ)	R <sub>th</sub> <sup>(2)</sup> (K/W)	L <sub>s</sub> 20°C (nH)	D ±1,0 (mm)	H ±1,0 (mm)	ORDER CODE  *R to be defined, see ordering code table
		70°C, 1kHz (A)	60°C, 1kHz (A)	50°C, 1kHz (A)	≤40°C, 1kHz (A)							
		70°C, 1kHz (A)	60°C, 1kHz (A)	50°C, 1kHz (A)	≤40°C, 1kHz (A)							
<b>1100 A3</b>	170	27	38	47	54	2040	2,7	5,1	≤50	76	95	FCCA3DL177#H095#3##1E3
	240	31	43	53	61	2880	1,9	5,6	≤50	85/86	95	FCCA3DL247##095#3##1E3
	240	26	37	45	52	2880	3,1	4,7	≤60	76	120	FCCA3DL247#H120#3##1E3
	270	25	36	44	51	3240	3,4	4,6	≤60	76	136	FCCA3DL277#H136#3##1E3
	300	34	48	59	68	3600	2,0	4,3	≤60	76	155	FCCA3DL307#H155#3##2E3
	320	30	41	51	58	3840	2,4	4,8	≤60	85/86	120	FCCA3DL327##120#3##1E3
	350	32	46	56	64	4200	2,3	4,2	≤60	76	175	FCCA3DL357#H175#3##2E3
	420	30	43	52	60	5040	2,4	4,6	≤60	85/86	136	FCCA3DL427##136#3##1E3
	420	40	57	70	81	5040	1,4	4,4	≤50	85/86	155	FCCA3DL427##155#3##2E3
	450	37	53	65	75	5400	1,3	5,4	≤50	116	95	FCCA3DL457#P095#5##1E3
	480	35	50	62	71	5760	1,8	4,3	≤60	85/86	175	FCCA3DL487##175#3##2E3
	620	36	52	63	73	6200	1,5	5,0	≤60	116	120	FCCA3DL627#P120#5##1E3
	650	37	53	65	75	6500	1,8	4,0	≤60	85/86	225	FCCA3DL657##225#3##2E3
	690	34	49	60	69	6900	1,7	4,9	≤60	116	136	FCCA3DL697#P136#5##1E3
	770	47	66	81	93	7700	1,0	4,6	≤60	116	155	FCCA3DL777#P155#5##2E3
	910	47	67	82	94	9100	1,0	4,5	≤60	116	175	FCCA3DL917#P175#5##2E3
	1200	55	79	96	100	9600	1,2	2,7	≤60	116	230	FCCA3DL128#P230#5##2E3
	1200	66	94	100	100	9600	0,9	2,5	≤80	136	175	FCCA3DL128#T175#5##2E3
1700	58	83	100	100	13600	1,0	2,9	≤80	136	230	FCCA3DL178#T230#5##2E3	
1900	67	95	100	100	15200	1,1	2,0	≤80	136	252	FCCA3DL198#T252#5##2E3	
2000	59	84	100	100	16000	1,3	2,2	≤80	116	345	FCCA3DL208#P345#5##3E3	
2900	74	100	100	100	23200	1,0	1,8	≤80	136	345	FCCA3DL298#T345#5##3E3	
<b>1200 3B</b>	140	26	36	44	51	1680	3,0	5,1	≤50	76	95	FCC3BDL147#H095#3##1E3
	190	29	41	51	58	2280	2,1	5,6	≤50	85/86	95	FCC3BDL197##095#3##1E3
	200	25	35	43	50	2400	3,4	4,7	≤50	76	120	FCC3BDL207#H120#3##1E3
	220	24	34	42	48	2640	3,7	4,6	≤60	76	136	FCC3BDL227#H136#3##1E3
	240	32	46	56	65	2880	2,2	4,3	≤60	76	155	FCC3BDL247#H155#3##2E3
	260	27	39	48	55	3120	2,7	4,8	≤60	85/86	120	FCC3BDL267##120#3##1E3
	280	30	44	53	62	3360	2,5	4,2	≤60	76	175	FCC3BDL287#H175#3##2E3
	300	28	41	50	58	3600	2,6	4,6	≤60	85/86	136	FCC3BDL307##136#3##1E3
	350	35	50	61	71	3960	1,8	4,4	≤50	85/86	155	FCC3BDL357##155#3##2E3
	360	36	51	63	73	4320	1,4	5,4	≤50	116	95	FCC3BDL367#P095#5##1E3
	380	35	51	62	72	4560	1,8	4,3	≤60	85/86	175	FCC3BDL387##175#3##2E3
	500	34	49	59	69	5500	1,7	5,0	≤60	116	120	FCC3BDL507#P120#5##1E3
	540	35	50	61	71	5940	2,0	4,0	≤60	85/86	225	FCC3BDL547##225#3##2E3
	570	32	46	57	66	6270	1,9	4,9	≤60	116	136	FCC3BDL577#P136#5##1E3
	620	44	63	77	89	6820	1,1	4,6	≤60	116	155	FCC3BDL627#P155#5##2E3
	720	43	60	74	86	7920	1,2	4,5	≤60	116	175	FCC3BDL727#P175#5##2E3
	950	53	75	92	100	9500	1,3	2,7	≤60	116	230	FCC3BDL957#P230#5##2E3
	1000	63	89	100	100	10000	1,0	2,5	≤80	136	175	FCC3BDL108#T175#5##2E3
	1400	55	79	97	100	14000	1,1	2,9	≤80	136	230	FCC3BDL148#T230#5##2E3
	1600	64	91	100	100	16000	1,2	2,0	≤80	136	252	FCC3BDL168#T252#5##2E3
	1600	67	95	100	100	16000	1,0	2,2	≤80	116	345	FCC3BDL168#P345#5##3E3
2200	74	100	100	100	23200	1,0	1,8	≤80	136	345	FCC3BDL228#T345#5##3E3	
<b>1300 03</b>	120	24	34	42	49	1440	3,3	5,1	≤50	76	95	FCCO3DL127#H095#3##1E3
	160	28	39	48	56	1920	2,3	5,6	≤50	85/86	95	FCCO3DL167##095#3##1E3
	160	23	34	42	48	1920	3,7	4,7	≤60	76	120	FCCO3DL167#H120#3##1E3
	180	23	33	40	46	2160	4,1	4,6	≤60	76	136	FCCO3DL187#H136#3##1E3
	210	31	44	54	62	2520	2,4	4,3	≤60	76	155	FCCO3DL217#H155#3##2E3
	220	28	40	49	57	2640	2,6	4,8	≤60	85/86	120	FCCO3DL227##120#3##1E3
	240	29	41	51	58	2880	2,8	4,2	≤60	76	175	FCCO3DL247#H175#3##2E3
	250	27	39	47	55	3000	2,9	4,6	≤60	85/86	136	FCCO3DL257##136#3##1E3
	280	36	52	63	73	3360	1,7	4,4	≤50	85/86	155	FCCO3DL287##155#3##2E3
	310	34	48	59	68	3720	1,6	5,4	≤50	116	95	FCCO3DL317#P095#5##1E3
	320	34	49	61	70	3840	1,9	4,3	≤60	85/86	175	FCCO3DL327##175#3##2E3
	420	33	47	58	67	5040	1,8	5,0	≤60	116	120	FCCO3DL427#P120#5##1E3
	450	33	48	58	67	5400	2,2	4,0	≤60	85/86	225	FCCO3DL457##225#3##2E3
	480	31	44	54	62	5760	2,1	4,9	≤60	116	136	FCCO3DL487#P136#5##1E3
	530	44	63	77	89	6360	1,1	4,6	≤60	116	155	FCCO3DL537#P155#5##2E3
	630	45	64	78	90	7560	1,1	4,5	≤60	116	175	FCCO3DL637#P175#5##2E3
	820	49	70	86	99	9840	1,5	2,7	≤60	116	230	FCCO3DL827#P230#5##2E3
	880	60	85	100	100	10560	1,1	2,5	≤80	136	175	FCCO3DL887#T175#5##2E3
	1200	53	76	93	100	13200	1,2	2,9	≤80	136	230	FCCO3DL128#T230#5##2E3
	1300	62	88	100	100	14300	1,3	2,0	≤80	136	252	FCCO3DL138#T252#5##2E3
	1400	61	87	100	100	15400	1,2	2,2	≤80	116	345	FCCO3DL148#P345#5##3E3
	1900	68	96	100	100	20900	1,2	1,8	≤80	136	345	FCCO3DL198#T345#5##3E3

DC-LINK

(1) Maximum permissible peak current, (2) Thermal resistance from hotspot to ambient (free convection)





U <sub>r</sub> ≤85°C (V <sub>oc</sub> )	C <sub>r</sub> (μF)	I <sub>max</sub>				İ <sup>(1)</sup> (A)	ESR <sub>typ</sub> 20°C, 1kHz (mΩ)	R <sub>th</sub> <sup>(2)</sup> (K/W)	L <sub>s</sub> 20°C (nH)	D ±1,0 (mm)	H ±1,0 (mm)	ORDER CODE
		70°C, 1kHz (A)	60°C, 1kHz (A)	50°C, 1kHz (A)	≤40°C, 1kHz (A)							
<b>1500</b> C3	170	26	37	45	52	2040	3,1	4,8	≤60	85/86	120	FCCC3DL177##120#3##1E3
	210	33	48	58	67	2520	2,0	4,4	≤60	85/86	155	FCCC3DL217##155#3##2E3
	310	30	44	53	62	3720	2,1	5,0	≤60	116	120	FCCC3DL317#P120#5##1E3
	330	31	45	55	63	3960	2,5	4,0	≤60	85/86	225	FCCC3DL337##225#3##2E3
	400	39	56	68	79	4800	1,4	4,6	≤60	116	155	FCCC3DL407#P155#5##2E3
	600	46	66	81	93	7200	1,7	2,7	≤60	116	230	FCCC3DL607#P230#5##2E3
	1000	70	100	100	100	12000	1,0	2,0	≤80	136	252	FCCC3DL108#T252#5##2E3
	1000	67	95	100	100	12000	1,0	2,2	≤80	116	345	FCCC3DL108#P345#5##3E3
1400	74	100	100	100	16800	1,0	1,8	≤80	136	345	FCCC3DL148#T345#5##3E3	
<b>1700</b> F3	130	24	35	42	49	1560	3,5	4,8	≤60	85/86	120	FCCF3DL137##120#3##1E3
	160	31	44	54	63	1920	2,3	4,4	≤60	85/86	155	FCCF3DL167##155#3##2E3
	240	25	35	43	50	2880	3,2	5,0	≤60	116	120	FCCF3DL247#P120#5##1E3
	250	29	42	51	59	3000	2,9	4,0	≤60	85/86	225	FCCF3DL257##225#3##2E3
	300	26	38	46	53	3600	3,0	4,6	≤60	116	155	FCCF3DL307#P155#5##2E3
	460	36	51	62	72	5520	2,8	2,7	≤60	116	230	FCCF3DL467#P230#5##2E3
	760	44	63	77	89	9120	2,5	2,0	≤80	136	252	FCCF3DL767#T252#5##2E3
<b>2000</b> 3D	100	23	32	40	46	1200	4,0	4,8	≤60	85/86	120	FCC3DDL107##120#3##1E3
	120	24	34	42	48	1440	3,8	4,4	≤60	85/86	155	FCC3DDL127##155#3##2E3
	190	27	38	47	54	2280	2,7	5,0	≤60	116	120	FCC3DDL197#P120#5##1E3
	190	27	39	48	55	2280	3,3	4,0	≤60	85/86	225	FCC3DDL197##225#3##2E3
	240	35	49	60	70	2880	1,8	4,6	≤60	116	155	FCC3DDL247#P155#5##2E3
	370	41	58	71	82	4440	2,2	2,7	≤60	116	230	FCC3DDL377#P230#5##2E3
	600	61	87	100	100	6000	1,2	2,2	≤80	116	345	FCC3DDL607#P345#5##3E3
	600	64	91	100	100	6000	1,2	2,0	≤80	136	252	FCC3DDL607#T252#5##1E3
	800	71	100	100	100	9600	1,1	1,8	≤80	136	345	FCC3DDL807#T345#5##3E3
<b>2200</b> D2	90	24	34	42	48	1080	3,7	4,6	≤60	86	136	FCCD2DL906#L136#3##1E3
	140	30	43	52	60	1680	2,2	5,0	≤60	116	120	FCCD2DL147#P120#5##2E3
	150	36	51	63	73	1800	1,9	4,0	≤60	86	225	FCCD2DL157#L225#3##2E3
	170	29	42	51	59	2040	2,5	4,6	≤60	116	155	FCCD2DL177#P155#5##2E3
	210	45	64	78	90	2520	1,1	4,5	≤60	116	175	FCCD2DL217#P175#5##2E3
	290	51	73	89	100	3480	1,4	2,7	≤60	116	230	FCCD2DL297#P230#5##2E3
	400	53	76	93	100	4800	1,2	2,9	≤80	136	230	FCCD2DL407#T230#5##2E3
	450	61	87	100	100	5400	1,2	2,2	≤80	116	345	FCCD2DL457#P345#5##3E3
	500	62	87	100	100	6000	1,3	2,0	≤80	136	252	FCCD2DL507#T252#5##2E3
	660	71	100	100	100	7920	1,1	1,8	≤80	136	345	FCCD2DL667#T345#5##3E3
	<b>2600</b> 3E	63	23	33	41	47	756	4,1	4,4	≤60	86	155
100		32	46	56	65	1200	2,4	4,0	≤60	86	225	FCC3EDL107#L225#3##1E3
100		28	40	50	57	1200	2,4	5,0	≤60	116	120	FCC3EDL107#P120#5##2E3
120		28	40	49	57	1440	2,7	4,6	≤60	116	155	FCC3EDL127#P155#5##2E3
140		43	61	75	86	1680	1,2	4,5	≤60	116	175	FCC3EDL147#P175#5##2E3
200		49	70	86	99	2400	1,5	2,7	≤60	116	230	FCC3EDL207#P230#5##1E3
200		60	85	100	100	2400	1,1	2,5	≤80	136	175	FCC3EDL207#T175#5##2E3
280		51	73	89	100	3360	1,3	2,9	≤80	136	230	FCC3EDL287#T230#5##2E3
320		56	81	99	100	3840	1,4	2,2	≤80	116	345	FCC3EDL327#P345#5##3E3
340		59	85	100	100	4080	1,4	2,0	≤80	136	252	FCC3EDL347#T252#5##2E3
450		65	92	100	100	5400	1,3	1,8	≤80	136	345	FCC3EDL457#T345#5##3E3
<b>2800</b> L3		86	28	40	49	57	1032	2,5	5,0	≤60	116	120
	88	33	48	58	67	1056	2,2	4,0	≤60	86	225	FCCL3DL886#L225#3##1E3
	100	26	38	46	53	1200	2,9	4,9	≤60	116	136	FCCL3DL107#P136#5##1E3
	120	33	46	56	65	1440	2,1	4,5	≤60	116	175	FCCL3DL127#P175#5##2E3
	170	51	73	89	100	2040	1,5	2,5	≤80	136	175	FCCL3DL177#T175#5##2E3
	240	49	70	87	100	2880	1,4	2,9	≤80	136	230	FCCL3DL247#T230#5##2E3
	270	56	81	99	100	3240	1,4	2,2	≤80	116	345	FCCL3DL277#P345#5##3E3
	290	55	79	97	100	3480	1,6	2,0	≤80	136	252	FCCL3DL297#T252#5##2E3
	390	68	92	100	100	4680	1,2	1,8	≤80	136	345	FCCL3DL397#T345#5##3E3
	<b>3000</b> 3F	46	21	31	38	43	552	4,6	4,6	≤60	86	136
74		27	39	48	55	888	2,6	5,0	≤60	116	120	FCC3FDL746#P120#5##1E3
75		32	47	57	66	900	2,3	4,0	≤60	86	225	FCC3FDL756#L225#3##1E3
100		41	58	72	83	1200	1,3	4,5	≤60	116	175	FCC3FDL107#P175#5##2E3
140		50	71	87	100	1680	1,6	2,5	≤80	136	175	FCC3FDL147#T175#5##2E3

(1) Maximum permissible peak current, (2) Thermal resistance from hotspot to ambient (free convection)





U <sub>R</sub> ≤85°C (V <sub>DC</sub> )	C <sub>R</sub> (μF)	I <sub>max</sub>				İ <sup>(1)</sup> (A)	ESR <sub>typ</sub> 20°C, 1kHz (mΩ)	R <sub>th</sub> <sup>(2)</sup> (K/W)	L <sub>s</sub> 20°C (nH)	D ±1,0 (mm)	H ±1,0 (mm)	ORDER CODE
		70°C, 1kHz (A)	60°C, 1kHz (A)	50°C, 1kHz (A)	≤40°C, 1kHz (A)							
<b>3000 3F</b>	200	49	70	86	99	2400	1,4	2,9	≤80	136	230	FCC3FDL207#T230#5##2E3
	240	64	91	100	100	2880	1,1	2,2	≤80	116	345	FCC3FDL247#P345#5##3E3
	250	64	91	100	100	3000	1,2	2,0	≤80	136	252	FCC3FDL257#T252#5##2E3
	330	74	100	100	100	3960	1,0	1,8	≤80	136	345	FCC3FDL337#T345#5##3E3
<b>3200 3U</b>	64	27	38	47	54	768	2,7	5,0	≤60	116	120	FCC3UDL646#P120#5##1E3
	65	22	32	39	45	780	4,9	4,0	≤60	86	225	FCC3UDL656#L225#3##1E3
	92	41	58	72	83	1104	1,3	4,5	≤60	116	175	FCC3UDL926#P175#5##2E3
	120	48	69	84	97	1440	1,7	2,5	≤80	136	175	FCC3UDL127#T175#5##2E3
	180	49	70	86	99	2160	1,4	2,9	≤80	136	230	FCC3UDL187#T230#5##2E3
	210	59	83	100	100	2520	1,3	2,2	≤80	116	345	FCC3UDL217#P345#5##3E3
	220	59	85	100	100	2640	1,4	2,0	≤80	136	252	FCC3UDL227#T252#5##2E3
	300	68	96	100	100	3600	1,2	1,8	≤80	136	345	FCC3UDL307#T345#5##3E3
<b>3600 3V</b>	44	29	42	51	59	528	2,3	5,0	≤60	116	120	FCC3VDL446#P120#5##1E3
	45	35	50	61	71	540	2,0	4,0	≤60	86	225	FCC3VDL456#L225#3##1E3
	88	51	73	89	100	1056	1,4	2,7	≤60	116	230	FCC3VDL886#P230#5##2E3
	120	51	73	89	100	1440	1,3	2,9	≤80	136	230	FCC3VDL127#T230#5##2E3
	160	61	86	100	100	1920	1,2	2,2	≤80	116	345	FCC3VDL167#P345#5##3E3
	170	62	88	100	100	2040	1,3	2,0	≤80	136	252	FCC3VDL177#T252#5##2E3
	230	74	100	100	100	2760	1,0	1,8	≤80	136	345	FCC3VDL237#T345#5##3E3

(1) Maximum permissible peak current, (2) Thermal resistance from hotspot to ambient (free convection)

DC-LINK





**FEATURES**

- DC-Link
- Miniaturized
- Higher Capacitance
- Low ESR, high Currents
- Self-healing
- Long Lifetime
- Aluminum case

**OVERVIEW**

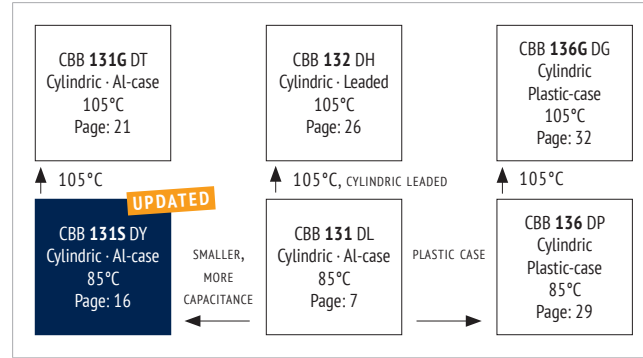

**PRODUCT**



**APPLICATIONS**

- Photovoltaic and wind inverters
- Electric and hybrid electric vehicles
- Motion control, welding equipment, elevators
- High power frequency converters

**CHARACTERISTICS**

ITEM	CHARACTERISTICS
Climatic Category	40/85/56 (IEC 61071)
Operating Temperature	-40 ~ +85 °C ( $\theta_{hotspot} \leq 85$ °C)
Storage Temperature	-40 ~ +85 °C
Rated Voltage $U_{RDC}$	600 ~ 1.500V <sub>DC</sub>
Capacitance Range	110 ~ 1.600 $\mu$ F
Capacitance Tolerance	$\pm 10$ % (K), $\pm 5$ % (J)
Voltage between Terminals $U_{TT}$	$1,5 \cdot U_{RDC}$ (20 °C, 10 s)
Voltage between Terminals & Case $U_{TC}$	$\geq 3.000V_{AC}$ (20°C, 50Hz, 10s)
Max. Overvoltage	Please see IEC 61071
Insulation Resistance $R_i$ *C	$\geq 10.000 M\Omega \cdot \mu$ F (20 °C, 100 V <sub>DC</sub> , 1 min)
Dielectric Dissipation Factor $\tan \delta_0$	$\leq 2 \cdot 10^{-4}$ (20 °C, 100 Hz)
Life Time Expectancy	$\geq 100.000h$ , failure rate $\leq 100$ FIT ( $\theta_{hotspot} \leq 70^\circ C, U_{RDC}$ )
Reference Standard	IEC 61071:2007

**ENVIRONMENTAL**

The products are RoHS, WEEE and REACH compliant.  
The detailed version please see separate "Environmental Certificates" document or [www.jianghai-europe.com](http://www.jianghai-europe.com)

**APPROVALS**

**UL94-V0:**  
Plastic & Compound Mass

**LIFETIME**

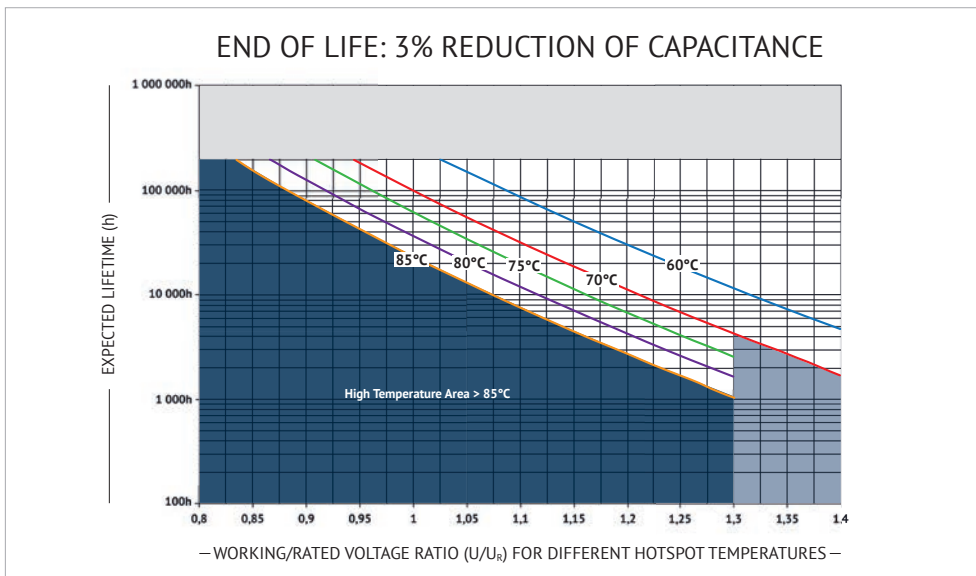

**CURRENT DERATING**

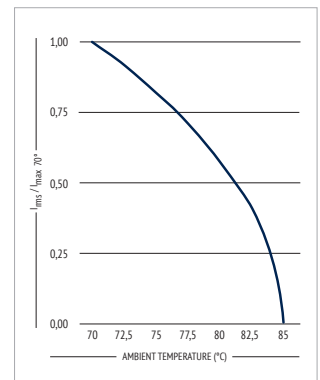

DC-LINK



## CAN STYLES

### CAN STYLE J/K

$H_1 = H + 5\text{mm}$

Aluminum/Plastic Case  
Anti-Creep Insulation

$D_t = 12\text{mm}$

M6\*10 screw female\*

\*preferred

in mm

## DIMENSIONS

Diameter D	Can Style	Pitch P	Length Cab Lc	Diameter Terminal $D_t$
$\pm 1,0\text{ mm}$		$\pm 0,5\text{mm}$	$\pm 1,0\text{ mm}$	$\pm 0,5\text{mm}$
76	J	32	10	12
86	J	32	10	12
86	K	32	32	12

Max. Torque for terminals: 3 Nm (M5), 5 Nm (M6), 6 Nm (M8), 8 Nm (M10)  
Max. Torque for stud mounting screws: 12 Nm (M12), 15Nm (M16)

DC-LINK

## ORDER CODE

FC	C	2S	DY	107	K	H	136	0	3	1	J	1	E 3
Capacitor type	Product shape	DC rated voltage code (V)	Series code	Capacitance Code Examples ( $\mu\text{F}$ )	Capacitance tolerance	Diameter (mm)	Height (mm)	Terminal style	Terminal pitch (mm)	Stud bolt mounting	Can style	Inner Construction	For internal use
Film Cap. = FC	cylindrical = C	600 <b>2S</b> 700 <b>2Q</b> 800 <b>2K</b> 900 <b>R2</b> 1000 <b>3A</b> 1100 <b>A3</b> 1200 <b>3B</b> 1500 <b>C3</b>	CBB131S DY	100 <b>107</b> 220 <b>227</b> 420 <b>427</b> 500 <b>507</b> 1000 <b>108</b> 1100 <b>118</b>	$\pm 5\%$ <b>J</b> $\pm 10\%$ <b>K</b> $\pm 20\%$ <b>M</b>	76 <b>H</b> 86 <b>L</b>	95 <b>095</b> 120 <b>120</b> 136 <b>136</b> 155 <b>155</b> 175 <b>175</b>	Female M5*7 <b>8</b> Female M6*10 <b>0</b> Female M8*10 <b>2</b> Female M8*12 <b>6</b> Female M10*10 <b>4</b> Female M10*12 <b>B</b> Male M6*20 <b>1</b> Male M8*12 <b>9</b> Male M8*15 <b>A</b> Male M8*17 <b>7</b> Male M8*20 <b>3</b> Male M10*20 <b>5</b>	32 <b>3</b>	flat, with Y bracket <b>Y</b> flat, without bracket <b>0</b> bolt M12x16 <b>1</b> bolt M16x25 <b>2</b> bolt M12x12 <b>3</b>	Style J <b>J</b> Style K <b>K</b>	<b>1</b> <b>2</b>	



### INTERNAL CONSTRUCTION

(Example: Can Style J, double inner construction)

NO.	ITEM	MATERIAL
1	Winding Core	PC
2	Metallized Film	PP + Al, Zn
3	Metal Sprayed Electrode	Zn + Sn/Zn
4	Terminals	Cu, Sn-plated
5	Deck	PC
6	Aluminum Case	Al
7	Potting Compound	PU resin (+Epoxy)
8	Connection Electrode	Cu
9	Insulation Cover	PP
10	Winding Insulation	Paper + PP

### ACCESSOIRES FOR BRACKET MOUNTING (ORDER CODE „Y“)

in mm

### MARKING

	BRAND
<b>CBB 131S</b>	SERIES DESIGNATION
540µF ±10%	CAPACITANCE AND TOLERANCE
<b>U<sub>R</sub> = 600V<sub>DC</sub> SH</b>	U <sub>R</sub> RATED VOLTAGE
<b>U<sub>TC</sub> = 3000V 50/60 HZ</b>	U <sub>TC</sub> VOLTAGE BETWEEN TERMINALS AND CASE, FREQUENCY
<b>-40~+85°C IEC61071</b>	TEMPERATURE RANGE, REFERENCE STANDARD
<b>Discharge before handling</b>	SAFETY WARNING
<b>JE37F26104</b>	DATE CODE

DC-LINK



**RATINGS**

U <sub>R</sub> ≤85°C (V <sub>DC</sub> )	C <sub>R</sub> (µF)	I <sub>max</sub>				f <sup>(1)</sup> (A)	ESR <sub>typ</sub> 20°C, 1kHz (mΩ)	R <sub>th</sub> <sup>(2)</sup> (K/W)	L <sub>s</sub> 20°C (nH)	D ±1,0 (mm)	H H1=H+5mm ±1,0 (mm)	ORDER CODE  *# to be defined, see ordering code table
		70°C, 1kHz (A)	60°C, 1kHz (A)	50°C, 1kHz (A)	≤40°C, 1kHz (A)							
<b>600 2S</b>	570	36	51	63	72	1600	1,5	5,1	≤50	76	95	FCC2SDY577#H095#3##2E3
	700	36	51	62	71	2100	1,4	5,6	≤50	86	95	FCC2SDY707#L095#3##2E3
	800	34	49	60	69	1650	1,8	4,7	≤60	76	120	FCC2SDY807#H120#3##2E3
	1000	45	65	70	70	3200	1,1	4,3	≤60	76	155	FCC2SDY108#H155#3##2E3
	1100	37	53	65	75	2300	1,5	4,8	≤60	86	120	FCC2SDY118#L120#3##2E3
	1200	46	66	70	70	2150	1,1	4,2	≤60	76	175	FCC2SDY128#H175#3##2E3
	1200	35	51	62	70	2150	1,7	4,6	≤60	86	136	FCC2SDY128#L136#3##2E3
	1300	36	52	63	70	2230	1,7	4,4	≤60	86	155	FCC2SDY138#L155#3##2E3
1600	48	68	70	70	4500	1,0	4,3	≤60	86	175	FCC2SDY168#L175#3##2E3	
<b>700 2Q</b>	500	35	50	61	70	1680	1,6	5,1	≤50	76	95	FCC2QDY507#H095#3##2E3
	660	36	51	62	71	2200	1,4	5,6	≤50	86	95	FCC2QDY667#L095#3##2E3
	700	32	46	56	65	1680	2,0	4,7	≤60	76	120	FCC2QDY707#H120#3##2E3
	850	31	45	55	64	1680	2,3	4,3	≤60	76	155	FCC2QDY857#H155#3##2E3
	900	35	50	61	70	3350	1,7	4,8	≤60	86	120	FCC2QDY907#L120#3##2E3
	1000	44	63	70	70	3200	1,2	4,2	≤60	76	175	FCC2QDY108#H175#3##2E3
	1100	34	49	60	70	2260	1,8	4,6	≤60	86	136	FCC2QDY118#L136#3##2E3
	1200	35	50	62	70	2350	1,8	4,4	≤60	86	155	FCC2QDY128#L155#3##1E3
	1400	48	68	70	70	4500	1,0	4,3	≤50	86	175	FCC2QDY148#L175#3##2E3
<b>800 2K</b>	350	34	48	59	68	1550	1,7	5,1	≤50	76	95	FCC2KDY357#H095#3##2E3
	490	35	49	60	69	2000	1,5	5,6	≤50	86	95	FCC2KDY497#L095#3##2E3
	500	31	45	55	64	1600	2,1	4,7	≤60	76	120	FCC2KDY507#H120#3##2E3
	600	31	44	54	62	1590	2,4	4,3	≤60	76	155	FCC2KDY607#H155#3##1E3
	650	34	48	59	68	3200	1,8	4,8	≤60	86	120	FCC2KDY657#L120#3##2E3
	730	44	63	70	70	3100	1,2	4,2	≤60	76	175	FCC2KDY737#H175#3##2E3
	770	33	48	59	68	2100	1,9	4,6	≤60	86	136	FCC2KDY777#L136#3##2E3
	780	33	48	58	67	2150	2,0	4,4	≤60	86	155	FCC2KDY787#L155#3##2E3
950	45	65	70	70	4130	1,1	4,3	≤60	86	175	FCC2KDY957#L175#3##2E3	
<b>900 R2</b>	350	34	48	59	68	1500	1,7	5,1	≤50	76	95	FCCR2DY357#H095#3##2E3
	490	35	49	60	69	2000	1,5	5,6	≤50	86	95	FCCR2DY497#L095#3##2E3
	500	31	45	55	64	1600	2,1	4,7	≤60	76	120	FCCR2DY507#H120#3##2E3
	600	31	44	54	62	1580	2,4	4,3	≤60	76	155	FCCR2DY607#H155#3##2E3
	650	34	48	59	68	3100	1,8	4,8	≤60	86	120	FCCR2DY657#L120#3##2E3
	730	44	63	70	70	3200	1,2	4,2	≤60	76	175	FCCR2DY737#H175#3##2E3
	770	33	48	59	68	2100	1,9	4,6	≤60	86	136	FCCR2DY777#L136#3##2E3
	780	33	48	58	67	2150	2,0	4,4	≤60	86	155	FCCR2DY787#L155#3##2E3
	950	45	65	70	70	4150	1,1	4,3	≤60	86	175	FCCR2DY957#L175#3##2E3
<b>1000 3A</b>	300	32	45	56	64	1500	1,9	5,1	≤50	76	95	FCC3ADY307#H095#3##2E3
	400	31	44	54	62	1580	2,2	4,7	≤60	76	120	FCC3ADY407#H120#3##2E3
	400	33	47	58	67	1580	1,6	5,6	≤50	86	95	FCC3ADY407#L095#3##2E3
	490	29	42	52	60	1600	2,6	4,3	≤60	76	155	FCC3ADY497#H155#3##2E3
	540	33	47	57	66	2000	1,9	4,8	≤60	86	120	FCC3ADY547#L120#3##2E3
	590	42	61	70	70	3000	1,3	4,2	≤60	76	175	FCC3ADY597#H175#3##2E3
	600	32	47	57	66	3120	2,0	4,6	≤60	86	136	FCC3ADY607#L136#3##2E3
	640	32	47	57	66	3250	2,1	4,4	≤60	86	155	FCC3ADY647#L155#3##2E3
	780	45	65	70	70	4000	1,1	4,3	≤60	86	175	FCC3ADY787#L175#3##2E3
<b>1100 A3</b>	220	31	44	54	63	1550	2,0	5,1	≤50	76	95	FCCA3DY227#H095#3##2E3
	300	29	41	51	58	1600	2,5	4,7	≤60	76	120	FCCA3DY307#H120#3##2E3
	300	32	46	56	65	1600	1,7	5,6	≤50	86	95	FCCA3DY307#L095#3##2E3
	350	27	39	48	56	1650	3,0	4,3	≤60	76	155	FCCA3DY357#H155#3##2E3
	400	31	45	55	63	3100	2,1	4,8	≤60	86	120	FCCA3DY407#L120#3##2E3
	430	30	43	52	60	3250	2,4	4,6	≤60	86	136	FCCA3DY437#L136#3##2E3
	440	41	58	70	70	3280	1,4	4,2	≤60	76	175	FCCA3DY447#H175#3##2E3
	500	43	62	70	70	3940	1,2	4,4	≤60	86	155	FCCA3DY507#L155#3##2E3
	580	44	62	70	70	3980	1,2	4,3	≤60	86	175	FCCA3DY587#L175#3##2E3

(1) Maximum permissible peak current, (2) Thermal resistance from hotspot to ambient (free convection)

>>

DC-LINK



U <sub>R</sub> ≤85°C (V <sub>DC</sub> )	C <sub>R</sub> (μF)	I <sub>max</sub>				İ <sup>(1)</sup> (A)	ESR <sub>top</sub> 20°C, 1kHz (mΩ)	R <sub>th</sub> <sup>(2)</sup> (K/W)	L <sub>s</sub> 20°C (nH)	D ±1,0 (mm)	H H1-H+5mm ±1,0 (mm)	ORDER CODE  *# to be defined, see ordering code table
		70°C, 1kHz (A)	60°C, 1kHz (A)	50°C, 1kHz (A)	≤40°C, 1kHz (A)							
<b>1200 3B</b>	180	31	43	53	61	1520	2,1	5,1	≤60	76	95	FCC3BDY187#H095#3##2E3
	250	27	39	48	55	1980	2,8	4,7	≤60	76	120	FCC3BDY257#H120#3##2E3
	250	31	45	55	63	1980	1,8	5,6	≤50	86	95	FCC3BDY257#L095#3##2E3
	330	42	59	70	70	2130	1,3	4,3	≤60	76	155	FCC3BDY337#H155#3##2E3
	370	41	58	70	70	2590	1,4	4,2	≤60	76	175	FCC3BDY377#H175#3##2E3
	380	29	42	51	59	2600	2,5	4,6	≤60	86	136	FCC3BDY387#L136#3##2E3
	400	29	42	51	59	2800	2,6	4,4	≤60	86	155	FCC3BDY407#L155#3##2E3
	480	42	60	70	70	3190	1,3	4,3	≤60	86	175	FCC3BDY487#L175#3##2E3
<b>1500 C3</b>	110	27	39	48	55	1340	2,6	5,1	≤50	76	95	FCCC3DY117#H095#3##2E3
	140	28	40	49	57	1360	2,2	5,6	≤50	86	95	FCCC3DY147#L095#3##2E3
	150	25	36	44	51	1420	3,3	4,7	≤60	76	120	FCCC3DY157#H120#3##2E3
	160	24	34	42	48	1450	4,0	4,3	≤60	76	155	FCCC3DY167#H155#3##2E3
	180	28	39	48	56	1560	2,7	4,8	≤60	86	120	FCCC3DY187#L120#3##2E3
	200	37	53	65	70	2200	1,7	4,2	≤60	76	175	FCCC3DY207#H175#3##2E3
	220	26	37	46	53	2460	3,1	4,6	≤60	86	136	FCCC3DY227#L136#3##2E3
	240	40	57	70	70	2590	1,4	4,4	≤60	86	155	FCCC3DY247#L155#3##2E3
	270	39	56	68	70	3100	1,5	4,3	≤60	86	175	FCCC3DY277#L175#3##2E3

(1) Maximum permissible peak current, (2) Thermal resistance from hotspot to ambient (free convection)

DC-LINK



FEATURES

- DC-Link
- 105°C
- Low ESR, high Currents
- Self-healing
- Long Lifetime
- Aluminum case

OVERVIEW

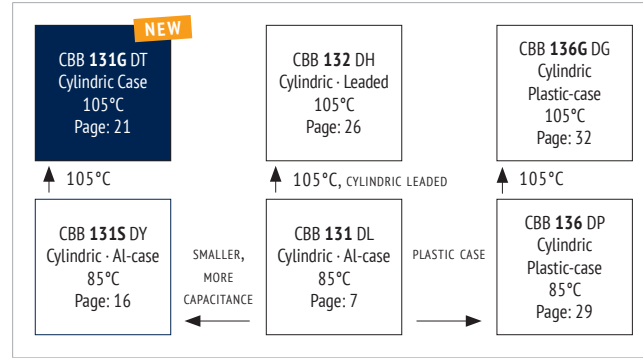

PRODUCT

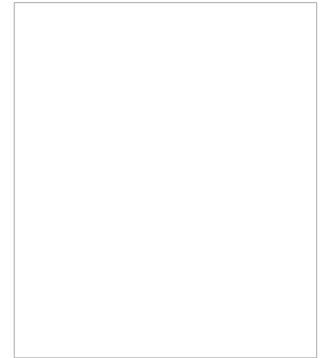

APPLICATIONS

- Photovoltaic and wind inverters
- Electric and hybrid electric vehicles
- Motion control, welding equipment, elevators
- High power frequency converters

CHARACTERISTICS

ITEM	CHARACTERISTICS
Climatic Category	40/85/56 (IEC 61071)
Operating Temperature	-40 ~ +105 °C ( $\Theta_{\text{hotspot}} \leq 105$ °C)
Storage Temperature	-40 ~ +85 °C
Rated Voltage $U_R$	600 ~ 1.600V <sub>DC</sub>
Capacitance Range	130 ~ 1.000 $\mu$ F
Capacitance Tolerance	$\pm 10$ % (K), $\pm 5$ % (J)
Voltage between Terminals $U_{TT}$	$1,5 \cdot U_{RDC}$ (20 °C, 10 s)
Voltage between Terminals & Case $U_{TC}$	$\geq 3.000V_{AC}$ (20°C, 50Hz, 10s)
Max. Overvoltage	Please see IEC 61071
Insulation Resistance $R_i \cdot C$	$\geq 10.000 M\Omega \cdot \mu F$ (20 °C, 100 V <sub>DC</sub> , 1 min)
Dielectric Dissipation Factor $\tan \delta_o$	$\leq 2 \cdot 10^{-4}$ (20 °C, 100 Hz)
Life Time Expectancy	$\geq 100.000h$ , failure rate $\leq 100$ FIT ( $\Theta_{\text{hotspot}} \leq 70^\circ C, U_{RDC}$ )
Reference Standard	IEC 61071:2007

ENVIRONMENTAL

The products are RoHS, WEEE and REACH compliant.  
The detailed version please see separate "Environmental Certificates" document or [www.jianghai-europe.com](http://www.jianghai-europe.com)

APPROVALS

**UL94-V0:**  
Plastic & Compound Mass

LIFETIME

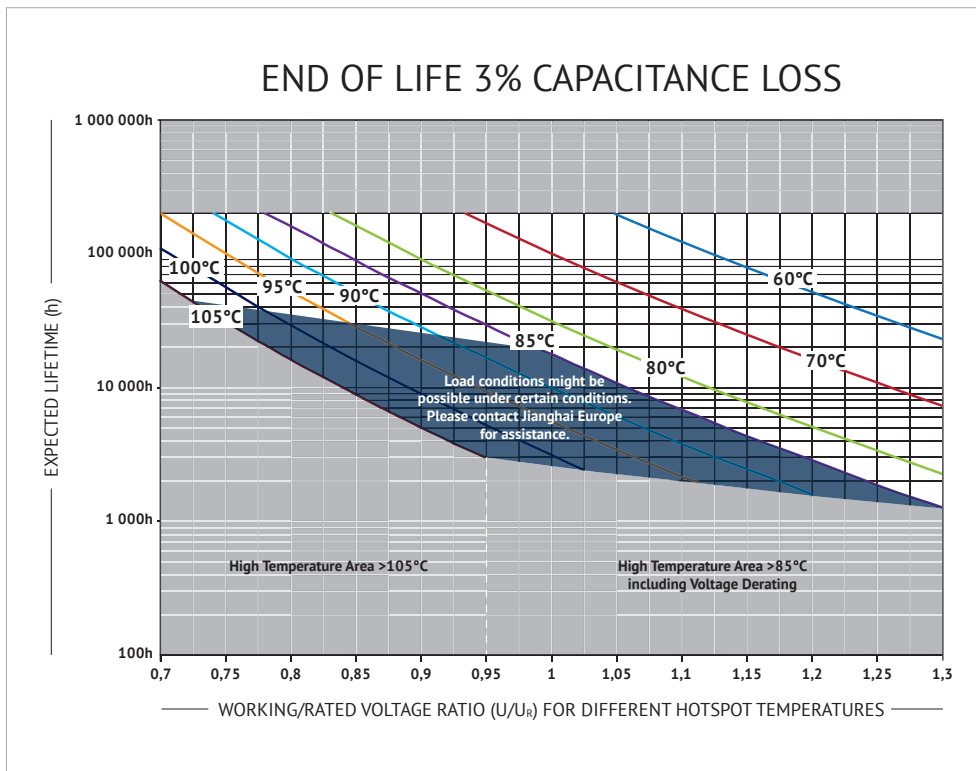

CURRENT DERATING

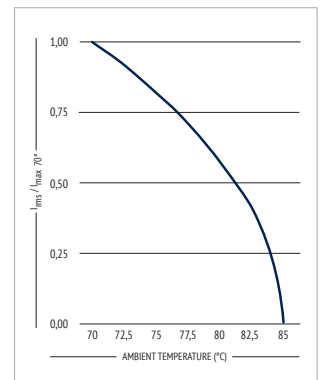

VOLTAGE DERATING

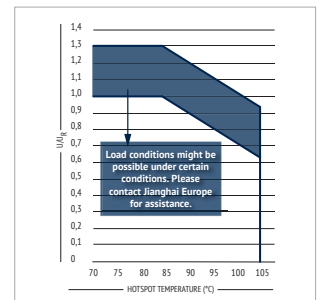

DC-LINK



■ CAN STYLES

**CAN STYLE B** UPDATED

Aluminum Case with Flanging  
Anti-Creep Insulation

$D_T = 12\text{mm}^*$

M6\*10 screw female\*

\*preferred

in mm

■ DIMENSIONS

Diameter D	Can Style	Pitch P	Length Cab Lc	Diameter Terminal $D_T$
$\pm 1,0\text{ mm}$		$\pm 0,5\text{mm}$	$\pm 1,0\text{ mm}$	$\pm 0,5\text{mm}$
76	B	32	32	12
86	B	32	32	12

Max. Torque for terminals: 3 Nm (M5), 5 Nm (M6), 6 Nm (M8), 8 Nm (M10)  
Max. Torque for stud mounting screws: 12 Nm (M12), 15Nm (M16)

Other Can Styles on request.

DC-LINK

■ ORDER CODE

FC	C	2S	DY	107	K	H	136	0	3	1	J	1	E 3
Capacitor type	Product shape	DC rated voltage code (V)	Series code	Capacitance Code Examples ( $\mu\text{F}$ )	Capacitance tolerance	Diameter (mm)	Height (mm)	Terminal style	Terminal pitch (mm)	Stud bolt mounting	Can style	Inner Construction	For internal use
Film Cap. = FC	cylindrical = C	600 <b>2S</b> 700 <b>2Q</b> 800 <b>2K</b> 900 <b>R2</b> 1000 <b>3A</b> 1100 <b>A3</b> 1200 <b>3B</b> 1400 <b>03</b> 1600 <b>3C</b>	CBB131G DT	100 <b>107</b> 220 <b>227</b> 420 <b>427</b> 500 <b>507</b> 1000 <b>108</b> 1100 <b>118</b>	$\pm 5\%$ <b>J</b> $\pm 10\%$ <b>K</b> $\pm 20\%$ <b>M</b>	76 <b>H</b> 86 <b>L</b>	95 <b>095</b> 120 <b>120</b> 136 <b>136</b> 155 <b>155</b> 175 <b>175</b>	Female M5*7 <b>8</b> Female M6*10 <b>0</b> Female M8*10 <b>2</b> Female M8*12 <b>6</b> Female M10*10 <b>4</b> Female M10*12 <b>B</b> Male M6*20 <b>1</b> Male M8*12 <b>9</b> Male M8*15 <b>A</b> Male M8*17 <b>7</b> Male M8*20 <b>3</b> Male M10*20 <b>5</b>	32 <b>3</b>	flat, with Y bracket <b>Y</b> flat, without bracket <b>0</b> bolt M12x16 <b>1</b> bolt M16x25 <b>2</b> bolt M12x12 <b>3</b>	Style B <b>B</b>	<b>1</b> <b>2</b>	



### INTERNAL CONSTRUCTION

(Example: Can Style J, double inner construction)

NO.	ITEM	MATERIAL
1	Winding Core	PC
2	Metallized Film	PP + Al, Zn
3	Metal Sprayed Electrode	Zn + Sn/Zn
4	Terminals	Cu, Sn-plated
5	Deck	PC
6	Aluminum Case	Al
7	Potting Compound	PU resin (+Epoxy)
8	Connection Electrode	Cu
9	Insulation Cover	PP
10	Winding Insulation	Paper + PP

### ACCESSOIRES FOR BRACKET MOUNTING (ORDER CODE „Y“)

in mm

### MARKING

	BRAND
<b>CBB 131G</b>	SERIES DESIGNATION
540µF ±10%	CAPACITANCE AND TOLERANCE
<b>U<sub>R</sub> = 600V<sub>DC</sub> SH</b>	U <sub>R</sub> RATED VOLTAGE
<b>U<sub>TC</sub> = 3000V 50/60 HZ</b>	U <sub>TC</sub> VOLTAGE BETWEEN TERMINALS AND CASE, FREQUENCY
<b>-40~+105°C IEC61071</b>	TEMPERATURE RANGE, REFERENCE STANDARD
<b>Discharge before handling</b>	SAFETY WARNING
<b>JE37F26104</b>	DATE CODE

DC-LINK





U <sub>r</sub> ≤85°C (V <sub>oc</sub> )	C <sub>r</sub> (μF)	I <sub>max</sub>			I <sup>(1)</sup> (A)	ESR <sub>typ</sub> 20°C, 1kHz (mΩ)	R <sub>th</sub> <sup>(2)</sup> (K/W)	L <sub>s</sub> 20°C (nH)	D ±1,0 (mm)	H H1=H+5mm ±1,0 (mm)	ORDER CODE
		70°C, 1kHz (A)	60°C, 1kHz (A)	≤50°C, 1kHz (A)							
600 2S	350	50	61	70	3600	1,6	5,1	≤60	76	95	FCC2SDT357#H095#3#BE3
	480	45	55	64	3840	2,1	4,7	≤60	76	120	FCC2SDT487#H120#3#BE3
	480	51	62	71	3840	1,4	5,6	≤60	86	95	FCC2SDT487#L095#3#BE3
	580	43	52	60	5800	2,4	4,6	≤60	76	136	FCC2SDT587#H136#3#BE3
	620	56	68	79	6200	1,5	4,3	≤60	76	155	FCC2SDT627#H155#3#BE3
	700	55	67	77	7200	1,6	4,2	≤60	76	175	FCC2SDT707#H175#3#BE3
	750	47	57	66	7200	2,0	4,6	≤60	86	136	FCC2SDT757#L136#3#BE3
950	56	68	79	9500	1,5	4,3	≤60	86	175	FCC2SDT957#L175#3#BE3	
700 2Q	280	48	59	68	2800	1,7	5,1	≤50	76	95	FCC2QDT287#H095#3#BE3
	370	49	60	69	3700	1,5	5,6	≤50	86	95	FCC2QDT377#L095#3#BE3
	380	44	54	62	3800	2,2	4,7	≤60	76	120	FCC2QDT387#H120#3#BE3
	430	41	50	58	4300	2,6	4,6	≤60	76	136	FCC2QDT437#H136#3#BE3
	470	54	66	76	4700	1,6	4,3	≤60	76	155	FCC2QDT477#H155#3#BE3
	510	48	59	68	5100	1,8	4,8	≤60	86	120	FCC2QDT517#L120#3#BE3
	560	53	65	75	5600	1,7	4,2	≤60	76	175	FCC2QDT567#H175#3#BE3
	580	47	57	65	5800	2,0	4,6	≤60	86	136	FCC2QDT587#L136#3#BE3
	640	55	67	77	6400	1,5	4,4	≤50	86	155	FCC2QDT647#L155#3#BE3
	750	54	66	76	7500	1,6	4,3	≤60	86	175	FCC2QDT757#L175#3#BE3
	1000	60	73	85	8000	1,4	4,0	≤60	86	225	FCC2QDT108#L225#3#BE3
800 2K	280	44	54	63	2800	2,0	5,1	≤50	76	95	FCC2KDT287#H095#3#BE3
	370	47	58	67	3700	1,6	5,6	≤50	86	95	FCC2KDT377#L095#3#BE3
	380	40	50	57	3800	2,6	4,7	≤60	76	120	FCC2KDT387#H120#3#BE3
	430	39	47	55	4300	2,9	4,6	≤60	76	136	FCC2KDT437#H136#3#BE3
	470	52	64	74	4700	1,7	4,3	≤60	76	155	FCC2KDT477#H155#3#BE3
	510	44	54	62	5100	2,1	4,8	≤60	86	120	FCC2KDT517#L120#3#BE3
	560	49	60	69	5600	2,0	4,2	≤60	76	175	FCC2KDT567#H175#3#BE3
	580	44	54	62	5800	2,2	4,6	≤60	86	136	FCC2KDT587#L136#3#BE3
	640	55	67	77	6400	1,5	4,4	≤50	86	155	FCC2KDT647#L155#3#BE3
	750	53	66	76	7500	1,6	4,3	≤60	86	175	FCC2KDT757#L175#3#BE3
	1000	58	71	82	8000	1,5	4,0	≤60	86	225	FCC2KDT108#L225#3#BE3
900 R2	220	40	50	57	2420	2,4	5,1	≤50	76	95	FCCR2DT227#H095#3#BE3
	290	44	54	62	3190	1,8	5,6	≤50	86	95	FCCR2DT297#L095#3#BE3
	300	38	46	54	3300	2,9	4,7	≤60	76	120	FCCR2DT307#H120#3#BE3
	330	36	44	51	3630	3,3	4,6	≤60	76	136	FCCR2DT337#H136#3#BE3
	360	49	60	69	3960	1,9	4,3	≤60	76	155	FCCR2DT367#H155#3#BE3
	400	42	52	60	4400	2,3	4,8	≤60	86	120	FCCR2DT407#L120#3#BE3
	420	49	60	69	4620	2,0	4,2	≤60	76	175	FCCR2DT427#H175#3#BE3
	450	46	56	64	4950	2,1	4,6	≤60	86	136	FCCR2DT457#L136#3#BE3
	500	53	65	75	5000	1,6	4,4	≤50	86	155	FCCR2DT507#L155#3#BE3
	560	52	64	73	5600	1,7	4,3	≤60	86	175	FCCR2DT567#L175#3#BE3
	810	65	79	91	8100	1,6	3,0	≤60	86	225	FCCR2DT817#L225#3#BE3
1000 3A	170	38	47	54	2040	2,7	5,1	≤50	76	95	FCC3ADT177#H095#3#BE3
	240	37	45	52	2880	3,1	4,7	≤60	76	120	FCC3ADT247#H120#3#BE3
	240	43	53	61	2880	1,9	5,6	≤50	86	95	FCC3ADT247#L095#3#BE3
	270	36	44	51	3240	3,4	4,6	≤60	76	136	FCC3ADT277#H136#3#BE3
	300	48	59	68	3600	2,0	4,3	≤60	76	155	FCC3ADT307#H155#3#BE3
	320	41	51	58	3840	2,4	4,8	≤60	86	120	FCC3ADT327#L120#3#BE3
	350	46	56	64	4200	2,3	4,2	≤60	76	175	FCC3ADT357#H175#3#BE3
	420	43	52	60	5040	2,4	4,6	≤60	86	136	FCC3ADT427#L136#3#BE3
	420	57	70	81	5040	1,4	4,4	≤50	86	155	FCC3ADT427#L155#3#BE3
	480	50	62	71	5760	1,8	4,3	≤60	86	175	FCC3ADT487#L175#3#BE3
	650	53	65	75	6500	1,8	4,0	≤60	86	225	FCC3ADT657#L225#3#BE3

DC-LINK

(1) Maximum permissible peak current, (2) Thermal resistance from hotspot to ambient (free convection)

>>



U <sub>R</sub> ≤85°C (V <sub>DC</sub> )	C <sub>R</sub> (μF)	I <sub>max</sub>			î <sup>(1)</sup> (A)	ESR <sub>typ</sub> 20°C, 1kHz (mΩ)	R <sub>th</sub> <sup>(2)</sup> (K/W)	L <sub>s</sub> 20°C (nH)	D ±1,0 (mm)	H H1=H+5mm ±1,0 (mm)	ORDER CODE
		70°C, 1kHz (A)	60°C, 1kHz (A)	≤50°C, 1kHz (A)							
<b>1100 A3</b>	140	36	44	51	1680	3,0	5,1	≤50	76	95	FCCA3DT147#H095#3#BE3
	190	41	51	58	2280	2,1	5,6	≤50	86	95	FCCA3DT197#L095#3#BE3
	200	35	43	50	2400	3,4	4,7	≤50	76	120	FCCA3DT207#H120#3#BE3
	220	34	42	48	2640	3,7	4,6	≤60	76	136	FCCA3DT227#H136#3#BE3
	240	46	56	65	2880	2,2	4,3	≤60	76	155	FCCA3DT247#H155#3#BE3
	260	39	48	55	3120	2,7	4,8	≤60	86	120	FCCA3DT267#L120#3#BE3
	280	44	53	62	3360	2,5	4,2	≤60	76	175	FCCA3DT287#H175#3#BE3
	300	41	50	58	3600	2,6	4,6	≤60	86	136	FCCA3DT307#L136#3#BE3
	330	50	61	71	3960	1,8	4,4	≤50	86	155	FCCA3DT337#L155#3#BE3
	380	51	62	72	4560	1,8	4,3	≤60	86	175	FCCA3DT387#L175#3#BE3
540	50	61	71	5940	2,0	4,0	≤60	86	225	FCCA3DT547#L225#3#BE3	
<b>1200 3B</b>	120	34	42	49	1440	3,3	5,1	≤50	76	95	FCC3BDT127#H095#3#BE3
	160	34	42	48	1920	3,7	4,7	≤60	76	120	FCC3BDT167#H120#3#BE3
	160	39	48	56	1920	2,3	5,6	≤50	86	95	FCC3BDT167#L095#3#BE3
	180	33	40	46	2160	4,1	4,6	≤60	76	136	FCC3BDT187#H136#3#BE3
	210	44	54	62	2520	2,4	4,3	≤60	76	155	FCC3BDT217#H155#3#BE3
	220	40	49	57	2640	2,6	4,8	≤60	86	120	FCC3BDT227#L120#3#BE3
	240	41	51	58	2880	2,8	4,2	≤60	76	175	FCC3BDT247#H175#3#BE3
	250	39	47	55	3000	2,9	4,6	≤60	86	136	FCC3BDT257#L136#3#BE3
	280	52	63	73	3360	1,7	4,4	≤50	86	155	FCC3BDT287#L155#3#BE3
	320	49	61	70	3840	1,9	4,3	≤60	86	175	FCC3BDT327#L175#3#BE3
450	48	58	67	5400	2,2	4,0	≤60	86	225	FCC3BDT457#L225#3#BE3	
<b>1400 03</b>	170	35	43	50	2040	3,3	4,8	≤60	86	120	FCC03DT177#L120#3#BE3
	210	48	58	67	2520	2,0	4,4	≤60	86	155	FCC03DT217#L155#3#BE3
	330	45	55	63	3960	2,5	4,0	≤60	86	225	FCC03DT337#L225#3#BE3
<b>1600 3C</b>	130	35	42	49	1560	3,5	4,8	≤60	86	120	FCC3CDT137#L120#3#BE3
	160	44	54	63	1920	2,3	4,4	≤60	86	155	FCC3CDT167#L155#3#BE3
	250	42	51	59	3000	2,9	4,0	≤60	86	225	FCC3CDT257#L225#3#BE3

(1) Maximum permissible peak current, (2) Thermal resistance from hotspot to ambient (free convection)

DC-LINK

## FEATURES

- DC-Link
- 105°C Type
- High ripple current capability
- Self-healing
- Long lifetime
- Plastic case
- Soldering Style

## OVERVIEW

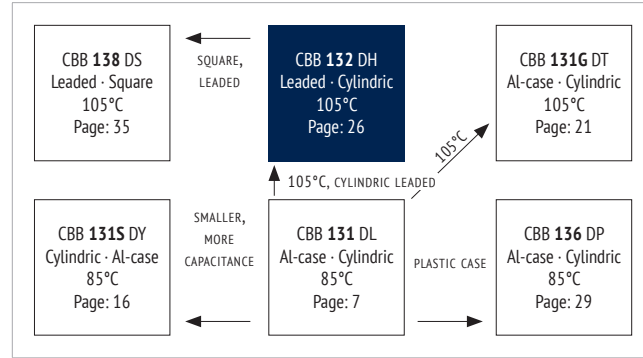

## PRODUCT



## APPLICATIONS

- High power frequency converters
- Motion control, welding equipment, elevators
- Photovoltaic and wind inverters

## CHARACTERISTICS

ITEM	CHARACTERISTICS
Climatic Category	40/105/56 (IEC 61071)
Operating Temperature	-40 ~ +105 °C ( $\Theta_{hotspot} \leq 105$ °C) $\Theta_{hotspot} = 85-105$ °C: See Voltage Derating Diagram
Storage Temperature	-40 ~ +105 °C
Rated Voltage $U_{RDC}$	600 ~ 1.200 $V_{DC}$
Capacitance Range	25 ~ 145 $\mu F$
Capacitance Tolerance	$\pm 10$ % (K), $\pm 5$ % (J)
Voltage between Terminals $U_{TT}$	$1,5 \cdot U_{RDC}$ (20°C, 10s)
Voltage between Terminals & Case $U_{TC}$	$\geq 3.000 V_{AC}$ (20°C, 50 Hz, 10s)
Max. Overvoltage	Please see IEC 61071
Insulation Resistance $R_i$ °C	$\geq 5.000 M\Omega \cdot \mu F$ (20°C, 100 $V_{DC}$ , 1 min)
Dielectric Dissipation Factor $\tan \delta_o$	$\leq 2 \cdot 10^{-4}$ (20°C, 100 Hz)
Life Time Expectancy	$\geq 100.000h$ , failure rate $\leq 50 FIT$ ( $\Theta_{hotspot} \leq 70$ °C, $U_{RDC}$ )
Reference Standard	IEC 61071:2007

## ENVIRONMENTAL

The products are RoHS, WEEE and REACH compliant.

The detailed version please see separate "Environmental Certificates" document or [www.jianghai-europe.com](http://www.jianghai-europe.com)

## APPROVALS

- UL94-V0:**  
Plastic & Compound Mass
- UL810:**  
CZDS2.E227010 (Construction)

## LIFETIME

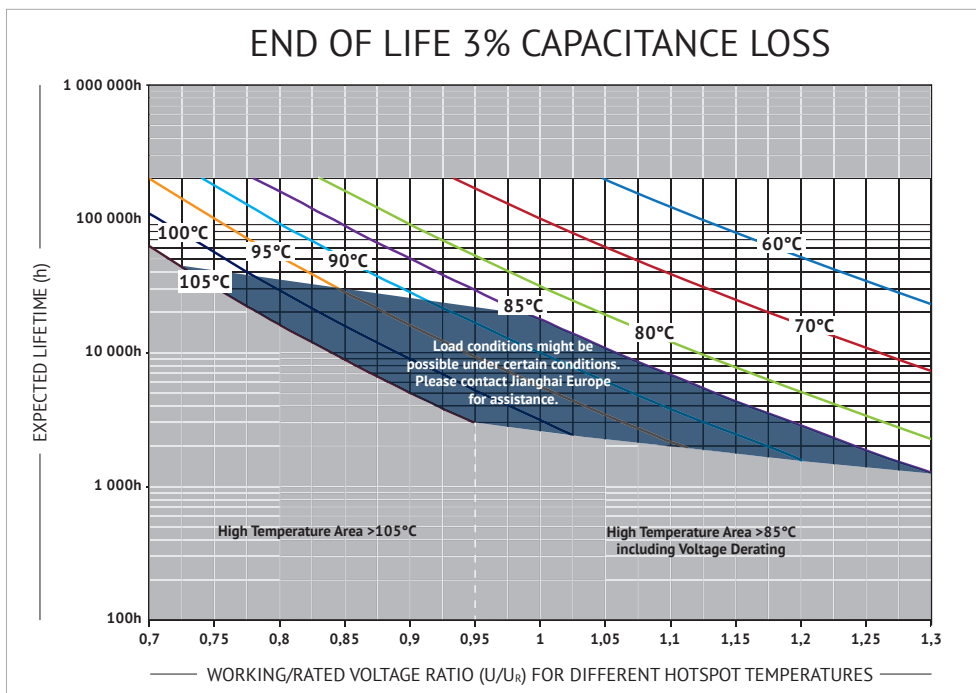

## CURRENT DERATING

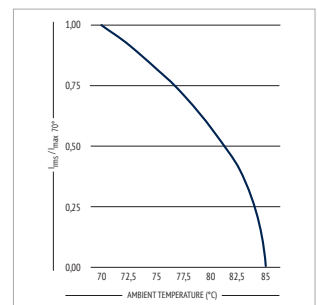

## VOLTAGE DERATING

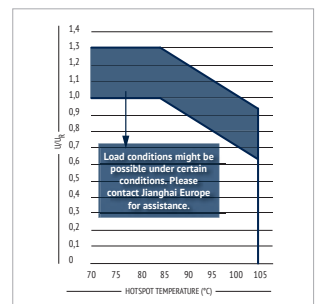

**DIMENSIONS**

**STYLE A**  
NO SOCKET,  
4 SOLDERING PINS

**STYLE B**  
WITH SOCKET,  
4 SOLDERING PINS  
W TYPICALLY 8MM+/-1MM  
L2 TYPICALLY 1,5MM+/-1MM

in mm

DC-LINK

**INTERNAL CONSTRUCTION**

NO.	ITEM	MATERIAL
1	Winding Core	PC
2	Metallized Film	PP + Al, Zn
3	Metal Sprayed Electrode	Zn + Sn/Zn
4	Terminals	Cu, Sn-plated
5	Potting Compound	Epoxy
6	Connection Electrode Case	Cu

**MARKING**

**CBB 132**  
60μF J 800V  
J02F12

BRAND  
PRODUCT SERIES  
CAPACITANCE, TOLERANCE AND RATED VOLTAGE  
DATE CODE



## ORDER CODE

FC	C	3A		DH	117		K		K		061	W	4		A		E 3	
Capacitor type	Product shape	DC rated voltage code (V)		Series code	Capacitance Code Examples (µF)		Capacitance tolerance		Diameter (mm)		Height L <sub>1</sub> (mm)	Terminal style P2	Bottom Bolt		Style		For internal use	
Film Cap. = FC	cylindrical = C	600	2S	CBB 132 = DH	50	506	±5%	J	50	D	59,0	059	12,7	W	M8*10	4	A	A
		800	2K		75	756	±10%	K	56,3	C	61,3	061			without	0	B	B
		1000	3A		80	806			63,5	E	70,6	071						
		1200	3B		110	117			35,9	X								
					120	127												
					145	157												
				200	207													
				220	227													

## RATINGS

U <sub>r</sub> ≤85°C (V <sub>DC</sub> )	C <sub>r</sub> (µF)	I <sub>max</sub>				İ <sup>(1)</sup> (A)	ESR <sub>typ</sub> 20°C, 1kHz (mΩ)	R <sub>th</sub> <sup>(2)</sup> (K/W)	dV/dt 20°C (V/µs)	D ±0,5 (mm)	L ±0,8 (mm)	L <sub>1</sub> ±1,3 (mm)	P <sub>1</sub> ±0,5 (mm)	P <sub>2</sub> ±0,5 (mm)	ORDER CODE
		70°C 10kHz (A)	60°C 10kHz (A)	50°C 10kHz (A)	≤40°C 10kHz (A)										
600 2S	30	12,4	17	21	24	847	8,0	8,1	28	35,9	53,7	61,3	5,4	12,7	FCC2SDH306#X061W##E3
	110	25	35	43	50	1650	3,5	4,6	15	50,0	63,0	70,6	5,1	12,7	FCCS2SDH117#D071W##E3
	145	35	49	60	70	2175	2,8	2,9	15	56,3	63,0	70,6	5,1	12,7	FCCS2SDH157#C071W##E3
	145	35	49	60	70	2900	2,5	3,3	20	63,5	51,4	59,0	5,1	12,7	FCCS2SDH157#E059W##E3
800 2K	60	16	22	27	32	900	5,0	7,8	15	50,0	63,0	70,6	5,1	12,7	FCC2KDH606#D071W##E3
	90	20	28	34	40	1350	4,0	6,3	15	56,3	63,0	70,6	5,1	12,7	FCC2KDH906#C071W##E3
	90	20	28	34	40	1800	3,0	8,3	20	63,5	51,4	59,0	5,1	12,7	FCC2KDH906#E059W##E3
1000 3A	45	15	21	25	30	675	6,0	7,4	15	50,0	63,0	70,6	5,1	12,7	FCCS3ADH456#D071W##E3
	60	18	25	31	36	900	5,0	6,2	15	56,3	63,0	70,6	5,1	12,7	FCCS3ADH606#C071W##E3
	60	18	25	31	36	1200	4,5	6,9	20	63,5	51,4	59,0	5,1	12,7	FCCS3ADH606#E059W##E3
1200 3B	25	10	14	17	20	500	8,9	11,2	20	50,0	63,0	70,6	5,1	12,7	FCCS3BDH256#D071W##E3
	35	15	21	25	30	700	6,0	7,4	20	56,3	63,0	70,6	5,1	12,7	FCCS3BDH356#C071W##E3
	35	15	21	25	30	875	5,5	8,1	25	63,5	51,4	59,0	5,1	12,7	FCCS3BDH356#E059W##E3

(1) Maximum permissible peak current, (2) Thermal resistance from hotspot to ambient (free convection)



## FEATURES

- DC-Link
- Very low dissipation factor
- High ripple current capability
- Self-healing
- Long lifetime
- Plastic case

## OVERVIEW

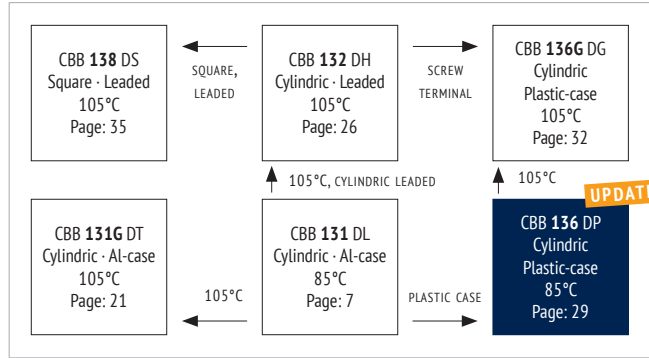

## PRODUCT



## APPLICATIONS

- High power frequency converters
- Motion control, welding equipment, elevators
- Photovoltaic and wind inverters

## CHARACTERISTICS

ITEM	CHARACTERISTICS
Climatic Category	40/85/56 (IEC 61071)
Operating Temperature	-40 ~ +85 °C ( $\theta_{\text{hotspot}} \leq 85$ °C)
Storage Temperature	-40 ~ +85 °C
Rated Voltage $U_{\text{RDC}}$	600 ~ 1.300 $V_{\text{DC}}$
Capacitance Range	60 ~ 645 $\mu\text{F}$
Capacitance Tolerance	$\pm 10$ % (K), $\pm 5$ % (J)
Voltage between Terminals $U_{\text{TT}}$	$1,5 \cdot U_{\text{RDC}}$ (20°C, 10 s)
Voltage between Terminals & Case $U_{\text{TC}}$	$\geq 3.000 V_{\text{AC}}$ (20°C, 50 Hz, 10 s)
Max. Overvoltage	Please see IEC 61071
Insulation Resistance $R_{\text{IC}}$	$\geq 5.000 \text{ M}\Omega \cdot \mu\text{F}$ (20°C, 100 $V_{\text{DC}}$ , 1 min)
Dielectric Dissipation Factor $\tan \delta_o$	$\leq 2 \cdot 10^{-4}$ (20°C, 100 Hz)
Life Time Expectancy	$\geq 100.000$ h, failure rate $\leq 50$ FIT ( $\theta_{\text{hotspot}} \leq 70^\circ\text{C}$ , $U_{\text{RDC}}$ )
Reference Standard	IEC 61071:2007

## ENVIRONMENTAL

The products are RoHS, WEEE and REACH compliant.

The detailed version please see separate "Environmental Certificates" document or [www.jianghai-europe.com](http://www.jianghai-europe.com)

## APPROVALS

### UL94-V0:

Plastic & Compound Mass

### UL810:

CZDS2.E227010 (Construction)

## LIFETIME

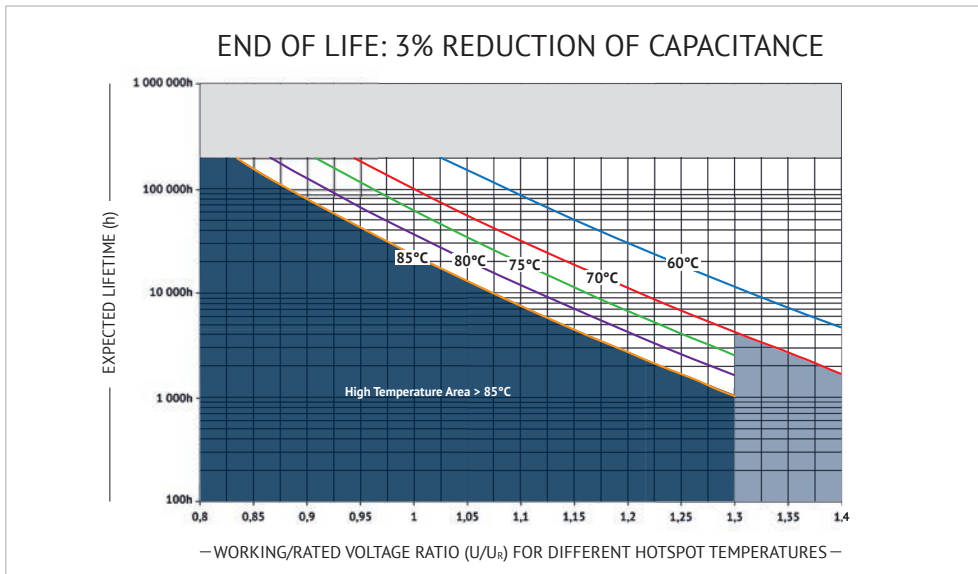

## CURRENT DERATING

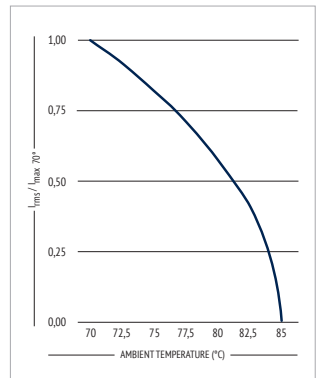

DC-LINK



**DIMENSIONS**

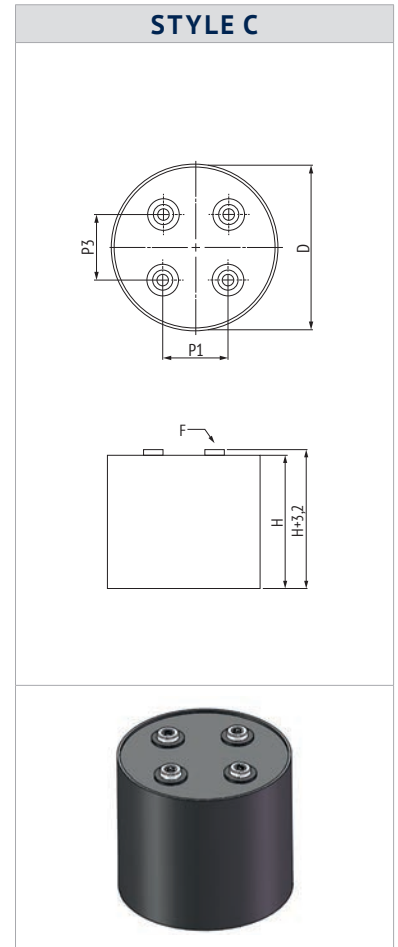
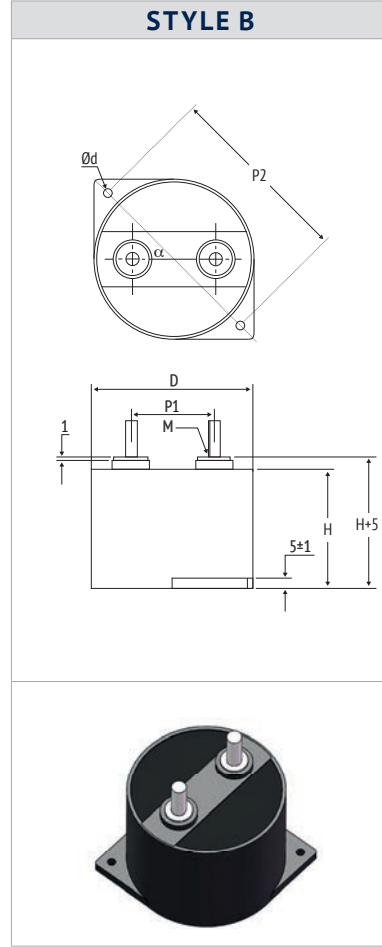
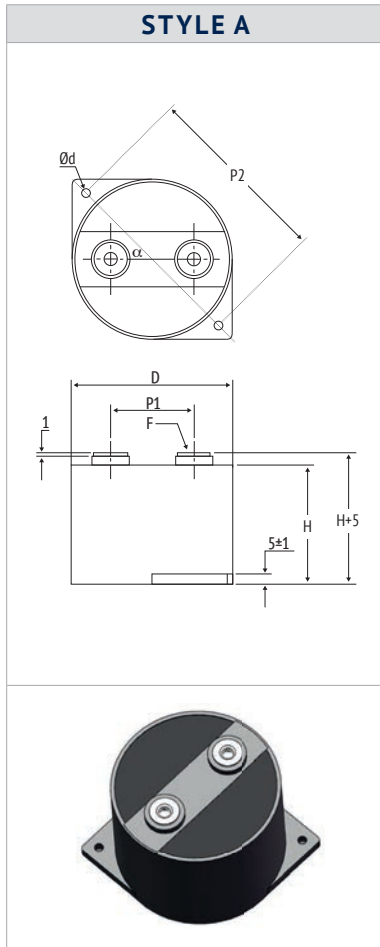

in mm

ØD±1 (mm)	H±1 (mm)	P1 ± 0.5 (mm)	P2 ± 0.5 (mm)	P3 ± 0.5 (mm)	Terminal (mm)		Ød ± 0.5 (mm)
					F Female	M Male	
84,5/85	51	45	101	-	M6*10 [order code 0]	M8*20 [order code 3]	5,5
84,5/85	65	45	101	-	M6*10 [order code 0]	M8*20 [order code 3]	5,5
95	83	38	-	38	M6*10 [order code 0]	-	-

α = 45°C +/- 2°

Max. torque for terminals: 5 Nm (M6), 8 Nm (M8)

Max. torque for mounting screws: 3,5 Nm

Other Terminals on request.

**INTERNAL CONSTRUCTION**

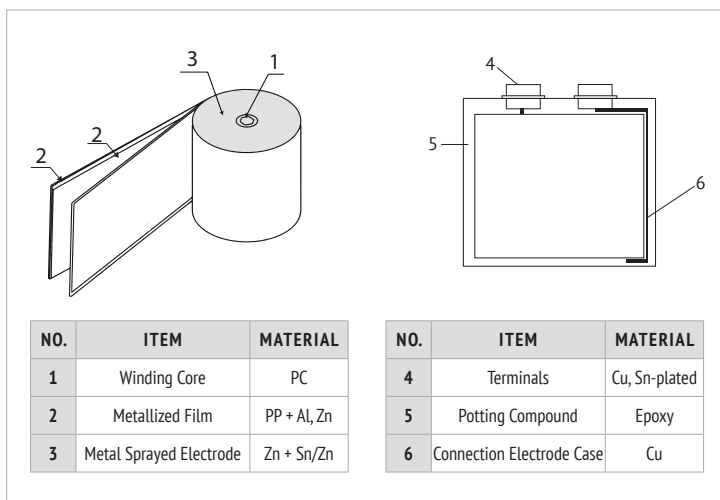

**MARKING**

BRAND

**CBB 136**

200µF ±10%

**U<sub>R</sub> = 600VDC**

**U<sub>TC</sub> = 3000V 50/60 HZ**

**-40~+85°C IEC61071**

**Discharge before handling**

E304F12104

DATE CODE

SERIES DESIGNATION

CAPACITANCE AND TOLERANCE

U<sub>R</sub> RATED VOLTAGE

U<sub>TC</sub> VOLTAGE BETWEEN TERMINALS AND CASE, FREQUENCY

TEMPERATURE RANGE, REFERENCE STANDARD

SAFETY WARNING



## ORDER CODE

FC	C	3A	DP	117	K	K	065	0	4	0	A	1E 3
Capacitor type	Product shape	DC rated voltage code (V)	Series code	Capacitance Code Examples (µF)	Capacitance tolerance	Diameter (mm)	Height (mm)	Terminal style	Terminal pitch P <sub>1</sub> (mm)	Fixed Hole	Style	For internal use
Film Cap. = FC	cylindrical = C	600 <b>2S</b> 800 <b>2K</b> 1000 <b>3A</b> 1100 <b>A3</b> 1200 <b>3B</b> 1300 <b>03</b>	CBB 136 = DP	50 <b>506</b> 75 <b>756</b> 80 <b>806</b> 110 <b>117</b> 120 <b>127</b> 200 <b>207</b> 220 <b>227</b> 280 <b>287</b>	±5% <b>J</b> ±10% <b>K</b>	84,5 <b>J</b> 85 <b>K</b> 95 <b>W</b>	51 <b>051</b> 65 <b>065</b> 83 <b>083</b>	Female M6*10 <b>0</b> Male M8*20 <b>3</b>	45 <b>4</b> 38 <b>3</b>	with <b>0</b> without <b>1</b>	Style A <b>A</b> Style B <b>B</b> Style C <b>C</b>	

## RATINGS

U <sub>R</sub> ≤85°C (V <sub>DC</sub> )	C <sub>R</sub> (µF)	I <sub>max</sub> 70°C, 1kHz (A)	60°C, 1kHz (A)	≤50°C, 1kHz (A)	I <sup>(1)</sup> (A)	ESR <sub>typ</sub> 20°C, 1kHz (mΩ)	R <sub>th</sub> <sup>(2)</sup> (K/W)	L <sub>s</sub> 20°C (nH)	D ±1,0 (mm)	H ±1,0 (mm)	ORDER CODE *#* to be defined, see ordering code table
<b>600 2S</b>	200	48	62	74	2100	1,2	5,3	≤30	85	51	FCC2SDP207#K051#40#1E3
	260	56	72	85	2193	0,9	5,3	≤32	84,5	51	FCC2SDP267#J051#40#1E3
	280	46	60	71	2100	1,4	5,0	≤40	84,5	65	FCC2SDP287#J065#40#1E3
		46	60	71	2100	1,4	5,0	≤40	85	65	FCC2SDP287#K065#40#1E3
	380	55	71	84	2135	1,0	5,0	≤40	84,5	65	FCC2SDP387#J065#40#1E3
	645	47	68	83	4000	0,84	5,2	≤25	95	83	FCC2SDP657#W083#31C1E3
<b>800 2K</b>	120	49	63	74	2100	1,2	5,3	≤32	85	51	FCC2KDP127#K051#40#1E3
	150	53	69	81	2174	1,0	5,3	≤32	84,5	51	FCC2KDP157#K051#40#1E3
		52	67	80	2100	1,1	5,0	≤40	84,5	65	FCC2KDP227#J065#40#1E3
	220	52	67	80	2100	1,1	5,0	≤40	85	65	FCC2KDP227#K065#40#1E3
<b>1000 3A</b>	75	45	58	69	1900	1,4	5,3	≤32	85	51	FCC3ADP756#K051#40#1E3
	100	47	60	71	1900	1,3	5,3	≤32	84,5	65	FCC3ADP107#J065#40#1E3
	110	42	54	64	1800	1,7	5,0	≤40	85	65	FCC3ADP117#K065#40#1E3
	140	45	58	68	1800	1,5	5,0	≤40	84,5	65	FCC3ADP147#J065#40#1E3
<b>1100 A3</b>	100	46	60	71	1936	1,3	5,3	≤32	84,5	51	FCCA3DP107#J051#40#1E3
	140	44	58	68	1805	1,5	5,0	≤40	84,5	65	FCCA3DP147#J065#40#1E3
<b>1200 3B</b>	60	38	49	57	1800	2,0	5,3	≤32	85	51	FCC3BDP606#K051#40#1E3
	70	45	58	69	1800	1,4	5,3	≤32	84,5	51	FCC3BDP706#J051#40#1E3
	90	37	48	56	1700	2,2	5,0	≤40	85	65	FCC3BDP906#K065#40#1E3
	100	41	53	62	1700	1,8	5,0	≤40	84,5	65	FCC3BDP107#J065#40#1E3
<b>1300 03</b>	70	45	58	68	1800	1,4	5,3	≤32	84,5	51	FCC03DP706#J051#40#1E3
	100	40	52	62	1700	1,8	5,0	≤40	84,5	65	FCC03DP107#J065#40#1E3

(1) Maximum permissible peak current, (2) Thermal resistance from hotspot to ambient (free convection)

DC-LINK





FEATURES

- DC-Link
- 105°C Type
- High ripple current capability
- Self-healing
- Long lifetime
- Plastic case

OVERVIEW

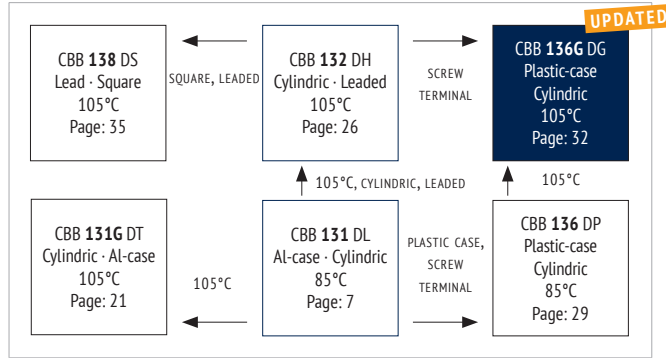

PRODUCT



APPLICATIONS

- High power frequency converters
- Motion control, welding equipment, elevators
- Photovoltaic and wind inverters

CHARACTERISTICS

ITEM	CHARACTERISTICS
Climatic Category	40/105/56 (IEC 61071)
Operating Temperature	-40 ~ +105 °C ( $\theta_{\text{hotspot}} \leq 105 \text{ °C}$ ) $\theta_{\text{hotspot}} = 85\text{-}105\text{ °C}$ : See Voltage Derating Diagram
Storage Temperature	-40 ~ +105 °C
Rated Voltage $U_{\text{RDC}}$	600 ~ 1 000 $V_{\text{DC}}$
Capacitance Range	55 ~ 220 $\mu\text{F}$
Capacitance Tolerance	$\pm 10 \%$ (K), $\pm 5 \%$ (J)
Voltage between Terminals $U_{\text{TT}}$	$1,5 \cdot U_{\text{RDC}}$ (20°C, 10s)
Voltage between Terminals & Case $U_{\text{TC}}$	$\geq 3.000 V_{\text{AC}}$ (20°C, 50 Hz, 10s)
Max. Overvoltage	Please see IEC 61071
Insulation Resistance $R_{\text{I}}^{\text{C}}$	$\geq 5.000 \text{ M}\Omega \cdot \mu\text{F}$ (20°C, 100 $V_{\text{DC}}$ , 1 min)
Dielectric Dissipation Factor $\tan \delta_0$	$\leq 2 \cdot 10^{-4}$ (20°C, 100 Hz)
Life Time Expectancy	$\geq 100.000 \text{ h}$ , failure rate $\leq 50 \text{ FIT}$ ( $\theta_{\text{hotspot}} \leq 70\text{ °C}$ , $U_{\text{RDC}}$ )
Reference Standard	IEC 61071:2007

ENVIRONMENTAL

The products are RoHS, WEEE and REACH compliant.

The detailed version please see separate "Environmental Certificates" document or [www.jianghai-europe.com](http://www.jianghai-europe.com)

APPROVALS

**UL94-V0:**  
Plastic & Compound Mass

LIFETIME

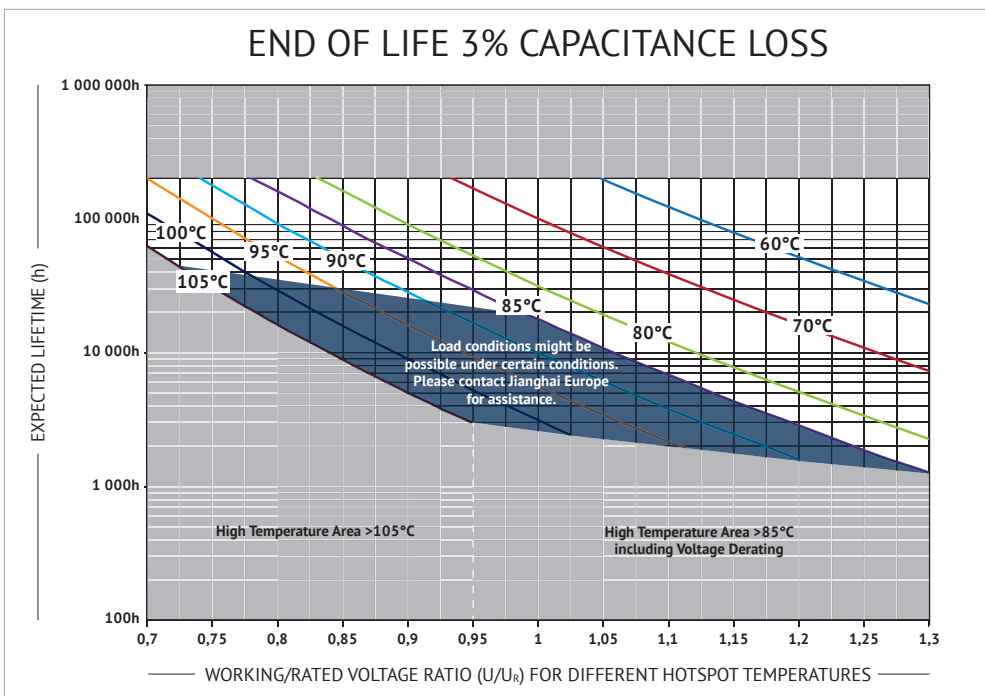

CURRENT DERATING

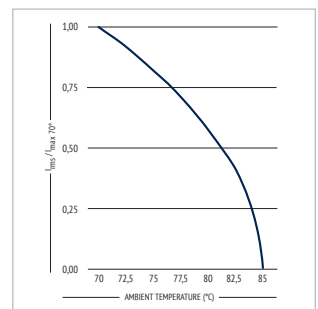

VOLTAGE DERATING

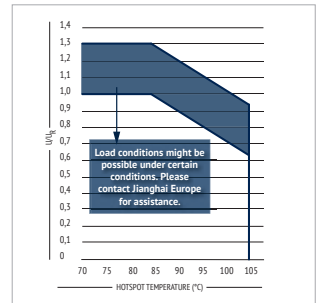

DC-LINK



**DIMENSIONS**

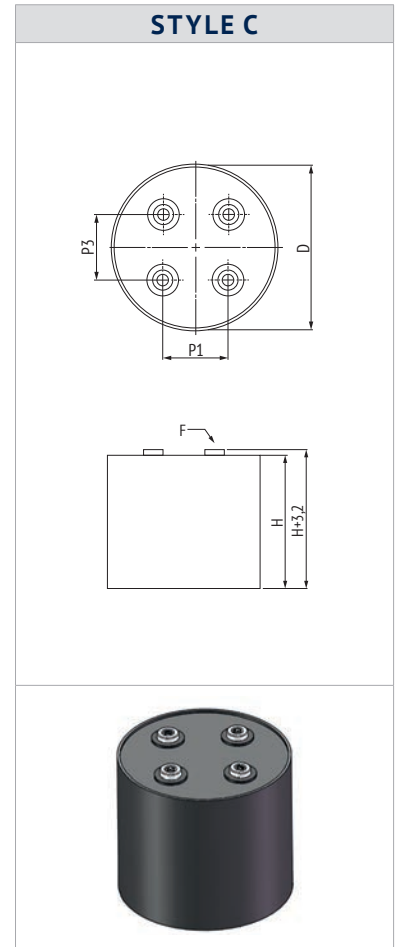
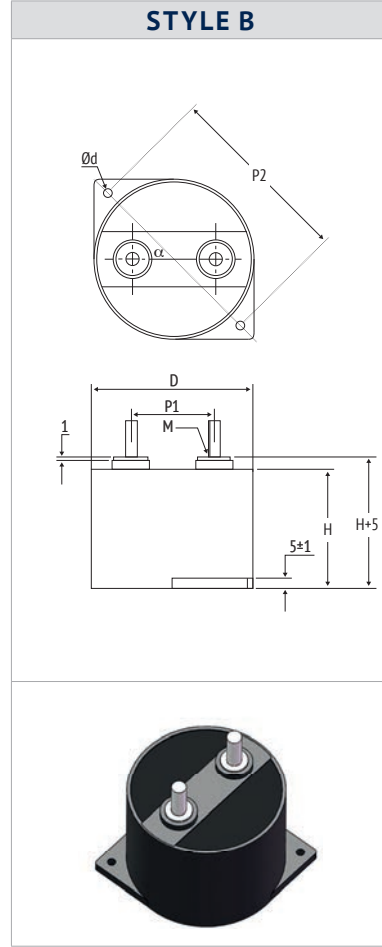
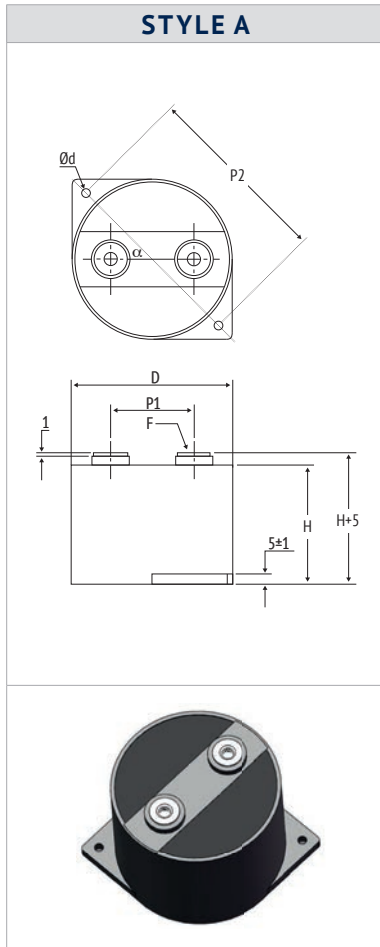

DC-LINK

in mm

ΦD±1 (mm)	H±1 (mm)	P1 ± 0.5 (mm)	P2 ± 0.5 (mm)	P3 ± 0.5 (mm)	Terminal (mm)		Φd ± 0.5 (mm)
					F Female	M Male	
84,5/85	51	45	101	-	M6*10 [order code 0]	M8*20 [order code 3]	5,5
84,5/85	65	45	101	-	M6*10 [order code 0]	M8*20 [order code 3]	5,5
95	83	38	-	38	M6*10 [order code 0]	-	-

α = 45°C +/- 2°

Max. torque for terminals: 5 Nm (M6), 8 Nm (M8)

Max. torque for mounting screws: 3,5 Nm

Other Terminals on request.

**INTERNAL CONSTRUCTION**

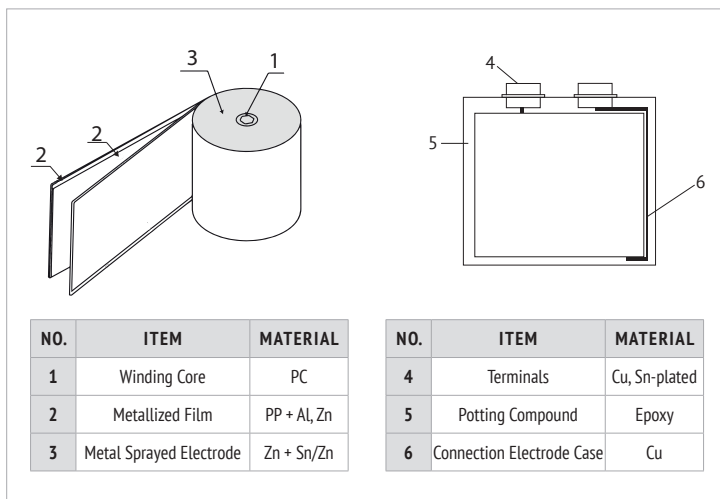

**MARKING**

**CBB 136G**  
200µF ±10%  
U<sub>R</sub> = 600VDC  
U<sub>TTC</sub> = 3000V 50/60 HZ  
-40~+85°C IEC61071

Discharge before handling  
E05F13104

BRAND	
SERIES DESIGNATION	
CAPACITANCE AND TOLERANCE	
U <sub>R</sub> RATED VOLTAGE	
U <sub>TTC</sub> VOLTAGE BETWEEN TERMINALS AND CASE, FREQUENCY	
TEMPERATURE RANGE, REFERENCE STANDARD	
SAFETY WARNING	
DATE CODE	



## ORDER CODE

FC	C	3A	DG	117	K	K	065	0	4	0	A	1E3
Capacitor type	Product shape	DC rated voltage code (V)	Series code	Capacitance Code Examples (μF)	Capacitance tolerance	Diameter (mm)	Height (mm)	Terminal style	Terminal pitch P <sub>1</sub> (mm)	Fixed hole	Style	For internal use
Film Cap. = FC	cylindrical = C	600 <b>2S</b> 800 <b>2K</b> 900 <b>R2</b> 1000 <b>3A</b>	CBB 136G = DG	50 <b>506</b> 75 <b>756</b> 80 <b>806</b> 110 <b>117</b> 120 <b>127</b> 200 <b>207</b> 220 <b>227</b> 280 <b>287</b>	±5% <b>J</b> ±10% <b>K</b>	84,5 <b>J</b> 85 <b>K</b> 95 <b>W</b>	51 <b>051</b> 65 <b>065</b>	Female M6*10 <b>0</b> Male M8*20 <b>3</b>	45 <b>4</b> 38 <b>3</b>	with <b>0</b> without <b>1</b>	Style A <b>A</b> Style B <b>B</b> Style C <b>C</b>	

## RATINGS

U <sub>R</sub> ≤85°C (V <sub>DC</sub> )	C <sub>R</sub> (μF)	I <sub>max</sub>				î <sup>(1)</sup> (A)	ESR <sub>typ</sub> 20°C, 1kHz (mΩ)	R <sub>th</sub> <sup>(2)</sup> (K/W)	L <sub>s</sub> 20°C (nH)	D ±1,0 (mm)	H ±1,0 (mm)	ORDER CODE  *#* to be defined, see ordering code table
		85°C, 1kHz (A)	70°C, 1kHz (A)	60°C, 1kHz (A)	≤50°C, 1kHz (A)							
<b>600 2S</b>	140	58	75	85	90	2000	1,1	5,3	≤32	85	51	FCC2SDG147#K051#4##1E3
	150	59	79	89	97	2240	1,0	5,3	≤32	84,5	51	FCC2SDG157#J051#4##1E3
	220	59	78	87	90	2100	1,1	5,0	≤40	84,5	65	FCC2SDG227#J065#4##1E3
<b>800 2K</b>	90	53	69	78	85	2000	1,3	5,3	≤32	85	51	FCC2KDG906#K051#4##1E3
	100	58	75	85	90	1998	1,1	5,3	≤32	84,5	51	FCC2KDG107#J051#4##1E3
	140	54	71	80	88	1800	1,3	5,0	≤40	84,5	65	FCC2KDG147#J065#4##1E3
<b>900 R2</b>	70	55	72	81	89	1688	1,2	5,3	≤32	84,5	51	FCCR2DG706#J051#4##1E3
	100	54	71	80	88	1570	1,3	5,0	≤40	84,5	65	FCCR2DG107#J065#4##1E3
<b>1000 3A</b>	55	49	64	72	79	1500	1,5	5,3	≤32	85	51	FCC3ADG556#K051#4##1E3
	85	48	62	70	76	1400	1,7	5,0	≤40	84,5	65	FCC3ADG856#J065#4##1E3

(1) Maximum permissible peak current, (2) Thermal resistance from hotspot to ambient (free convection)



## FEATURES

- DC-Link
- Design for DC Link Application
- Metal sprayed contacts for low ESR
- Self-healing

## OVERVIEW

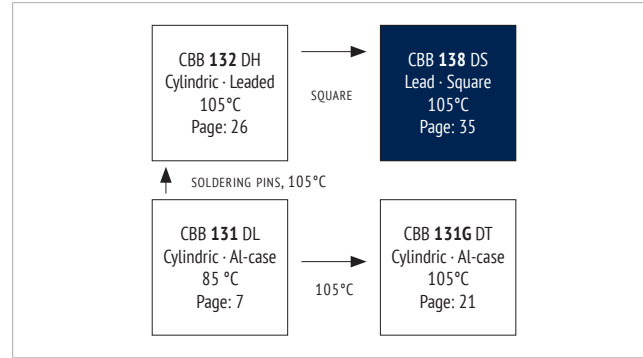

## PRODUCT



## APPLICATIONS

- Frequency inverter and intermediate circuits
- Industry high-end power supplies

## CHARACTERISTICS

ITEM	CHARACTERISTICS
Climatic Category	40/105/56 (IEC 61071)
Operating Temperature	-40 ~ +105 °C ( $\theta_{hotspot} \leq 105$ °C) $\theta_{hotspot} = 85-105$ °C: See Voltage Derating Diagram
Storage Temperature	-40 ~ +105 °C
Rated Voltage $U_{RDC}$	450 ~ 1.500 V <sub>DC</sub>
Capacitance Range	1 ~ 170 $\mu$ F
Capacitance Tolerance	$\pm 10$ % (K), $\pm 5$ % (J)
Voltage between Terminals $U_{TT}$	$1,5 \cdot U_{RDC}$ (20°C, 10s)
Voltage between Terminals & Case $U_{TC}$	$\geq 3.000$ V <sub>AC</sub> (20°C, 50 Hz, 10s)
Dielectric Dissipation Factor $\tan \delta_o$	$\leq 2 \cdot 10^{-4}$ (20 °C, 1 kHz)
Insulator Resistance $R_i$ , °C	$\geq 10.000$ M $\Omega \cdot \mu$ F (20 °C, 100 V <sub>DC</sub> , 1 min)
Max. Overvoltage	Please see IEC 61071
Life Time Expectancy	$\geq 100.000$ h, failure rate $\leq 50$ FIT (70°C)
Reference Standard	IEC 61071:2007

## ENVIRONMENTAL

The products are RoHS, WEEE and REAcH compliant.

The detailed version please see separate "Environmental Certificates" document or [www.jianghai-europe.com](http://www.jianghai-europe.com)

## APPROVALS

- UL94-V0:**
- Plastic & Compound Mass
- UL810:**
- CZDS2.E227010 (Construction)

## LIFETIME

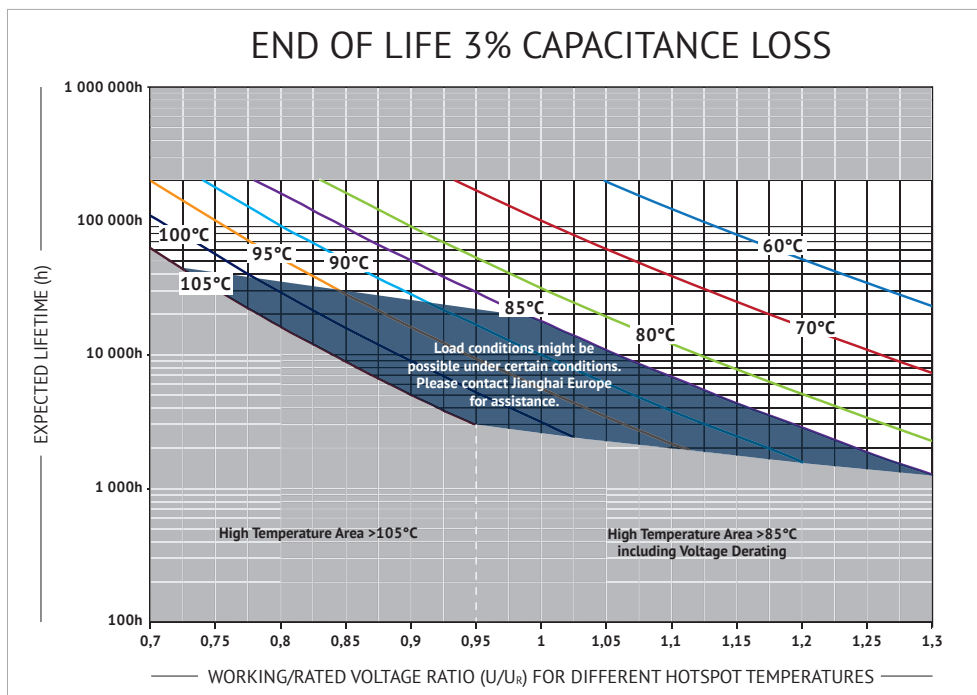

## CURRENT DERATING

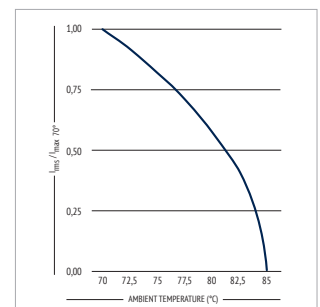

## VOLTAGE DERATING

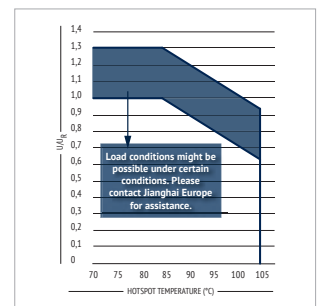

DC-LINK

## DIMENSIONS

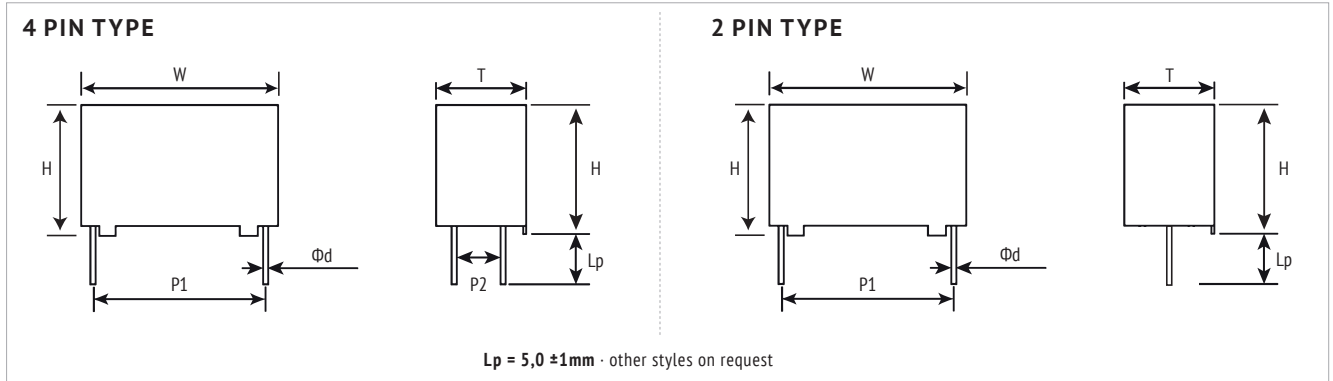

## INTERNAL CONSTRUCTION

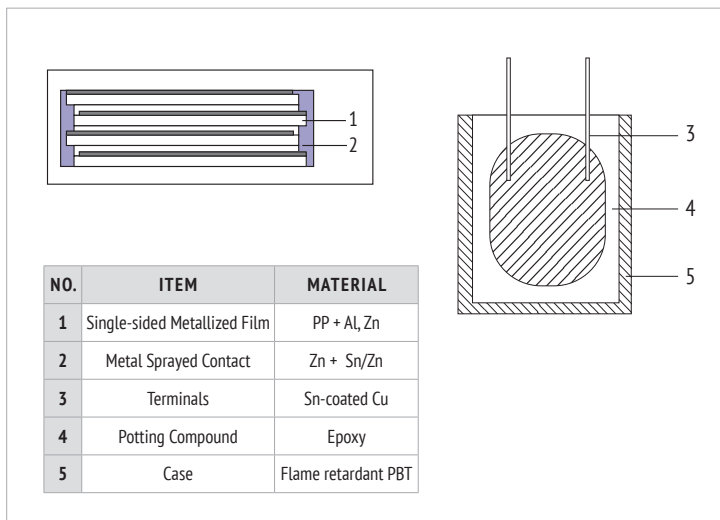

## MARKING

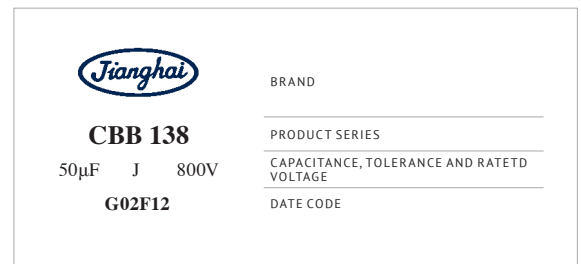

## HUMIDITY IMPROVEMENT

Capacitors in THB design are available on request.

## ORDER CODE

FC	S	3B	DS	105	K	A	FK	37	20	C	E 3
Capacitor type	Product shape	DC rated voltage code (V)	Series code	Capacitance Code (µF)	Capacitance tolerance	Pin Style (mm)	Dimension Code WxHxT (mm)	Pitch P <sub>1</sub> (mm)	Pitch P <sub>2</sub> (mm)	Leadwire Diameter Ød	For internal use
Film Cap. = FC	Square box = S	450 <b>2W</b> 500 <b>2H</b> 550 <b>2Y</b> 600 <b>2S</b> 700 <b>2Q</b> 800 <b>2K</b> 900 <b>R2</b> 1000 <b>3A</b> 1100 <b>A3</b> 1200 <b>3B</b> 1300 <b>03</b> 1500 <b>C3</b>	CBB 138 = DS	0,68 <b>684</b> 0,82 <b>824</b> 1,0 <b>105</b> 1,2 <b>125</b> 2,0 <b>205</b> 5,0 <b>505</b> 10 <b>106</b> 20 <b>206</b>	±5% <b>J</b> ±10% <b>K</b>	4 Pin Lp = 8mm <b>K</b> 4 Pin Lp = 5mm <b>A</b> 4 Pin Lp = 4,5mm <b>L</b> 4 Pin Lp = 4mm <b>S</b> 4 Pin Lp = 3,5mm <b>J</b> 2 Pin long leads (~ 20mm) <b>C</b> 2 Pin Lp = 5mm <b>B</b> 2 Pin Lp = 4,5mm <b>T</b> 2 Pin Lp = 4,0mm <b>M</b> 2 Pin Lp = 3,5mm <b>U</b> 2 Pin Lp = 3,2mm <b>V</b>	32 x 18 x 9 <b>I1</b> 32 x 20 x 11 <b>I4</b> 32 x 22 x 13 <b>I7</b> 32 x 28 x 14 <b>IC</b> 32 x 28 x 18 <b>ID</b> 32 x 33 x 18 <b>IF</b> 32 x 37 x 22 <b>II</b> 32 x 24,5 x 15 <b>IJ</b> 42,5 x 37 x 28 <b>F1</b> 42,5 x 40 x 20 <b>F2</b> 42,5 x 32 x 19 <b>F5</b> 42,5 x 44 x 24 <b>F9</b> 42,5 x 45 x 30 <b>FF</b> 42 x 42 x 28 <b>FH</b> 42,5 x 50 x 35 <b>FK</b> 42,5 x 18 x 24 <b>FL</b> 42,5 x 37 x 22 <b>FQ</b> 42,5 x 33,5 x 22 <b>FT</b> 57,5 x 60 x 35 <b>H6</b> 57,5 x 65 x 45 <b>H7</b> 57,5 x 70 x 35 <b>H8</b> 57,5 x 53 x 50 <b>HA</b> 57,5 x 45 x 30 <b>HH</b> 57,5 x 50 x 35 <b>HL</b> 57,5 x 55 x 45 <b>HS</b> 57,5 x 80 x 35 <b>K4</b> 57,5 x 65 x 35 <b>KA</b>	22,5 <b>22</b> 27,5 <b>27</b> 37,5 <b>37</b> 52,5 <b>52</b>	20,3 <b>20</b> 10,2 <b>10</b> - <b>00</b>	0,6 <b>A</b> 0,8 <b>B</b> 1,0 <b>C</b> 1,2 <b>D</b> 0,5 <b>E</b>	



**RATINGS**

U <sub>k</sub> ≤85°C (V <sub>oc</sub> )	C <sub>r</sub> (μF)	I <sub>max</sub>			ḟ <sup>(1)</sup> (A)	ESR <sub>typ</sub> 20°C 10kHz (mΩ)	R <sub>th</sub> <sup>(2)</sup> (K/W)	dV/dt 20°C (V/μs)	W +1/-1,5 (mm)	H +1/-1,5 (mm)	T +1/-1,5 (mm)	P <sub>1</sub> ±0,5 (mm)	P <sub>2</sub> ±0,5 (mm)	Ød ±0,05 (mm)	ORDER CODE *# to be defined, see ordering code table
		70°C 10kHz (A)	60°C 10kHz (A)	≤50°C 10kHz (A)											
450 2W	1	2,5	3,5	4,3	50	54,0	29,6	50	32	18	9	27,5	\	0,8	FCS2WDS105##I12700BE3
	2	3,0	4,2	5,1	100	34,0	32,7	50	32	18	9	27,5	\	0,8	FCS2WDS205##I12700BE3
	3	4,0	5,6	6,9	150	23,0	27,2	50	32	20	11	27,5	\	0,8	FCS2WDS305##I42700BE3
	4	4,0	5,6	6,9	200	20,5	30,5	50	32	20	11	27,5	\	0,8	FCS2WDS405##I42700BE3
	5	5,0	7,0	8,6	250	15,0	26,7	50	32	20	11	27,5	\	0,8	FCS2WDS505##I42700BE3
	5	5,5	7,7	9,5	250	14,0	23,6	50	32	22	13	27,5	\	0,8	FCS2WDS505##I72700BE3
	10	7,5	10,6	12,9	500	8,5	20,9	50	32	28	14	27,5	\	0,8	FCS2WDS106##IC2700BE3
	10	9,0	12,0	12,0	500	8,0	15,4	50	32	28	18	27,5	\	0,8	FCS2WDS106##ID2700BE3
	12	10,0	12,0	12,0	600	7,0	14,3	50	32	33	18	27,5	\	0,8	FCS2WDS126##IF2700BE3
	15	11,5	12,0	12,0	750	6,0	12,6	50	32	37	22	27,5	\	0,8	FCS2WDS156##II2700BE3
	15	9,5	13,4	15,0	450	8,5	13	30	42,5	18	24	37,5	\	1	FCS2WDS156##FL3700CE3
	18	11,0	12,0	12,0	900	6,0	13,8	50	32	37	22	27,5	\	0,8	FCS2WDS186##II2700BE3
	20	12,0	12,0	12,0	1000	5,0	12,8	50	32	37	22	27,5	\	0,8	FCS2WDS206##II2700BE3
	22	12,0	12,0	12,0	1100	5,0	12,8	50	32	37	22	27,5	\	0,8	FCS2WDS226##II2700BE3
	25	12,5	17,7	21,6	750	5,5	11,6	30	42,5	37	22	37,5	10,2	1	FCS2WDS256##FQ3710CE3
	30	12,0	16,9	20,7	900	6,0	11,6	30	42,5	40	20	37,5	10,2	1	FCS2WDS306##F23710CE3
	40	14,0	19,7	24,2	1200	5,5	9,3	30	42,5	37	28	37,5	10,2	1	FCS2WDS406##F13710CE3
	40	15,0	21,2	26,0	1200	5,2	8,5	30	42,5	44	24	37,5	10,2	1	FCS2WDS406##F93710CE3
	50	15,0	21,2	26,0	1500	4,0	11,1	30	42,5	45	30	37,5	20,3	1,2	FCS2WDS506##FF3720DE3
55	15,5	21,9	26,9	1650	5,0	8,3	30	57,5	45	30	37,5	20,3	1,2	FCS2WDS556##HH3720DE3	
60	16,5	23,2	28,5	1800	4,5	8,2	30	57,5	45	30	37,5	20,3	1,2	FCS2WDS606##HH3720DE3	
60	16,5	23,3	28,5	1800	4,0	9,2	30	42,5	45	30	37,5	20,3	1,2	FCS2WDS606##FF3720DE3	
80	16,0	22,5	27,6	1200	4,0	9,8	15	57,5	45	30	52,5	20,3	1,2	FCS2WDS806##HH5220DE3	
100	18,0	25,5	31,2	1500	3,8	8,1	15	57,5	50	35	52,5	20,3	1,2	FCS2WDS107##HL5220DE3	
130	22,0	31,1	36,0	1950	3,5	5,9	15	57,5	60	35	52,5	20,3	1,2	FCS2WDS137##H65220DE3	
140	24,0	33,9	36,0	2100	3,4	5,1	15	57,5	65	35	52,5	20,3	1,2	FCS2WDS147##KA5220DE3	
150	26,0	36,0	36,0	2250	3,2	4,6	15	57,5	70	35	52,5	20,3	1,2	FCS2WDS157##H85220DE3	
160	28,0	36,0	36,0	2400	3,1	4,1	15	57,5	80	35	52,5	20,3	1,2	FCS2WDS167##K45220DE3	
170	30,0	36,0	36,0	2550	3,0	3,7	15	57,5	80	35	52,5	20,3	1,2	FCS2WDS177##K45220DE3	
550 2Y	3	4,0	5,6	6,9	150	28,0	22,3	50	32	20	11	27,5	\	0,8	FCS2YDS305##I42700BE3
	5	6,0	8,4	10,4	250	14,0	19,8	50	32	22	13	27,5	\	0,8	FCS2YDS505##I72700BE3
	8	8,5	12,0	12,0	400	12,5	11,1	50	32	28	14	27,5	\	0,8	FCS2YDS805##IC2700BE3
	10	10,0	12,0	12,0	500	8,0	12,5	50	32	33	18	27,5	\	0,8	FCS2YDS106##IF2700BE3
	15	12,0	12,0	12,0	750	6,5	10,7	50	32	37	22	27,5	\	0,8	FCS2YDS156##II2700BE3
	15	13,0	18,3	22,4	750	5,5	10,8	50	32	37	22	27,5	10,2	0,8	FCS2YDS156##II2710BE3
	20	12,5	17,7	21,7	600	6,5	9,8	30	42,5	40	20	37,5	10,2	1	FCS2YDS206##F23710CE3
	22	13,5	19,1	23,4	660	6,5	8,4	30	42,5	40	20	37,5	10,2	1	FCS2YDS226##F23710CE3
	25	14,5	20,5	25,1	750	6,5	7,3	30	42,5	40	20	37,5	10,2	1	FCS2YDS256##F23710CE3
	30	16,0	22,6	27,7	900	6,0	6,5	30	42,5	44	24	37,5	10,2	1	FCS2YDS306##F93710CE3
	35	18,0	25,5	31,3	1050	6,0	5,1	30	42,5	45	30	37,5	20,3	1,2	FCS2YDS356##FF3720DE3
	40	18,0	25,4	31,2	1200	5,5	5,6	30	42,5	45	30	37,5	20,3	1,2	FCS2YDS406##FF3720DE3
	50	20,0	28,2	34,6	1500	5,0	5	30	42,5	50	35	37,5	20,3	1,2	FCS2YDS506##FK3720DE3
	60	18,0	25,5	31,2	900	4,8	6,4	15	57,5	45	30	37,5	20,3	1,2	FCS2YDS606##HH3720DE3
	75	20,0	28,2	34,6	1125	5,0	5	15	57,5	50	35	52,5	20,3	1,2	FCS2YDS756##HL5220DE3
	100	24,0	33,7	36,0	1500	4,5	3,9	15	57,5	55	45	52,5	20,3	1,2	FCS2YDS107##HS5220DE3
	110	26,0	36,0	36,0	1650	4,0	3,7	15	57,5	55	50	52,5	20,3	1,2	FCS2YDS117##HA5220DE3
	130	23,0	32,4	36,0	1950	3,4	5,6	15	57,5	60	35	52,5	20,3	1,2	FCS2YDS137##H65220DE3
	140	25,0	35,5	36,0	2100	3,3	4,8	15	57,5	65	35	52,5	20,3	1,2	FCS2YDS147##KA5220DE3
150	27,0	36,0	36,0	2250	3,1	4,4	15	57,5	70	35	52,5	20,3	1,2	FCS2YDS157##H85220DE3	
160	29,0	36,0	36,0	2400	3,0	4	15	57,5	80	35	52,5	20,3	1,2	FCS2YDS167##K45220DE3	
170	32,0	36,0	36,0	2550	2,8	3,5	15	57,5	80	35	52,5	20,3	1,2	FCS2YDS177##K45220DE3	
600 2S	3	4,0	5,6	6,9	150	28,0	22,3	50	32	20	11	27,5	\	0,8	FCS2SDS305##I42700BE3
	4	5,0	7,0	8,6	200	26,0	15,4	50	32	20	11	27,5	\	0,8	FCS2SDS405##I42700BE3
	5	6,0	8,4	10,3	250	14,5	19,2	50	32	28	14	27,5	\	0,8	FCS2SDS505##IC2700BE3
	8	7,5	10,6	12,0	400	12,0	14,8	50	32	28	14	27,5	\	0,8	FCS2SDS805##IC2700BE3
	10	8,5	12,0	12,0	500	7,5	18,5	50	32	33	18	27,5	\	0,8	FCS2SDS106##IF2700BE3
	12	9,5	12,0	12,0	600	7,5	14,8	50	32	33	18	27,5	\	0,8	FCS2SDS126##IF2700BE3
	12	8,0	11,3	13,8	360	9,5	16,4	30	42,5	18	24	37,5	\	1	FCS2SDS126##FL3700CE3
	15	10,5	12,0	12,0	750	7,5	12,1	50	32	37	22	27,5	\	0,8	FCS2SDS156##II2700BE3
	15	12,0	15,0	15,0	750	6,0	11,6	50	42,5	18	24	37,5	\	1	FCS2SDS156##FL3700CE3
	20	11,0	15,5	19,0	600	6,0	13,8	30	42,5	40	20	37,5	10,2	1	FCS2SDS206##F23710CE3
	30	13,0	18,3	22,4	900	5,5	10,8	30	42,5	37	28	37,5	10,2	1	FCS2SDS306##F13710CE3
	35	16,5	23,4	28,6	1050	5,0	7,3	30	42,5	44	24	37,5	10,2	1	FCS2SDS356##F93710CE3

(1) Maximum permissible peak current, (2) Thermal resistance from hotspot to ambient (free convection)





U <sub>r</sub> ≤85°C (V <sub>DC</sub> )	C <sub>r</sub> (μF)	I <sub>max</sub>			f <sup>(1)</sup> (A)	ESR <sub>typ</sub> 20°C 10kHz (mΩ)	R <sub>th</sub> <sup>(2)</sup> (K/W)	dV/dt 20°C (V/μS)	W +1/-1,5 (mm)	H +1/-1,5 (mm)	T +1/-1,5 (mm)	P <sub>1</sub> ±0,5 (mm)	P <sub>2</sub> ±0,5 (mm)	Ød ±0,05 (mm)	ORDER CODE *# to be defined, see ordering code table	
		70°C 10kHz (A)	60°C 10kHz (A)	≤50°C 10kHz (A)												
<b>600 2S</b>	40	18,0	25,4	31,2	1200	4,0	7,7	30	42,5	45	30	37,5	20,3	1,2	FCS2SDS406##FF3720DE3	
	50	14,0	19,8	24,3	750	6,5	7,8	15	57,5	50	35	52,5	20,3	1,2	FCS2SDS506##HL5220DE3	
	60	16,0	22,6	27,7	900	5,0	7,8	15	57,5	50	35	52,5	20,3	1,2	FCS2SDS606##HL5220DE3	
	70	18,0	25,4	31,1	1050	5,0	6,2	15	57,5	50	35	52,5	20,3	1,2	FCS2SDS706##HL5220DE3	
	80	20,0	28,1	34,5	1200	4,0	6,3	15	57,5	55	45	52,5	20,3	1,2	FCS2SDS806##HS5220DE3	
	90	24,0	34,0	36,0	1350	4,0	4,3	15	57,5	55	45	52,5	20,3	1,2	FCS2SDS906##HS5220DE3	
	100	26,0	36,0	36,0	1500	4,0	3,7	15	57,5	53	50	52,5	20,3	1,2	FCS2SDS107##HA5220DE3	
	110	28,0	36,0	36,0	1650	3,5	3,6	15	57,5	53	50	52,5	20,3	1,2	FCS2SDS117##HA5220DE3	
	120	30,0	36,0	36,0	1800	3,4	3,3	15	57,5	60	35	52,5	20,3	1,2	FCS2SDS127##H65220DE3	
	130	32,0	36,0	36,0	1950	3,3	3	15	57,5	65	35	52,5	20,3	1,2	FCS2SDS137##KA5220DE3	
	140	34,0	36,0	36,0	2100	3,2	2,7	15	57,5	70	35	52,5	20,3	1,2	FCS2SDS147##H85220DE3	
	140	34,0	36,0	36,0	2100	3,2	2,7	15	57,5	65	45	52,5	20,3	1,2	FCS2SDS147##H75220DE3	
	150	36,0	36,0	36,0	2250	3,0	2,6	15	57,5	80	35	52,5	20,3	1,2	FCS2SDS157##K45220DE3	
	<b>700 2Q</b>	1	2,5	3,5	4,3	75	54,0	29,6	75	32	18	9	27,5	\	0,8	FCS2QDS105##I12700BE3
		2	3,0	4,2	5,1	150	35,0	31,7	75	32	18	9	27,5	\	0,8	FCS2QDS205##I12700BE3
3		4,5	6,3	7,8	150	28,0	17,6	50	32	20	11	27,5	\	0,8	FCS2QDS305##I42700BE3	
3,3		5,5	7,7	9,5	165	26,0	12,7	50	32	28	14	27,5	\	0,8	FCS2QDS335##IC2700BE3	
5		6,0	8,4	10,4	250	14,0	19,8	50	32	28	14	27,5	\	0,8	FCS2QDS505##IC2700BE3	
6		6,0	8,4	10,4	450	14,0	19,8	75	32	28	18	27,5	\	0,8	FCS2QDS605##ID2700BE3	
8		9,0	12,0	12,0	400	10,0	12,3	50	32	33	18	27,5	\	0,8	FCS2QDS805##IF2700BE3	
10		10,0	12,0	12,0	500	7,0	14,3	50	32	33	18	27,5	\	0,8	FCS2QDS106##IF2700BE3	
10		12,0	12,0	12,0	500	6,5	10,7	50	32	37	22	27,5	\	0,8	FCS2QDS106##I12700BE3	
10		11,5	15,0	15,0	300	7,5	10,1	30	42,5	18	24	37,5	\	1	FCS2QDS106##FL3700CE3	
12		12,0	12,0	12,0	600	6,0	10,7	50	32	37	22	27,5	\	0,8	FCS2QDS126##I12700BE3	
12		12,0	15,0	15,0	360	7,0	9,9	30	42,5	18	24	37,5	\	1	FCS2QDS126##FL3700CE3	
15		9,0	12,7	15,0	450	9,0	13,7	30	42,5	33,5	22	37,5	\	1	FCS2QDS156##FT3700CE3	
15		10,0	14,1	17,3	450	8,0	12,5	30	42,5	33,5	22	37,5	10,2	1	FCS2QDS156##FT3710CE3	
15		10,0	14,1	17,3	450	8,0	12,5	30	42,5	40	20	37,5	10,2	1	FCS2QDS156##F23710CE3	
20		12,0	16,9	20,7	600	7,5	9,3	30	42,5	37	28	37,5	10,2	1	FCS2QDS206##F13710CE3	
22		14,0	19,8	24,3	660	6,5	7,8	30	42,5	44	24	37,5	10,2	1	FCS2QDS226##F93710CE3	
25		16,0	22,6	27,7	750	6,0	6,5	30	42,5	44	24	37,5	10,2	1	FCS2QDS256##F93710CE3	
30		16,0	22,6	27,7	900	5,8	6,7	30	42,5	45	30	37,5	20,3	1,2	FCS2QDS306##FF3720DE3	
35		20,0	28,4	34,8	1050	5,5	4,5	30	42,5	50	35	37,5	20,3	1,2	FCS2QDS356##FK3720DE3	
40		14,0	19,8	24,2	600	5,0	10,2	15	57,5	45	30	52,5	20,3	1,2	FCS2QDS406##HH5220DE3	
45		15,5	21,9	26,8	675	5,0	8,3	15	57,5	45	30	52,5	20,3	1,2	FCS2QDS456##HH5220DE3	
50		15,0	21,1	25,9	750	4,8	9,3	15	57,5	50	35	52,5	20,3	1,2	FCS2QDS506##HL5220DE3	
55		16,0	22,6	27,6	825	4,5	8,7	15	57,5	50	35	52,5	20,3	1,2	FCS2QDS556##HL5220DE3	
60		18,0	25,4	31,2	900	4,0	7,7	15	57,5	50	35	52,5	20,3	1,2	FCS2QDS606##HL5220DE3	
65		20,0	28,1	34,5	975	4,0	6,3	15	57,5	55	45	52,5	20,3	1,2	FCS2QDS656##HS5220DE3	
70		20,0	28,2	34,5	1050	3,8	6,6	15	57,5	55	45	52,5	20,3	1,2	FCS2QDS706##HS5220DE3	
75		20,0	28,2	34,5	1125	3,8	6,6	15	57,5	55	45	52,5	20,3	1,2	FCS2QDS756##HS5220DE3	
80		22,0	31,1	36,0	1200	3,5	5,9	15	57,5	53	50	52,5	20,3	1,2	FCS2QDS806##HA5220DE3	
80		23,0	32,4	36,0	1200	3,4	5,6	15	57,5	60	35	52,5	20,3	1,2	FCS2QDS806##H65220DE3	
90		24,0	33,8	36,0	1350	3,5	5	15	57,5	53	50	52,5	20,3	1,2	FCS2QDS906##HA5220DE3	
90		24,0	33,8	36,0	1350	3,5	5	15	57,5	60	35	52,5	20,3	1,2	FCS2QDS906##H65220DE3	
100		26,0	36,0	36,0	1500	3,5	4,2	15	57,5	53	50	52,5	20,3	1,2	FCS2QDS107##HA5220DE3	
100		26,0	36,0	36,0	1500	3,5	4,2	15	57,5	65	35	52,5	20,3	1,2	FCS2QDS107##KA5220DE3	
110		28,0	36,0	36,0	1650	3,4	3,8	15	57,5	70	35	52,5	20,3	1,2	FCS2QDS117##H85220DE3	
120	30,0	36,0	36,0	1800	3,0	3,7	15	57,5	80	35	52,5	20,3	1,2	FCS2QDS127##K45220DE3		
130	32,0	36,0	36,0	1950	2,8	3,5	15	57,5	65	45	52,5	20,3	1,2	FCS2QDS137##H75220DE3		
<b>800 2K</b>	1	2,0	2,8	3,4	75	62,0	40,3	75	32	18	9	27,5	\	0,8	FCS2KDS105##I12700BE3	
	2	3,5	4,9	6,0	150	31,0	26,3	75	32	20	11	27,5	\	0,8	FCS2KDS205##I42700BE3	
	3	4,5	6,3	7,7	225	21,0	23,5	75	32	22	13	27,5	\	0,8	FCS2KDS305##I72700BE3	
	3,3	4,0	5,6	6,9	165	25,0	25	50	32	28	14	27,5	\	0,8	FCS2KDS335##IC2700BE3	
	5	6,0	8,4	10,4	250	12,0	23,1	50	32	28	14	27,5	\	0,8	FCS2KDS505##IC2700BE3	
	6	7,5	10,6	12,0	450	10,5	16,9	75	32	28	18	27,5	\	0,8	FCS2KDS605##ID2700BE3	
	8	9,5	12,0	12,0	176	9,5	11,7	22	32	33	18	27,5	\	0,8	FCS2KDS805##IF2700BE3	
	9	10,0	12,0	12,0	198	8,5	11,8	22	32	33	18	27,5	\	0,8	FCS2KDS905##IF2700BE3	
	10	11,5	12,0	12,0	220	9,5	8	22	32	37	22	27,5	\	0,8	FCS2KDS106##I12700BE3	
	10	8,0	11,3	13,8	300	12,5	12,5	30	42,5	32	19	37,5	\	1	FCS2KDS106##F53700CE3	
	15	10,0	14,1	17,3	450	8,0	12,5	30	42,5	40	20	37,5	10,2	1	FCS2KDS156##F23710CE3	
	20	12,0	16,9	20,8	600	7,0	9,9	30	42,5	37	28	37,5	10,2	1	FCS2KDS206##F13710CE3	
	20	13,5	19,1	23,4	600	6,5	8,4	30	42,5	44	24	37,5	10,2	1	FCS2KDS206##F93710CE3	
	22	14,0	19,8	24,2	660	6,0	8,5	30	42,5	44	24	37,5	10,2	1	FCS2KDS226##F93710CE3	
	25	14,0	19,7	24,2	425	5,5	9,3	17	42,5	45	30	37,5	20,3	1,2	FCS2KDS256##FF3720DE3	
	30	16,0	22,6	27,6	900	4,5	8,7	30	42,5	45	30	37,5	20,3	1,2	FCS2KDS306##FF3720DE3	
	35	14,2	20,1	24,6	420	6,5	7,6	12	57,5	45	30	52,5	20,3	1,2	FCS2KDS356##HH5220DE3	

(1) Maximum permissible peak current, (2) Thermal resistance from hotspot to ambient (free convection)





U <sub>r</sub> ≤85°C (V <sub>DC</sub> )	C <sub>r</sub> (μF)	I <sub>max</sub>			f̂ (1)	ESR <sub>typ</sub> 20°C 10kHz (mΩ)	R <sub>th</sub> (2) (K/W)	dV/dt 20°C (V/μS)	W +1/-1,5 (mm)	H +1/-1,5 (mm)	T +1/-1,5 (mm)	P <sub>1</sub> ±0,5 (mm)	P <sub>2</sub> ±0,5 (mm)	Ød ±0,05 (mm)	ORDER CODE *# to be defined, see ordering code table
		70°C 10kHz (A)	60°C 10kHz (A)	≤50°C 10kHz (A)											
<b>800 2K</b>	40	14,0	19,8	24,2	600	6,0	8,5	15	57,5	45	30	52,5	20,3	1,2	FCS2KDS406##HH5220DE3
	45	15,5	21,8	26,7	675	5,5	7,6	15	57,5	45	30	52,5	20,3	1,2	FCS2KDS456##HH5220DE3
	47	17,5	24,8	30,3	564	5,0	6,5	12	57,5	50	35	52,5	20,3	1,2	FCS2KDS476##HL5220DE3
	50	16,0	22,6	27,7	600	5,0	7,8	12	57,5	50	35	52,5	20,3	1,2	FCS2KDS506##HL5220DE3
	55	17,0	24,0	29,4	660	4,6	7,5	12	57,5	50	35	52,5	20,3	1,2	FCS2KDS556##HL5220DE3
	65	19,0	26,9	32,9	780	4,0	6,9	12	57,5	60	35	52,5	20,3	1,2	FCS2KDS656##H65220DE3
	65	20,0	28,1	34,5	975	4,0	6,3	15	57,5	55	45	52,5	20,3	1,2	FCS2KDS656##HS5220DE3
	70	20,0	28,2	34,5	1050	3,8	6,6	15	57,5	55	45	52,5	20,3	1,2	FCS2KDS706##HS5220DE3
	70	20,0	28,2	34,5	1050	3,8	6,6	15	57,5	60	35	52,5	20,3	1,2	FCS2KDS706##H65220DE3
	75	22,0	31,2	36,0	1125	3,8	5,4	15	57,5	55	45	52,5	20,3	1,2	FCS2KDS756##HS5220DE3
	75	22,0	31,2	36,0	1125	3,8	5,4	15	57,5	65	35	52,5	20,3	1,2	FCS2KDS756##KA5220DE3
	80	23,0	32,5	36,0	1200	3,5	5,4	15	57,5	53	50	52,5	20,3	1,2	FCS2KDS806##HA5220DE3
	80	23,0	32,5	36,0	1200	3,5	5,4	15	57,5	70	35	52,5	20,3	1,2	FCS2KDS806##H85220DE3
	90	25,0	35,5	36,0	1350	3,3	4,8	15	57,5	53	50	52,5	20,3	1,2	FCS2KDS906##HA5220DE3
90	25,0	35,5	36,0	1350	3,3	4,8	15	57,5	80	35	52,5	20,3	1,2	FCS2KDS906##K45220DE3	
100	28,0	36,0	36,0	1500	3,2	4	15	57,5	65	45	52,5	20,3	1,2	FCS2KDS107##H75220DE3	
<b>900 R2</b>	1	2,0	2,8	3,4	60	63,0	39,7	60	32	18	9	27,5	\	0,8	FCSR2DS105##I12700BE3
	2	3,0	4,2	5,1	120	25,0	44,4	60	32	20	11	27,5	\	0,8	FCSR2DS205##I42700BE3
	3	5,0	7,0	8,6	180	18,5	21,6	60	32	22	13	27,5	\	0,8	FCSR2DS305##I72700BE3
	3,3	5,0	7,0	8,6	198	18,5	21,6	60	32	24,5	15	27,5	\	0,8	FCSR2DS335##I12700BE3
	5	7,0	9,9	12,0	300	12,5	16,3	60	32	28	18	27,5	\	0,8	FCSR2DS505##ID2700BE3
	6	8,0	11,3	12,0	360	11,0	14,2	60	32	33	18	27,5	\	0,8	FCSR2DS605##IF2700BE3
	8	10,5	12,0	12,0	480	10,0	9,1	60	32	37	22	27,5	\	0,8	FCSR2DS805##I12700BE3
	10	12,0	12,0	12,0	600	10,0	6,9	60	32	37	22	27,5	\	0,8	FCSR2DS106##I12700BE3
	10	8,5	12,0	14,7	350	12,0	11,5	35	42,5	40	20	37,5	\	1	FCSR2DS106##F23700CE3
	10	9,5	13,4	16,4	350	11,5	9,6	35	42,5	40	20	37,5	10,2	1	FCSR2DS106##F23710CE3
	15	10,5	14,8	15,0	525	8,0	11,3	35	42,5	44	24	37,5	\	1	FCSR2DS156##F93700CE3
	18	10,5	14,8	15,0	630	8,0	11,3	35	42,5	44	24	37,5	\	1	FCSR2DS186##F93700CE3
	18	12,0	16,9	20,7	630	7,5	9,3	35	42,5	44	24	37,5	10,2	1	FCSR2DS186##F93710CE3
	20	14,0	15,0	15,0	700	6,0	8,5	35	42,5	45	30	37,5	\	1	FCSR2DS206##FF3700CE3
	20	15,0	21,1	25,9	700	5,5	8,1	35	42,5	45	30	37,5	20,3	1,2	FCSR2DS206##FF3720DE3
	25	17,0	24,0	29,4	875	5,5	6,3	35	42,5	45	30	37,5	20,3	1,2	FCSR2DS256##FF3720DE3
	30	19,0	26,9	33,0	1050	5,0	5,5	35	42,5	50	35	37,5	20,3	1,2	FCSR2DS306##FK3720DE3
	30	15,0	21,1	25,9	450	5,5	8,1	15	57,5	45	30	52,5	20,3	1,2	FCSR2DS306##HH5220DE3
	35	15,5	21,8	26,7	525	5,5	7,6	15	57,5	50	35	52,5	20,3	1,2	FCSR2DS356##HL5220DE3
	40	16,0	22,6	27,7	600	6,5	6	15	57,5	50	35	52,5	20,3	1,2	FCSR2DS406##HL5220DE3
	50	18,0	25,4	31,1	750	3,6	8,6	15	57,5	50	35	52,5	20,3	1,2	FCSR2DS506##HL5220DE3
	55	19,0	26,8	32,9	825	3,5	7,9	15	57,5	60	35	52,5	20,3	1,2	FCSR2DS556##H65220DE3
	55	20,0	28,1	34,5	825	3,4	7,4	15	57,5	55	45	52,5	20,3	1,2	FCSR2DS556##HS5220DE3
	60	20,0	28,1	34,5	900	3,4	7,4	15	57,5	55	45	52,5	20,3	1,2	FCSR2DS606##HS5220DE3
	60	20,0	28,1	34,5	900	3,4	7,4	15	57,5	65	35	52,5	20,3	1,2	FCSR2DS606##KA5220DE3
	65	22,0	31,0	36,0	975	3,3	6,3	15	57,5	70	35	52,5	20,3	1,2	FCSR2DS656##H85220DE3
	70	24,0	34,0	36,0	1050	3,2	5,4	15	57,5	53	50	52,5	20,3	1,2	FCSR2DS706##HA5220DE3
	70	24,0	34,0	36,0	1050	3,2	5,4	15	57,5	80	35	52,5	20,3	1,2	FCSR2DS706##K45220DE3
80	25,0	35,3	36,0	1200	3,2	5	15	57,5	65	45	52,5	20,3	1,2	FCSR2DS806##H75220DE3	
<b>1000 3A</b>	1	2,5	3,5	4,3	70	45,0	35,6	70	32	20	11	27,5	\	0,8	FCS3ADS105##I42700BE3
	2	3,5	4,9	6,0	120	30,0	27,2	60	32	22	13	27,5	\	0,8	FCS3ADS205##I72700BE3
	3	5,0	7,0	8,6	180	25,0	16	60	32	24,5	15	27,5	\	0,8	FCS3ADS305##I12700BE3
	5	8,0	11,2	12,0	300	14,0	11,2	60	32	33	18	27,5	\	0,8	FCS3ADS505##IF2700BE3
	8	10,0	12,0	12,0	480	12,0	8,3	60	32	37	22	27,5	\	0,8	FCS3ADS805##I12700BE3
	10	8,5	12,0	14,7	350	12,0	11,5	35	42,5	40	20	37,5	\	1	FCS3ADS106##F23700CE3
	10	9,5	13,4	16,4	350	11,5	9,6	35	42,5	40	20	37,5	10,2	1	FCS3ADS106##F23710CE3
	12	10,5	14,8	18,1	420	9,0	10,1	35	42,5	44	24	37,5	10,2	1	FCS3ADS126##F93710CE3
	15	10,5	14,8	15,0	525	8,0	11,3	35	42,5	44	24	37,5	\	1	FCS3ADS156##F93700CE3
	15	12,0	16,9	20,7	525	7,5	9,3	35	42,5	44	24	37,5	10,2	1	FCS3ADS156##F93710CE3
	15	14,0	19,8	24,2	525	7,5	6,8	35	42,5	45	30	37,5	20,3	1,2	FCS3ADS156##FF3720DE3
	20	15,0	21,2	26,0	700	6,5	6,8	35	42,5	45	30	37,5	20,3	1,2	FCS3ADS206##FF3720DE3
	25	18,0	25,4	31,2	875	5,5	5,6	35	42,5	50	35	37,5	20,3	1,2	FCS3ADS256##FK3720DE3
	30	15,0	21,1	25,9	450	5,5	8,1	15	57,5	45	30	52,5	20,3	1,2	FCS3ADS306##HH5220DE3
	35	16,0	22,6	27,7	525	5,5	7,1	15	57,5	50	35	52,5	20,3	1,2	FCS3ADS356##HL5220DE3
	40	16,0	22,6	27,7	600	5,0	7,8	15	57,5	50	35	52,5	20,3	1,2	FCS3ADS406##HL5220DE3
	40	17,0	24,0	29,4	600	5,0	6,9	15	57,5	60	35	52,5	20,3	1,2	FCS3ADS406##H65220DE3
	50	19,0	26,7	32,7	750	4,5	6,2	15	57,5	55	45	52,5	20,3	1,2	FCS3ADS506##HS5220DE3
	50	19,0	26,7	32,7	750	4,5	6,2	15	57,5	65	35	52,5	20,3	1,2	FCS3ADS506##KA5220DE3

(1) Maximum permissible peak current, (2) Thermal resistance from hotspot to ambient (free convection)







U <sub>r</sub> ≤85°C (V <sub>DC</sub> )	C <sub>r</sub> (μF)	I <sub>max</sub>			ḟ <sup>(1)</sup> (A)	ESR <sub>typ</sub> 20°C 10kHz (mΩ)	R <sub>th</sub> <sup>(2)</sup> (K/W)	dV/dt 20°C (V/μS)	W +1/-1,5 (mm)	H +1/-1,5 (mm)	T +1/-1,5 (mm)	P <sub>1</sub> ±0,5 (mm)	P <sub>2</sub> ±0,5 (mm)	Ød ±0,05 (mm)	ORDER CODE *# to be defined, see ordering code table
		70°C 10kHz (A)	60°C 10kHz (A)	≤50°C 10kHz (A)											
<b>1000 3A</b>	55	20,0	28,2	34,5	825	4,4	5,7	15	57,5	70	35	52,5	20,3	1,2	FCS3ADS556##H85220DE3
	60	22,0	31,0	36,0	900	4,0	5,2	15	57,5	53	50	52,5	20,3	1,2	FCS3ADS606##HA5220DE3
	60	22,0	31,0	36,0	900	4,0	5,2	15	57,5	80	35	52,5	20,3	1,2	FCS3ADS606##K45220DE3
	60	22,0	31,0	36,0	900	4,0	5,2	15	57,5	65	45	52,5	20,3	1,2	FCS3ADS606##H75220DE3
<b>1100 A3</b>	1	2,5	3,5	4,3	70	45,0	35,6	70	32	20	11	27,5	\	0,8	FCSA3DS105##142700BE3
	1,5	3,5	4,9	6,0	105	30,0	27,2	70	32	22	13	27,5	\	0,8	FCSA3DS155##172700BE3
	2	4,0	5,6	6,9	140	25,0	25	70	32	24,5	15	27,5	\	0,8	FCSA3DS205##112700BE3
	2,2	5,0	7,0	8,6	154	16,5	24,2	70	32	28	14	27,5	\	0,8	FCSA3DS225##1C2700BE3
	3,3	6,5	9,1	11,2	231	11,5	20,6	70	32	28	18	27,5	\	0,8	FCSA3DS335##1D2700BE3
	4	8,0	11,3	12,0	280	10,5	14,9	70	32	33	18	27,5	\	0,8	FCSA3DS405##1F2700BE3
	5	8,5	12,0	12,0	350	9,5	14,6	70	32	37	22	27,5	\	0,8	FCSA3DS505##1I2700BE3
	6,8	12,0	17,0	20,8	272	13,5	5,1	40	42,5	33,5	22	37,5	10,2	1	FCSA3DS685##FT3710CE3
	8	10,5	14,8	15,0	320	14,0	6,5	40	42,5	40	20	37,5	\	1	FCSA3DS805##F23700CE3
	8	12,5	17,7	21,7	320	12,5	5,1	40	42,5	40	20	37,5	10,2	1	FCSA3DS805##F23710CE3
	8	12,5	17,7	21,7	320	12,5	5,1	40	42,5	37	22	37,5	10,2	1	FCSA3DS805##FQ3710CE3
	9	12,8	18,1	22,1	360	12,2	5	40	42,5	37	22	37,5	10,2	1	FCSA3DS905##FQ3710CE3
	10	14,0	15,0	15,0	400	9,0	5,7	40	42,5	44	24	37,5	\	1	FCSA3DS106##F93700CE3
	10	15,0	21,2	26,0	400	8,5	5,2	40	42,5	44	24	37,5	10,2	1	FCSA3DS106##F93710CE3
	12	15,5	22,0	26,9	480	7,5	5,5	40	42,5	45	30	37,5	20,3	1,2	FCSA3DS126##FF3720DE3
	15	16,0	22,5	27,6	600	7,0	5,6	40	42,5	45	30	37,5	20,3	1,2	FCSA3DS156##FF3720DE3
	18	15,5	22,0	26,9	720	7,5	5,5	40	42,5	50	35	37,5	20,3	1,2	FCSA3DS186##FK3720DE3
	20	16,5	23,3	28,5	400	7,2	5,1	20	42,5	50	35	37,5	20,3	1,2	FCSA3DS206##FK3720DE3
	20	12,0	16,9	20,7	400	8,5	8,2	20	57,5	45	30	52,5	20,3	1,2	FCSA3DS206##HH5220DE3
	25	13,0	18,4	22,5	500	8,2	7,2	20	57,5	50	35	52,5	20,3	1,2	FCSA3DS256##HL5220DE3
	30	15,0	21,1	25,9	600	5,0	8,9	20	57,5	50	35	52,5	20,3	1,2	FCSA3DS306##HL5220DE3
	35	16,0	22,5	27,6	700	4,9	8	20	57,5	60	35	52,5	20,3	1,2	FCSA3DS356##H65220DE3
	40	17,0	24,0	29,4	800	5,5	6,3	20	57,5	65	35	52,5	20,3	1,2	FCSA3DS406##KA5220DE3
	40	17,0	24,0	29,4	800	5,5	6,3	20	57,5	55	45	52,5	20,3	1,2	FCSA3DS406##HS5220DE3
	45	18,0	25,4	31,2	900	5,4	5,7	20	57,5	70	35	52,5	20,3	1,2	FCSA3DS456##H85220DE3
50	19,5	27,4	33,6	1000	5,2	5,1	20	57,5	65	45	52,5	20,3	1,2	FCSA3DS506##H75220DE3	
50	20,0	28,1	34,5	1000	4,5	5,6	20	57,5	53	50	52,5	20,3	1,2	FCSA3DS506##HA5220DE3	
<b>1200 3B</b>	1	4,5	6,3	7,7	80	32,5	15,2	80	32	20	11	27,5	\	0,8	FCS3BDS105##142700BE3
	2	5,0	7,0	8,6	160	32,5	12,3	80	32	24,5	15	27,5	\	0,8	FCS3BDS205##112700BE3
	2,2	5,5	7,7	9,5	176	17,0	19,4	80	32	28	18	27,5	\	0,8	FCS3BDS225##1D2700BE3
	3	7,0	9,8	12,0	240	16,0	12,8	80	32	28	18	27,5	\	0,8	FCS3BDS305##1D2700BE3
	3,3	8,0	11,3	12,0	264	13,5	11,6	80	32	33	18	27,5	\	0,8	FCS3BDS335##1F2700BE3
	5	10,0	12,0	12,0	400	12,0	8,3	80	32	37	22	27,5	\	0,8	FCS3BDS505##1I2700BE3
	5	7,5	10,5	12,9	225	15,5	11,5	45	42,5	33,5	22	37,5	\	1	FCS3BDS505##FT3700CE3
	6	7,5	10,5	12,9	270	15,5	11,5	45	42,5	40	20	37,5	\	1	FCS3BDS605##F23700CE3
	7	8,0	11,3	13,8	315	15,2	10,3	45	42,5	37	22	37,5	10,2	1	FCS3BDS705##FQ3710CE3
	8	9,0	12,7	15,5	360	12,5	9,9	45	42,5	44	24	37,5	10,2	1	FCS3BDS805##F93710CE3
	10	10,0	14,1	17,3	450	10,5	9,5	45	42,5	44	24	37,5	10,2	1	FCS3BDS106##F93710CE3
	10	12,0	16,9	20,7	450	8,0	8,7	45	42,5	45	30	37,5	20,3	1,2	FCS3BDS106##FF3720DE3
	15	15,0	21,2	26,0	675	6,5	6,8	45	42,5	50	35	37,5	20,3	1,2	FCS3BDS156##FK3720DE3
	20	13,0	18,3	22,4	500	8,5	7	25	57,5	45	30	52,5	20,3	1,2	FCS3BDS206##HH5220DE3
	25	15,0	21,2	26,0	625	6,5	6,8	25	57,5	50	35	52,5	20,3	1,2	FCS3BDS256##HL5220DE3
	30	17,0	24,0	29,4	750	5,5	6,3	25	57,5	55	45	52,5	20,3	1,2	FCS3BDS306##HS5220DE3
	30	17,0	24,0	29,4	750	5,5	6,3	25	57,5	60	35	52,5	20,3	1,2	FCS3BDS306##H65220DE3
35	18,0	25,4	31,1	875	5,0	6,2	25	57,5	55	45	52,5	20,3	1,2	FCS3BDS356##HS5220DE3	
35	18,0	25,4	31,1	875	5,0	6,2	25	57,5	70	35	52,5	20,3	1,2	FCS3BDS356##H85220DE3	
40	20,0	28,1	34,5	1000	4,5	5,6	25	57,5	53	50	52,5	20,3	1,2	FCS3BDS406##HA5220DE3	
45	22,0	31,1	36,0	1125	4,3	4,8	25	57,5	65	45	52,5	20,3	1,2	FCS3BDS456##H75220DE3	
<b>1500 C3</b>	6,5	12,0	17,0	20,8	293	10,5	6,6	45	42	42	28	37,5	10,3	1,0	FCSC3DS655##FH3710CE3
	11	20,0	28,4	34,8	71	6,5	3,8	30	42	50	35	37,5	20,3	1,2	FCSC3DS116##FK3720DE3

(1) Maximum permissible peak current, (2) Thermal resistance from hotspot to ambient (free convection)

DC-LINK

**FEATURES**

- 105°C
- Very low dissipation factor
- Highest peak pulse capability
- Double-sided metallized electrodes
- Internal series connection
- Metal sprayed contacts for low ESL
- Plates for direct IGBT connection
- Self-healing

**OVERVIEW**

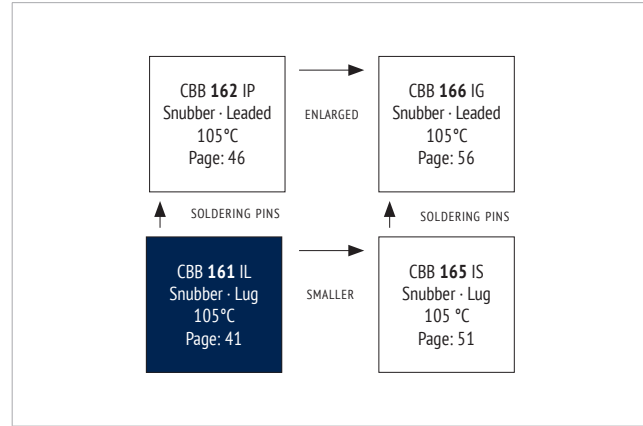

**PRODUCT**



**APPLICATIONS**

- High pulse and high frequency circuits
- IGBT applications

**CHARACTERISTICS**

ITEM	CHARACTERISTICS
Climatic Category	40/105/56 (IEC 61071)
Operating Temperature	-40 ~ +105 °C ( $\Theta_{hotspot} \leq 105$ °C) $\Theta_{hotspot} = 85-105$ °C: See Voltage Derating Diagram
Storage Temperature	-40 ~ +105 °C
Rated Voltage $U_{RDC}$	700 ~ 2.000 $V_{DC}$
Capacitance Range	0,2 ~ 7,5 $\mu F$
Capacitance Tolerance	$\pm 10$ % (K), $\pm 5$ % (J)
Voltage between Terminals $U_{TT}$	$1,5 \cdot U_{RDC}$ (20°C, 10s)
Voltage between Terminals & Case $U_{TC}$	$3.000 V_{AC}$ (20°C, 50 Hz, 10s)
Capacitor Dissipation Factor $\tan \delta$	$\leq 5 \cdot 10^{-4}$ (20 °C, 1 kHz)
Dielectric Dissipation Factor $\tan \delta_o$	$\leq 2 \cdot 10^{-4}$ (20 °C, 1 kHz)
Insulation Resistance $R_i$ °C	$\geq 10.000 M\Omega \cdot \mu F$ (20 °C, 100 $V_{DC}$ , 1 min)
Max. Overvoltage	Please see IEC 61071
Life Time Expectancy	$\geq 100.000h$ , failure rate $\leq 50$ FIT (70°C)
Reference Standard	IEC 61071:2007, REACH, RoHS

**ENVIRONMENTAL**

The products are RoHS, WEEE and REACH compliant.

The detailed version please see separate "Environmental Certificates" document or [www.jianghai-europe.com](http://www.jianghai-europe.com)

SNUBBER

**APPROVALS**

**UL94-V0:**  
Plastic & Compound Mass

**LIFETIME**

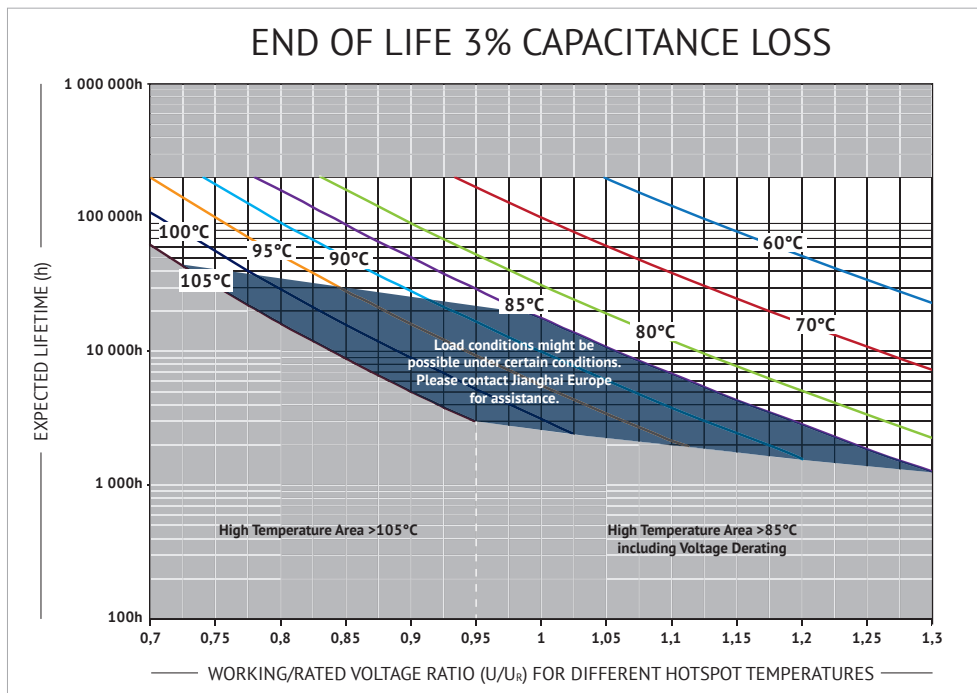

**CURRENT DERATING**

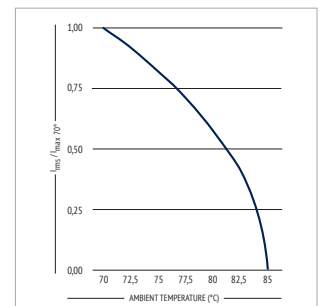

**VOLTAGE DERATING**

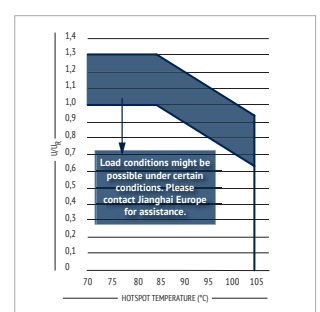

**DIMENSIONS**

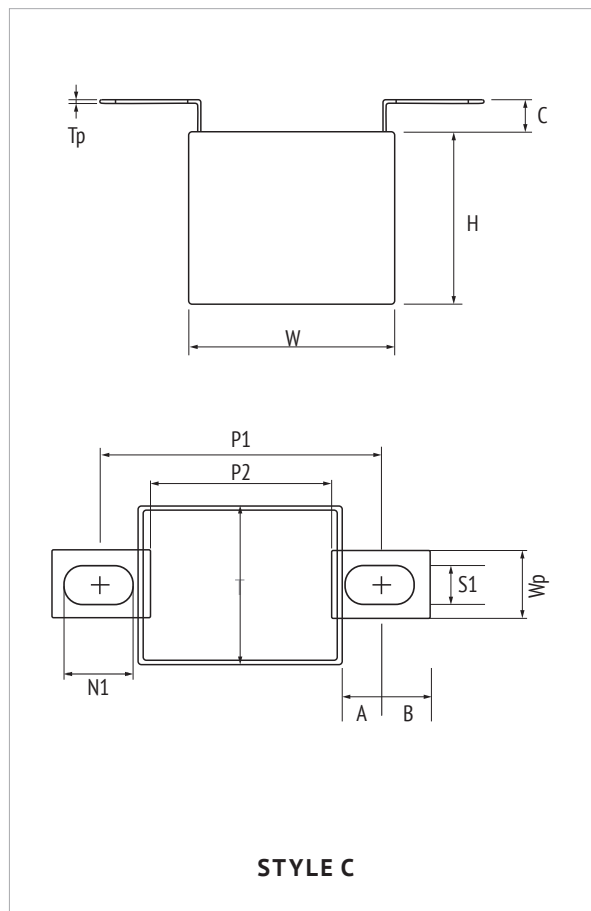
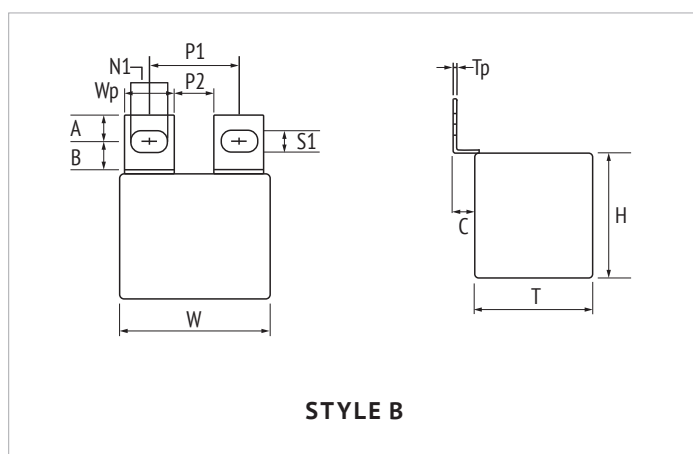
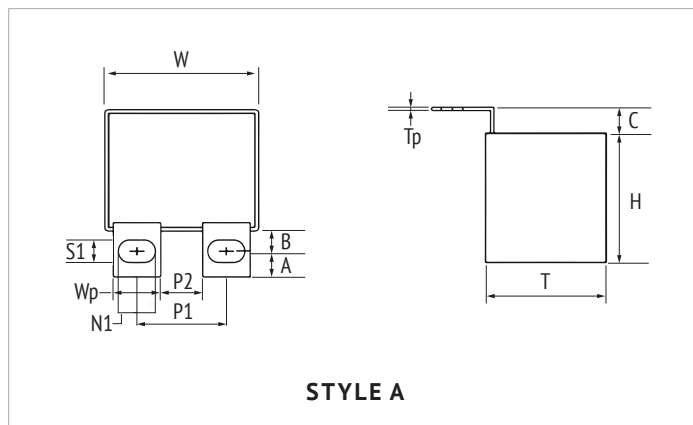

SNUBBER

Terminal Style	Length of Case W+1/-1,5 (mm)	Mounting Hole Pitch P1±0,5 (mm)	Gap between Terminals P2±0,5 (mm)	Width Terminal Plate Wp±0,3 (mm)	Thickness Terminal Tp±0,1 (mm)	Distance of Terminal C±1 (mm)	Width of Hole S1±0,1 (mm)	Length of Hole N1±0,3 (mm)	Position of Hole A±0,2 (mm)	Distance of Hole B±0,2 (mm)
Style A/B	42,5	24,0	10,0	14,0	1,0	6,0	M6: 6,5 M8: 8,5	M6: 8,5 M8: 10,5	7,0	7,0
Style A/B	42,5	26,0	12,0	14,0	1,0	6,0	M6: 6,5 M8: 8,5	M6: 8,5 M8: 10,5	7,0	7,0
Style A/B	57,5	24,0	10,0	14,0	1,0	6,0	M6: 6,5 M8: 8,5	M6: 8,5 M8: 10,5	7,0	7,0
Style A/B	57,5	37,0	23,0	14,0	1,0	6,0	M6: 6,5 M8: 8,5	M6: 8,5 M8: 10,5	7,0	7,0
Style C	42,5	60,0	38,0	14,0	1,0	6,0	M8: 8,2	M8: 14	8,5	10,0
Style C	57,5	75,0	53,0	14,0	1,0	6,0	M8: 8,2	M8: 14	8,5	10,0

## INTERNAL CONSTRUCTION

NO.	ITEM	MATERIAL
1	Dielectric Film	Polypropylene
2	Single-sided Metallized Film	PP + Al
3	Double-sided Metallized Carrier Film	PET + Al
4	Metal Sprayed Contact	Zn + Sn/Zn
5	Terminal	Sn-coated Cu
6	Potting Compound	Epoxy
7	Case	Flame retardant PBT

## MARKING

	BRAND
<b>CBB 161</b>	PRODUCT SERIES
1µF K 1200V	CAPACITANCE, TOLERANCE AND RATETD VOLTAGE
<b>G03F12</b>	DATE CODE

## ORDER CODE

FC	S	3B	IL	105	K	A	FA	40	26	19	1	E 3
Capacitor type	Product shape	DC rated voltage code (V)	Series code	Capacitance Code (µF)	Capacitance tolerance	Plate Style (mm)	Dimension Code (mm)	Pitch P <sub>1</sub> (mm)	Gap P <sub>2</sub> (mm)	Width of plates Wp (mm)	Hole Shape	For internal use
Film Cap. = FC	Square box = S	700 <b>2Q</b> 850 <b>K2</b> 1000 <b>3A</b> 1200 <b>3B</b> 1600 <b>3C</b> 2000 <b>3D</b>	CBB 161 = IL	0,22 <b>224</b> 0,33 <b>334</b> 0,47 <b>474</b> 0,68 <b>684</b> 0,82 <b>824</b> 1,0 <b>105</b> 1,2 <b>125</b> 1,5 <b>155</b> 2,0 <b>205</b> 2,2 <b>225</b> 2,5 <b>255</b> 3,0 <b>305</b> 3,3 <b>335</b> 4,0 <b>405</b> 4,7 <b>475</b> 5,0 <b>505</b> 6,0 <b>605</b> 6,8 <b>685</b> 10,0 <b>106</b>	±5% <b>J</b> ±10% <b>K</b>	Style A <b>A</b> Style B <b>B</b> Style C <b>C</b>	42,5 x 28 x 24 <b>FA</b> 42,5 x 33 x 33 <b>FB</b> 42,5 x 35,5 x 33,5 <b>FC</b> 42,5 x 36 x 24 <b>FD</b> 42,5 x 43 x 42 <b>FE</b> 42,5 x 45 x 30 <b>FF</b> 57,5 x 43,5 x 29,5 <b>HG</b> 57,5 x 45 x 30 <b>HH</b> 57,5 x 45 x 35 <b>HJ</b> 57,5 x 45 x 45 <b>HK</b> 57,5 x 50 x 35 <b>HL</b> 57,5 x 55 x 40 <b>HM</b>	24 <b>24</b> 26 <b>26</b> 37 <b>37</b> 60 <b>60</b> 75 <b>75</b>	10 <b>10</b> 12 <b>12</b> 23 <b>23</b> 38 <b>38</b> 53 <b>53</b>	14 <b>14</b>	Circular M6 Oval M6: 6,5x8,5 Circular M8 Oval M8: 8,5x10,5 Oval M6: 6,5x10,5 Oval 9x12 Circular ø5,5 Circular ø7,0 Circular ø5,0 Oval 8,5x14,5	<b>0</b> <b>1</b> <b>2</b> <b>3</b> <b>7</b> <b>5</b> <b>A</b> <b>C</b> <b>E</b> <b>D</b>



**RATINGS**

$U_R$	$C_R$	dV/dt	$\hat{i}^{(1)}$	ESR <sub>typ</sub>	$L_s$	$I_{max}$	W	H	T	ORDER CODE
≤85°C		20°C		20°C 100kHz	20°C	70°C 100kHz	+1/-1,5	+1/-1,5	+1/-1,5	"*" to be defined, see ordering code table
(V)	(µF)	(V/µS)	(A)	(mΩ)	(nH)	(A)	(mm)	(mm)	(mm)	
<b>700 V<sub>DC</sub></b> <b>420 V<sub>AC</sub></b> <b>2Q</b>	1,20	325	390	10	≤20	12,4	42,5	28	24	FCS2QIL125##FA###14#E3
	1,80	325	585	8	≤20	16,8	42,5	36	24	FCS2QIL185##FD###14#E3
	2,20	325	715	7	≤20	18,8	42,5	33	33	FCS2QIL225##FB###14#E3
	2,50	325	813	6	≤20	20,3	42,5	35,5	33,5	FCS2QIL255##FC###14#E3
	3,00	325	975	5	≤20	22,4	42,5	45	30	FCS2QIL305##FF###14#E3
	4,00	325	1300	4	≤20	25,0	42,5	43	42	FCS2QIL405##FE###14#E3
	4,20	260	1092	3	≤20	26,0	57,5	43,5	29,5	FCS2QIL425##HG###14#E3
	4,50	260	1170	3	≤20	26,0	57,5	45	30	FCS2QIL455##HH###14#E3
	5,00	260	1300	3	≤20	27,0	57,5	45	35	FCS2QIL505##HJ###14#E3
	5,50	260	1430	2	≤20	27,0	57,5	50	35	FCS2QIL555##HL###14#E3
	6,00	260	1560	2	≤20	28,0	57,5	45	45	FCS2QIL605##HK###14#E3
	7,50	260	1950	2	≤20	30,0	57,5	55	40	FCS2QIL755##HM###14#E3
<b>850 V<sub>DC</sub></b> <b>450 V<sub>AC</sub></b> <b>K2</b>	0,47	650	306	10	≤20	11,5	42,5	28	24	FCSK2IL474##FA###14#E3
	0,70	650	455	10	≤20	15,3	42,5	36	24	FCSK2IL704##FD###14#E3
	0,80	650	520	10	≤20	11,8	42,5	28	24	FCSK2IL804##FA###14#E3
	0,80	650	520	9	≤20	17,2	42,5	35,5	33,5	FCSK2IL804##FC###14#E3
	1,00	650	650	8	≤20	18,6	42,5	35,5	33,5	FCSK2IL105##FC###14#E3
	1,20	650	780	9	≤20	15,6	42,5	36	24	FCSK2IL125##FD###14#E3
	1,20	650	780	7	≤20	20,6	42,5	45	30	FCSK2IL125##FF###14#E3
	1,50	650	975	8	≤20	17,6	42,5	35,5	33,5	FCSK2IL155##FC###14#E3
	1,50	650	975	6	≤20	22,0	42,5	43	42	FCSK2IL155##FE###14#E3
	1,50	455	683	6	≤20	22,0	57,5	43,5	29,5	FCSK2IL155##HG###14#E3
	1,80	650	1170	7	≤20	19,8	42,5	35,5	33,5	FCSK2IL185##FC###14#E3
	1,80	455	819	6	≤20	23,0	57,5	45	30	FCSK2IL185##HH###14#E3
	2,00	455	910	5	≤20	24,0	57,5	45	35	FCSK2IL205##HJ###14#E3
	2,20	650	1430	6	≤20	21,5	42,5	45	30	FCSK2IL225##FF###14#E3
	2,20	455	1001	5	≤20	24,0	57,5	50	35	FCSK2IL225##HL###14#E3
	2,50	455	1138	4	≤20	25,0	57,5	45	45	FCSK2IL255##HK###14#E3
	2,80	650	1820	5	≤20	24,0	42,5	43	42	FCSK2IL285##FE###14#E3
	3,00	455	1365	4	≤20	24,0	57,5	43,5	29,5	FCSK2IL305##HG###14#E3
	3,00	455	1365	4	≤20	25,0	57,5	45	30	FCSK2IL305##HH###14#E3
	3,00	455	1365	4	≤20	26,0	57,5	55	40	FCSK2IL305##HM###14#E3
	3,50	455	1592	4	≤20	25,0	57,5	45	35	FCSK2IL355##HJ###14#E3
	4,50	455	2047	3	≤20	27,0	57,5	50	35	FCSK2IL455##HL###14#E3
5,00	455	2275	3	≤20	27,0	57,5	45	45	FCSK2IL505##HK###14#E3	
5,00	455	2275	2	≤20	29,0	57,5	55	40	FCSK2IL505##HM###14#E3	
<b>1000 V<sub>DC</sub></b> <b>500 V<sub>AC</sub></b> <b>3A</b>	0,65	500	325	10	≤20	11,6	42,5	28	24	FCS3AIL654##FA###14#E3
	1,00	500	500	9	≤20	15,5	42,5	36	24	FCS3AIL105##FD###14#E3
	1,20	500	600	8	≤20	17,5	42,5	35,5	33,5	FCS3AIL125##FC###14#E3
	1,40	500	700	7	≤20	18,8	42,5	35,5	33,5	FCS3AIL145##FC###14#E3
	1,80	500	900	6	≤20	21,0	42,5	45	30	FCS3AIL185##FF###14#E3
	2,20	500	1100	5	≤20	23,0	42,5	43	42	FCS3AIL225##FE###14#E3
	2,20	350	770	6	≤20	23,0	57,5	43,5	29,5	FCS3AIL225##HG###14#E3
	2,50	350	875	5	≤20	24,0	57,5	45	30	FCS3AIL255##HH###14#E3
	3,00	350	1050	5	≤20	24,0	57,5	45	35	FCS3AIL305##HJ###14#E3
	3,30	350	1155	4	≤20	25,0	57,5	50	35	FCS3AIL335##HL###14#E3
	3,50	350	1225	4	≤20	25,0	57,5	45	45	FCS3AIL355##HK###14#E3
	4,50	350	1575	4	≤20	28,0	57,5	55	40	FCS3AIL455##HM###14#E3
<b>1200 V<sub>DC</sub></b> <b>600 V<sub>AC</sub></b> <b>3B</b>	0,33	800	264	11	≤20	11,4	42,5	28	24	FCS3BIL334##FA###14#E3
	0,47	800	376	10	≤20	11,5	42,5	28	24	FCS3BIL474##FA###14#E3
	0,50	800	400	10	≤20	15,0	42,5	36	24	FCS3BIL504##FD###14#E3
	0,60	800	480	9	≤20	16,8	42,5	35,5	33,5	FCS3BIL604##FC###14#E3
	0,70	800	560	9	≤20	18,4	42,5	35,5	33,5	FCS3BIL704##FC###14#E3
	0,70	800	560	10	≤20	15,3	42,5	36	24	FCS3BIL704##FD###14#E3
	0,80	800	640	9	≤20	17,2	42,5	35,5	33,5	FCS3BIL804##FC###14#E3
	0,80	800	640	8	≤20	20,5	42,5	45	30	FCS3BIL804##FF###14#E3
	1,00	800	800	8	≤20	18,6	42,5	35,5	33,5	FCS3BIL105##FC###14#E3
	1,00	800	800	7	≤20	21,0	42,5	43	42	FCS3BIL105##FE###14#E3
	1,00	560	560	6	≤20	22,0	57,5	43,5	29,5	FCS3BIL105##HG###14#E3
	1,20	800	960	7	≤20	20,6	42,5	45	30	FCS3BIL125##FF###14#E3
	1,20	560	672	6	≤20	22,0	57,5	45	30	FCS3BIL125##HH###14#E3

(1) Maximum permissible peak current

>>

SNUBBER





$U_R$	$C_R$	dV/dt	$\hat{I}^{(1)}$	ESR <sub>typ</sub>	$L_S$	$I_{max}$	W	H	T	ORDER CODE
≤85°C		20°C		20°C 100kHz	20°C	70°C 100kHz	+1/-1,5	+1/-1,5	+1/-1,5	"#" to be defined, see ordering code table
(V)	(μF)	(V/μS)	(A)	(mΩ)	(nH)	(A)	(mm)	(mm)	(mm)	
<b>1200 V<sub>DC</sub></b> <b>600 V<sub>AC</sub></b> <b>3B</b>	1,40	560	784	5	≤20	23,0	57,5	45	35	FCS3BIL145##HJ###14#E3
	1,50	800	1200	6	≤20	22,0	42,5	43	42	FCS3BIL155##FE###14#E3
	1,50	560	840	6	≤20	22,0	57,5	43,5	29,5	FCS3BIL155##HG###14#E3
	1,60	560	896	5	≤20	23,0	57,5	50	35	FCS3BIL165##HL###14#E3
	1,70	560	952	4	≤20	24,0	57,5	45	45	FCS3BIL175##HK###14#E3
	1,80	560	1008	6	≤20	23,0	57,5	45	30	FCS3BIL185##HH###14#E3
	2,00	560	1120	5	≤20	24,0	57,5	45	35	FCS3BIL205##HJ###14#E3
	2,00	560	1120	4	≤20	25,0	57,5	55	40	FCS3BIL205##HM###14#E3
	2,20	560	1232	5	≤20	24,0	57,5	50	35	FCS3BIL225##HL###14#E3
	2,50	560	1400	4	≤20	25,0	57,5	45	45	FCS3BIL255##HK###14#E3
3,00	560	1680	4	≤20	26,0	57,5	55	40	FCS3BIL305##HM###14#E3	
<b>1600 V<sub>DC</sub></b> <b>650 V<sub>AC</sub></b> <b>3C</b>	0,33	800	264	11	≤20	11,4	42,5	28	24	FCS3CIL334##FA###14#E3
	0,50	800	400	10	≤20	15,0	42,5	36	24	FCS3CIL504##FD###14#E3
	0,60	800	480	9	≤20	16,8	42,5	35,5	33,5	FCS3CIL604##FC###14#E3
	0,70	800	560	9	≤20	18,4	42,5	35,5	33,5	FCS3CIL704##FC###14#E3
	0,80	800	640	8	≤20	20,5	42,5	45	30	FCS3CIL804##FF###14#E3
	1,00	800	800	7	≤20	21,0	42,5	43	42	FCS3CIL105##FE###14#E3
	1,00	560	560	6	≤20	22,0	57,5	43,5	29,5	FCS3CIL105##HG###14#E3
	1,20	560	672	6	≤20	22,0	57,5	45	30	FCS3CIL125##HH###14#E3
	1,40	560	784	5	≤20	23,0	57,5	45	35	FCS3CIL145##HJ###14#E3
	1,60	560	896	5	≤20	23,0	57,5	50	35	FCS3CIL165##HL###14#E3
	1,70	560	952	4	≤20	24,0	57,5	45	45	FCS3CIL175##HK###14#E3
	2,00	560	1120	4	≤20	25,0	57,5	55	40	FCS3CIL205##HM###14#E3
<b>2000 V<sub>DC</sub></b> <b>700 V<sub>AC</sub></b> <b>3D</b>	0,20	1000	200	11	≤20	11,3	42,5	28	24	FCS3DIL204##FA###14#E3
	0,30	1000	300	11	≤20	14,9	42,5	36	24	FCS3DIL304##FD###14#E3
	0,39	1000	390	10	≤20	16,6	42,5	35,5	33,5	FCS3DIL394##FC###14#E3
	0,42	1000	420	9	≤20	18,2	42,5	35,5	33,5	FCS3DIL424##FC###14#E3
	0,56	1000	560	9	≤20	20,1	42,5	45	30	FCS3DIL564##FF###14#E3
	0,70	1000	700	8	≤20	20,0	42,5	43	42	FCS3DIL704##FE###14#E3
	0,75	720	540	8	≤20	21,0	57,5	43,5	29,5	FCS3DIL754##HG###14#E3
	0,82	720	590	7	≤20	21,0	57,5	45	30	FCS3DIL824##HH###14#E3
	0,90	720	648	6	≤20	22,0	57,5	45	35	FCS3DIL904##HJ###14#E3
	1,00	720	720	6	≤20	22,0	57,5	50	35	FCS3DIL105##HL###14#E3
	1,20	720	864	5	≤20	22,0	57,5	45	45	FCS3DIL125##HK###14#E3
	1,40	720	1008	4	≤20	24,0	57,5	55	40	FCS3DIL145##HM###14#E3

(1) Maximum permissible peak current

SNUBBER

## FEATURES

- Very low dissipation factor
- Highest peak pulse capability
- Design for Snubber Application
- Self-healing
- Soldering Terminal

## OVERVIEW

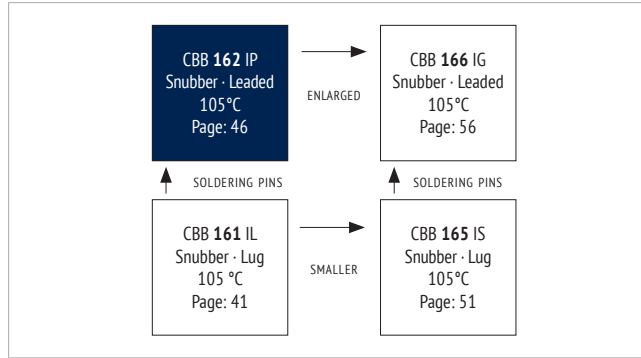

## PRODUCT



## APPLICATIONS

- High pulse and high frequency circuits
- IGBT applications

## CHARACTERISTICS

ITEM	CHARACTERISTICS
Climatic Category	40/105/56 (IEC 61071)
Operating Temperature	-40 ~ +105 °C ( $\theta_{hotspot} \leq 105$ °C) $\theta_{hotspot} = 85$ -105°C: See Voltage Derating Diagram
Storage Temperature	-40 ~ +105 °C
Rated Voltage $U_{RDC}$	630 ~ 2.000 V <sub>DC</sub>
Capacitance Range	0,001 ~ 1,8 $\mu$ F
Capacitance Tolerance	$\pm 10$ % (K), $\pm 5$ % (J)
Voltage between Terminals $U_{TT}$	$1,5 \cdot U_{RDC}$ (20°C, 10s)
Voltage between Terminals & Case $U_{TC}$	$\geq 3.000$ V <sub>AC</sub> (20°C, 50 Hz, 10s)
Capacitor Dissipation Factor $\tan \delta$	$\leq 5 \cdot 10^{-4}$ (20 °C, 1 kHz)
Dielectric Dissipation Factor $\tan \delta_e$	$\leq 2 \cdot 10^{-4}$ (20 °C, 1 kHz)
Insulation Resistance $R_i$ °C	$\geq 30.000$ M $\Omega \cdot \mu$ F (20 °C, 100 V <sub>DC</sub> , 1 min)
Max. Overvoltage	Please see IEC 61071
Life Time Expectancy	$\geq 100.000$ h, failure rate $\leq 100$ FIT (70°C)
Reference Standard	IEC 61071:2007

## ENVIRONMENTAL

The products are RoHS, WEEE and REACH compliant.

The detailed version please see separate "Environmental Certificates" document or [www.jianghai-europe.com](http://www.jianghai-europe.com)

## APPROVALS

UL94-V0:

Plastic & Compound Mass

## LIFETIME

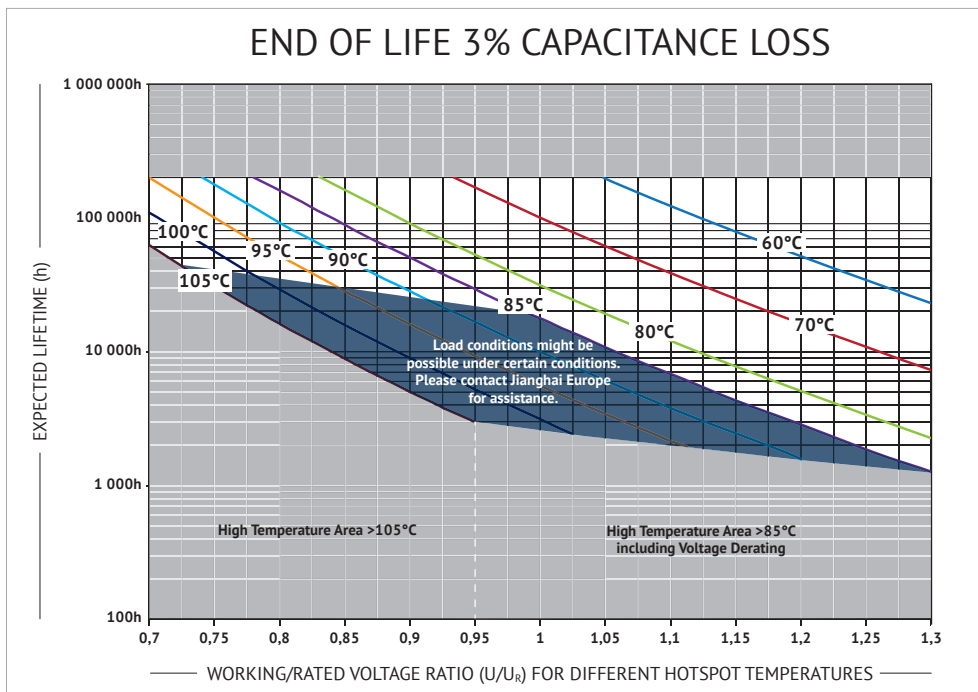

## VOLTAGE DERATING

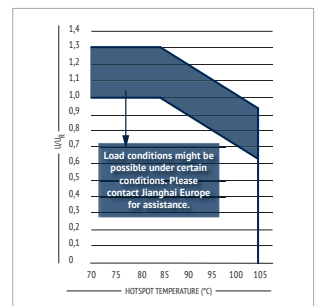

**DIMENSIONS**

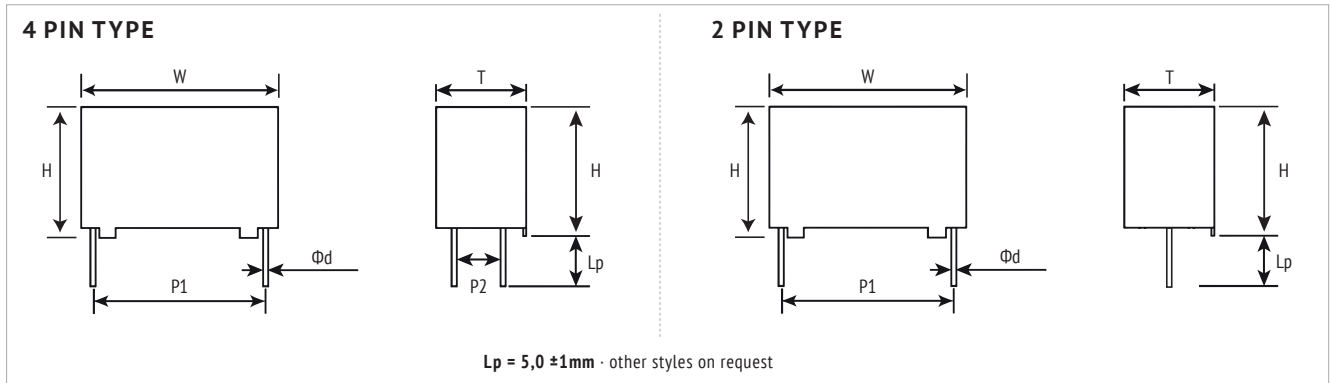

**INTERNAL CONSTRUCTION**

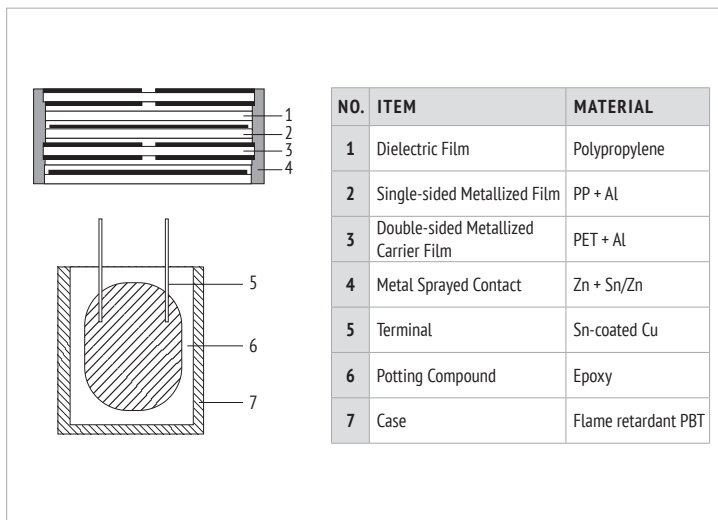

**MARKING**

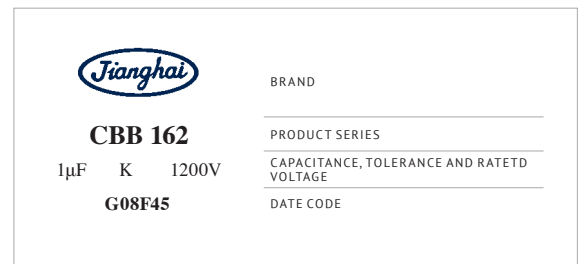

SNUBBER

**ORDER CODE**

FC	S	3B	IP	105	K	A	FA	37	20	C	E 3
Capacitor type	Product shape	DC rated voltage code (V)	Series code	Capacitance Code (µF)	Capacitance tolerance	Pin Style (mm)	Dimension Code (mm) W x H x T +1,0 +1,0 +1,0	Pitch P <sub>1</sub> (mm)	Pitch P <sub>2</sub> (mm)	Leadwire Diameter Ød	For internal use
Film Cap. - FC	Square box - S	630 <b>J2</b> 1000 <b>3A</b> 1200 <b>3B</b> 1600 <b>3C</b> 2000 <b>3D</b>	CBB 162 - IP	0,68 <b>684</b> 0,82 <b>824</b> 1,0 <b>105</b> 1,2 <b>125</b> 2,0 <b>205</b> 5,0 <b>505</b>	±5% <b>J</b> ±10% <b>K</b>	4 Pin Lp = 8mm <b>K</b> 4 Pin Lp = 5mm <b>A</b> 4 Pin Lp = 4,5mm <b>L</b> 4 Pin Lp = 4mm <b>S</b> 4 Pin Lp = 3,5mm <b>J</b> 2 Pin long leads (~20mm) <b>C</b> 2 Pin Lp = 5mm <b>B</b> 2 Pin Lp = 4,5mm <b>T</b> 2 Pin Lp = 4,0mm <b>M</b> 2 Pin Lp = 3,5mm <b>U</b> 2 Pin Lp = 3,2mm <b>V</b>	13 x 9 x 4 <b>C2</b> 13 x 11 x 5 <b>C4</b> 13 x 12 x 6 <b>C5</b> 13 x 13 x 7 <b>C8</b> 18 x 11 x 5 <b>E2</b> 18 x 12 x 6 <b>E5</b> 18 x 13,5 x 7,5 <b>E7</b> 18 x 14,5 x 8,5 <b>E8</b> 18 x 16 x 10 <b>EC</b> 18 x 19 x 11 <b>EG</b> 26,5 x 16,5 x 7 <b>B2</b> 26,5 x 17 x 8,5 <b>B3</b> 26,5 x 19 x 10 <b>B4</b> 26,5 x 20 x 11 <b>B5</b> 26,5 x 23 x 13 <b>B6</b> 32 x 20 x 11 <b>I4</b> 32 x 22 x 13 <b>I7</b> 32 x 24,5 x 13 <b>I8</b> 32 x 28 x 14 <b>IC</b> 32 x 33 x 18 <b>IF</b> 32 x 37 x 22 <b>II</b>	10 <b>10</b> 15 <b>15</b> 22,5 <b>22</b> 27,5 <b>27</b>	- <b>00</b> 5,1 <b>05</b> 10,2 <b>10</b> 12,7 <b>12</b> 20,3 <b>20</b>	0,6 <b>A</b> 0,8 <b>B</b> 1,0 <b>C</b> 1,2 <b>D</b> 0,5 <b>E</b>	





**RATINGS**

$U_R$ ≤85°C (V)	$C_R$ (μF)	dV/dt (V/μF)	$\hat{i}^{(1)}$ (A)	W +1/-1,5 (mm)	H +1/-1,5 (mm)	T +1/-1,5 (mm)	$P_1$ ±0,5 (mm)	$P_2$ ±0,5 (mm)	ød ±0,05 (mm)	ORDER CODE  *# to be defined, see ordering code table
630 V <sub>DC</sub> 420 V <sub>AC</sub> J2	0,0039	3000	11,7	13	9	4	10	-	0,6	FCSJ2IP392##C21000AE3
	0,0047	3000	14,1	13	9	4	10	-	0,6	FCSJ2IP472##C21000AE3
	0,0056	3000	16,8	13	9	4	10	-	0,6	FCSJ2IP562##C21000AE3
	0,0068	3000	20,4	13	9	4	10	-	0,6	FCSJ2IP682##C21000AE3
	0,0082	3000	24,6	13	9	4	10	-	0,6	FCSJ2IP822##C21000AE3
	0,010	3000	30,0	13	11	5	10	-	0,6	FCSJ2IP103##C41000AE3
	0,010	2500	25,0	18	11	5	15	-	0,8	FCSJ2IP103##E21500BE3
	0,012	2500	30,0	18	11	5	15	-	0,8	FCSJ2IP123##E21500BE3
	0,012	3000	36,0	13	11	5	10	-	0,6	FCSJ2IP123##C41000AE3
	0,015	2500	37,5	18	11	5	15	-	0,8	FCSJ2IP153##E21500BE3
	0,015	3000	45,0	13	12	6	10	-	0,6	FCSJ2IP153##C51000AE3
	0,018	2500	45,0	18	11	5	15	-	0,8	FCSJ2IP183##E21500BE3
	0,018	3000	54,0	13	12	6	10	-	0,6	FCSJ2IP183##C51000AE3
	0,020	2500	50,0	18	11	5	15	-	0,8	FCSJ2IP203##E21500BE3
	0,020	3000	60,0	13	13	7	10	-	0,6	FCSJ2IP203##C81000AE3
	0,022	3000	66,0	13	13	7	10	-	0,6	FCSJ2IP223##C81000AE3
	0,022	2500	55,0	18	11	5	15	-	0,8	FCSJ2IP223##E21500BE3
	0,027	2500	67,5	18	12	6	15	-	0,8	FCSJ2IP273##E51500BE3
	0,033	2500	82,5	18	12	6	15	-	0,8	FCSJ2IP333##E51500BE3
	0,039	2500	97,5	18	12	6	15	-	0,8	FCSJ2IP393##E51500BE3
	0,047	2500	117	18	13,5	7,5	15	-	0,8	FCSJ2IP473##E71500BE3
	0,056	2500	140	18	13,5	7,5	15	-	0,8	FCSJ2IP563##E71500BE3
	0,068	2500	170	18	14,5	8,5	15	-	0,8	FCSJ2IP683##E81500BE3
	0,082	2500	205	18	16	10	15	-	0,8	FCSJ2IP823##E81500BE3
	0,10	2500	250	18	16	10	15	-	0,8	FCSJ2IP104##EC1500BE3
	0,12	2500	300	18	19	11	15	-	0,8	FCSJ2IP124##EG1500BE3
	0,12	1500	180	26,5	16,5	7	22,5	-	0,8	FCSJ2IP124##B22000BE3
	0,15	1500	225	26,5	17	8,5	22,5	-	0,8	FCSJ2IP154##B32200BE3
	0,18	1500	270	26,5	17	8,5	22,5	-	0,8	FCSJ2IP184##B32200BE3
	0,22	1500	330	26,5	19	10	22,5	-	0,8	FCSJ2IP224##B42200BE3
	0,27	1500	405	26,5	20	11	22,5	-	0,8	FCSJ2IP274##B52200BE3
	0,33	1500	495	26,5	20	11	22,5	-	0,8	FCSJ2IP334##B52200BE3
	0,39	1500	585	26,5	23	13	22,5	-	0,8	FCSJ2IP394##B62200BE3
0,47	900	423	32	22	13	27,5	-5,1/10,2/12,7	0,8	FCSJ2IP474##I727##BE3	
0,56	900	504	32	22	13	27,5	-5,1/10,2/12,7	0,8	FCSJ2IP564##I727##BE3	
0,68	900	612	32	24,5	13	27,5	-5,1/10,2/12,7	0,8	FCSJ2IP684##I827##BE3	
0,82	900	738	32	28	14	27,5	-5,1/10,2/12,7	0,8	FCSJ2IP824##IC27##BE3	
1,0	900	900	32	33	18	27,5	-5,1/10,2/12,7	0,8	FCSJ2IP105##IF27##BE3	
1,2	900	1080	32	33	18	27,5	-5,1/10,2/12,7	0,8	FCSJ2IP125##IF27##BE3	
1,5	900	1350	32	37	22	27,5	-5,1/10,2/12,7	0,8	FCSJ2IP155##II27##BE3	
1,8	900	1620	32	37	22	27,5	-5,1/10,2/12,7	0,8	FCSJ2IP185##II27##BE3	
1000 V <sub>DC</sub> 500 V <sub>AC</sub> 3A	0,0039	3000	11,7	13	9	4	10	-	0,6	FCS3AIP392##C21000AE3
	0,0047	3000	14,1	13	9	4	10	-	0,6	FCS3AIP472##C21000AE3
	0,0056	3000	16,8	13	9	4	10	-	0,6	FCS3AIP562##C21000AE3
	0,0068	3000	20,4	13	9	4	10	-	0,6	FCS3AIP682##C21000AE3
	0,0082	3000	24,6	13	9	4	10	-	0,6	FCS3AIP822##C21000AE3
	0,010	2500	25,0	18	11	5	15	-	0,8	FCS3AIP103##E21500BE3
	0,010	3000	30,0	13	11	5	10	-	0,6	FCS3AIP103##C41000AE3
	0,012	2500	30,0	18	11	5	15	-	0,8	FCS3AIP123##E21500BE3
	0,012	3000	36,0	13	11	5	10	-	0,6	FCS3AIP123##C41000AE3
	0,015	2500	37,5	18	11	5	15	-	0,8	FCS3AIP153##E21500BE3
	0,015	3000	45,0	13	12	6	10	-	0,6	FCS3AIP153##C51000AE3
	0,018	2500	45,0	18	11	5	15	-	0,8	FCS3AIP183##E21500BE3
	0,018	3000	54,0	13	12	6	10	-	0,6	FCS3AIP183##C51000AE3
	0,020	2500	50,0	18	11	5	15	-	0,8	FCS3AIP203##E21500BE3
	0,020	3000	60,0	13	13	7	10	-	0,6	FCS3AIP203##C81000AE3
	0,022	3000	66,0	13	13	7	10	-	0,6	FCS3AIP223##C81000AE3
	0,022	2500	55,0	18	11	5	15	-	0,8	FCS3AIP223##E21500BE3
	0,027	2500	67,5	18	12	6	15	-	0,8	FCS3AIP273##E51500BE3
	0,033	2500	82,5	18	12	6	15	-	0,8	FCS3AIP333##E51500BE3
	0,039	2500	97,5	18	12	6	15	-	0,8	FCS3AIP393##E51500BE3
	0,047	2500	118	18	13,5	7,5	15	-	0,8	FCS3AIP473##E71500BE3
	0,056	2500	140	18	13,5	7,5	15	-	0,8	FCS3AIP563##E71500BE3
	0,068	2500	170	18	14,5	8,5	15	-	0,8	FCS3AIP683##E81500BE3

(1) Maximum permissible peak current

>>



$U_R$ ≤85°C (V)	$C_R$ (μF)	dV/dt (V/μF)	$\bar{I}^{(1)}$ (A)	W +1/-1,5 (mm)	H +1/-1,5 (mm)	T +1/-1,5 (mm)	$P_1$ ±0,5 (mm)	$P_2$ ±0,5 (mm)	ød ±0,05 (mm)	ORDER CODE  *# to be defined, see ordering code table
<b>1000 V<sub>DC</sub> 500 V<sub>AC</sub> 3A</b>	0,082	2500	205	18	16	10	15	-	0,8	FCS3AIP823##EC1500BE3
	0,10	2500	250	18	16	10	15	-	0,8	FCS3AIP104##EC1500BE3
	0,12	2500	300	18	19	11	15	-	0,8	FCS3AIP124##EG1500BE3
	0,12	1500	180	26,5	16,5	7	22,5	-	0,8	FCS3AIP124##B22200BE3
	0,15	1500	225	26,5	17	8,5	22,5	-	0,8	FCS3AIP154##B32200BE3
	0,18	1500	270	26,5	17	8,5	22,5	-	0,8	FCS3AIP184##B32200BE3
	0,22	1500	330	26,5	19	10	22,5	-	0,8	FCS3AIP224##B42200BE3
	0,27	1500	405	26,5	20	11	22,5	-	0,8	FCS3AIP274##B52200BE3
	0,33	1500	495	26,5	20	11	22,5	-	0,8	FCS3AIP334##B52200BE3
	0,39	1500	585	26,5	23	13	22,5	-	0,8	FCS3AIP394##B62200BE3
	0,47	900	423	32	22	13	27,5	-5,1/10,2/12,7	0,8	FCS3AIP474##I727##BE3
	0,56	900	504	32	22	13	27,5	-5,1/10,2/12,7	0,8	FCS3AIP564##I727##BE3
	0,68	900	612	32	24,5	13	27,5	-5,1/10,2/12,7	0,8	FCS3AIP684##I827##BE3
	0,82	900	738	32	28	14	27,5	-5,1/10,2/12,7	0,8	FCS3AIP824##IC27##BE3
	1,0	900	900	32	33	18	27,5	-5,1/10,2/12,7	0,8	FCS3AIP105##IF27##BE3
	1,2	900	1080	32	33	18	27,5	-5,1/10,2/12,7	0,8	FCS3AIP125##IF27##BE3
	1,5	900	1350	32	37	22	27,5	-5,1/10,2/12,7	0,8	FCS3AIP155##II27##BE3
	1,8	900	1620	32	37	22	27,5	-5,1/10,2/12,7	0,8	FCS3AIP185##II27##BE3
<b>1200 V<sub>DC</sub> 600 V<sub>AC</sub> 3B</b>	0,0012	4800	5,8	13	9	4	10	-	0,6	FCS3BIP122##C21000AE3
	0,0015	4800	7,2	13	9	4	10	-	0,6	FCS3BIP152##C21000AE3
	0,0018	4800	8,6	13	9	4	10	-	0,6	FCS3BIP182##C21000AE3
	0,0022	4800	10,6	13	9	4	10	-	0,6	FCS3BIP222##C21000AE3
	0,0027	4800	13,0	13	9	4	10	-	0,6	FCS3BIP272##C21000AE3
	0,0033	4800	15,8	13	9	4	10	-	0,6	FCS3BIP332##C21000AE3
	0,0039	4800	18,7	13	11	5	10	-	0,6	FCS3BIP392##C41000AE3
	0,0047	4800	22,6	13	11	5	10	-	0,6	FCS3BIP472##C41000AE3
	0,0056	4800	26,9	13	11	5	10	-	0,6	FCS3BIP562##C41000AE3
	0,0068	4800	32,6	13	11	5	10	-	0,6	FCS3BIP682##C41000AE3
	0,0082	4800	39,4	13	11	5	10	-	0,6	FCS3BIP822##C41000AE3
	0,010	3300	33,0	18	11	5	15	-	0,8	FCS3BIP103##E21500BE3
	0,012	3300	39,6	18	11	5	15	-	0,8	FCS3BIP123##E21500BE3
	0,015	3300	49,5	18	11	5	15	-	0,8	FCS3BIP153##E21500BE3
	0,018	3300	59,4	18	11	5	15	-	0,8	FCS3BIP183##E21500BE3
	0,020	3300	66,0	18	11	5	15	-	0,8	FCS3BIP203##E21500BE3
	0,022	3300	72,6	18	12	6	15	-	0,8	FCS3BIP223##E51500BE3
	0,027	3300	89,1	18	13,5	7,5	15	-	0,8	FCS3BIP273##E71500BE3
	0,033	3300	109	18	13,5	7,5	15	-	0,8	FCS3BIP333##E71500BE3
	0,039	3300	129	18	14,5	8,5	15	-	0,8	FCS3BIP393##E81500BE3
	0,047	2200	103	26,5	16,5	7	22,5	-	0,8	FCS3BIP473##B22200BE3
	0,056	2200	123	26,5	16,5	7	22,5	-	0,8	FCS3BIP563##B22200BE3
	0,068	2200	150	26,5	17	8,5	22,5	-	0,8	FCS3BIP683##B32200BE3
	0,082	2200	180	26,5	19	10	22,5	-	0,8	FCS3BIP823##B42200BE3
	0,10	2200	220	26,5	19	10	22,5	-	0,8	FCS3BIP104##B42200BE3
	0,12	2200	264	26,5	20	11	22,5	-	0,8	FCS3BIP124##B52200BE3
	0,15	2200	330	26,5	23	13	22,5	-	0,8	FCS3BIP154##B62200BE3
	0,18	1000	180	32	20	11	27,5	-5,1/10,2/12,7	0,8	FCS3BIP184##I427##BE3
	0,22	1000	220	32	22	13	27,5	-5,1/10,2/12,7	0,8	FCS3BIP224##I727##BE3
	0,27	1000	270	32	24,5	13	27,5	-5,1/10,2/12,7	0,8	FCS3BIP274##I827##BE3
	0,33	1000	330	32	28	14	27,5	-5,1/10,2/12,7	0,8	FCS3BIP334##IC27##BE3
	0,39	1000	390	32	33	18	27,5	-5,1/10,2/12,7	0,8	FCS3BIP394##IF27##BE3
0,56	1000	560	32	37	22	27,5	-5,1/10,2/12,7	0,8	FCS3BIP564##II27##BE3	
0,68	1000	680	32	37	22	27,5	-5,1/10,2/12,7	0,8	FCS3BIP684##II27##BE3	
<b>1600 V<sub>DC</sub> 650 V<sub>AC</sub> 3C</b>	0,0056	6000	33,6	18	11	5	15	-	0,8	FCS3CIP562##E21500BE3
	0,0068	6000	40,8	18	11	5	15	-	0,8	FCS3CIP682##E21500BE3
	0,0082	6000	49,2	18	11	5	15	-	0,8	FCS3CIP822##E21500BE3
	0,010	6000	60,0	18	11	5	15	-	0,8	FCS3CIP103##E21500BE3
	0,012	6000	72,0	18	12	6	15	-	0,8	FCS3CIP123##E51500BE3
	0,015	6000	90,0	18	12	6	15	-	0,8	FCS3CIP153##E51500BE3
	0,018	6000	108	18	13,5	7,5	15	-	0,8	FCS3CIP183##E71500BE3
	0,022	6000	132	18	13,5	7,5	15	-	0,8	FCS3CIP223##E71500BE3
	0,027	6000	162	18	14,5	8,5	15	-	0,8	FCS3CIP273##E81500BE3
	0,033	6000	198	18	14,5	8,5	15	-	0,8	FCS3CIP333##E81500BE3
	0,039	3000	117	26,5	16,5	7	22,5	-	0,8	FCS3CIP393##B22200BE3

SNUBBER

(1) Maximum permissible peak current



U <sub>R</sub> ≤85°C (V)	C <sub>R</sub> (µF)	dV/dt (V/µF)	I <sup>(1)</sup> (A)	W +1/-1,5 (mm)	H +1/-1,5 (mm)	T +1/-1,5 (mm)	P <sub>1</sub> ±0,5 (mm)	P <sub>2</sub> ±0,5 (mm)	ød ±0,05 (mm)	ORDER CODE  *# to be defined, see ordering code table
<b>1600 V<sub>DC</sub></b> <b>650 V<sub>AC</sub></b> <b>3C</b>	0,047	3000	141	26,5	16,5	7	22,5	-	0,8	FCS3CIP473##B22200BE3
	0,056	3000	168	26,5	17	8,5	22,5	-	0,8	FCS3CIP563##B32200BE3
	0,068	3000	204	26,5	19	10	22,5	-	0,8	FCS3CIP683##B42200BE3
	0,082	3000	246	26,5	19	10	22,5	-	0,8	FCS3CIP823##B42200BE3
	0,10	3000	300	26,5	20	11	22,5	-	0,8	FCS3CIP104##B52200BE3
	0,12	2000	240	32	22	13	27,5	-5,1/10,2/12,7	0,8	FCS3CIP124##I727##BE3
	0,15	2000	300	32	24,5	13	27,5	-5,1/10,2/12,7	0,8	FCS3CIP154##I827##BE3
	0,18	2000	360	32	28	14	27,5	-5,1/10,2/12,7	0,8	FCS3CIP184##IC27##BE3
	0,22	2000	440	32	33	18	27,5	-5,1/10,2/12,7	0,8	FCS3CIP224##IF27##BE3
	0,27	2000	540	32	33	18	27,5	-5,1/10,2/12,7	0,8	FCS3CIP274##IF27##BE3
	0,33	2000	660	32	33	18	27,5	-5,1/10,2/12,7	0,8	FCS3CIP334##IF27##BE3
	0,39	2000	780	32	37	22	27,5	-5,1/10,2/12,7	0,8	FCS3CIP394##II27##BE3
	0,47	2000	940	32	37	22	27,5	-5,1/10,2/12,7	0,8	FCS3CIP474##II27##BE3
	<b>2000 V<sub>DC</sub></b> <b>700 V<sub>AC</sub></b> <b>3D</b>	0,0010	9500	9,5	18	11	5	15	-	0,8
0,0012		9500	11,4	18	11	5	15	-	0,8	FCS3DIP122##E21500BE3
0,0015		9500	14,3	18	11	5	15	-	0,8	FCS3DIP152##E21500BE3
0,0018		9500	17,1	18	11	5	15	-	0,8	FCS3DIP182##E21500BE3
0,0022		9500	20,9	18	11	5	15	-	0,8	FCS3DIP222##E21500BE3
0,0027		9500	25,7	18	11	5	15	-	0,8	FCS3DIP272##E21500BE3
0,0033		9500	31,4	18	11	5	15	-	0,8	FCS3DIP332##E21500BE3
0,0039		9500	37,1	18	11	5	15	-	0,8	FCS3DIP392##E21500BE3
0,0047		9500	44,7	18	11	5	15	-	0,8	FCS3DIP472##E21500BE3
0,0056		9500	53,2	18	12	6	15	-	0,8	FCS3DIP562##E51500BE3
0,0068		9500	64,6	18	12	6	15	-	0,8	FCS3DIP682##E51500BE3
0,0082		9500	77,9	18	12	6	15	-	0,8	FCS3DIP822##E51500BE3
0,010		9500	95,0	18	13,5	7,5	15	-	0,8	FCS3DIP103##E71500BE3
0,012		9500	114	18	14,5	8,5	15	-	0,8	FCS3DIP123##E81500BE3
0,015		9500	143	18	14,5	8,5	15	-	0,8	FCS3DIP153##E81500BE3
0,018		9500	171	18	16	10	15	-	0,8	FCS3DIP183##EC1500BE3
0,022		3500	77,0	26,5	16,5	7	22,5	-	0,8	FCS3DIP223##B22200BE3
0,027		3500	94,5	26,5	16,5	7	22,5	-	0,8	FCS3DIP273##B22200BE3
0,033		3500	116	26,5	17	8,5	22,5	-	0,8	FCS3DIP333##B32200BE3
0,039		3500	137	26,5	19	10	22,5	-	0,8	FCS3DIP393##B42200BE3
0,047		3500	165	26,5	19	10	22,5	-	0,8	FCS3DIP473##B42200BE3
0,056		3500	196	26,5	20	11	22,5	-	0,8	FCS3DIP563##B52200BE3
0,068		2500	170	32	22	13	27,5	-5,1/10,2/12,7	0,8	FCS3DIP683##I727##BE3
0,082		2500	205	32	24,5	13	27,5	-5,1/10,2/12,7	0,8	FCS3DIP823##I827##BE3
0,10		2500	250	32	28	14	27,5	-5,1/10,2/12,7	0,8	FCS3DIP104##IC27##BE3
0,12		2500	300	32	33	18	27,5	-5,1/10,2/12,7	0,8	FCS3DIP124##IF27##BE3
0,15		2500	375	32	33	18	27,5	-5,1/10,2/12,7	0,8	FCS3DIP154##IF27##BE3
0,18		2500	450	32	37	22	27,5	-5,1/10,2/12,7	0,8	FCS3DIP184##II27##BE3
0,22		2500	550	32	37	22	27,5	-5,1/10,2/12,7	0,8	FCS3DIP224##II27##BE3

(1) Maximum permissible peak current

**SNUBBER**

## FEATURES

- Very low dissipation factor
- High peak pulse capability
- Plates for direct IGBT connection
- Self-healing
- 105°C

## OVERVIEW

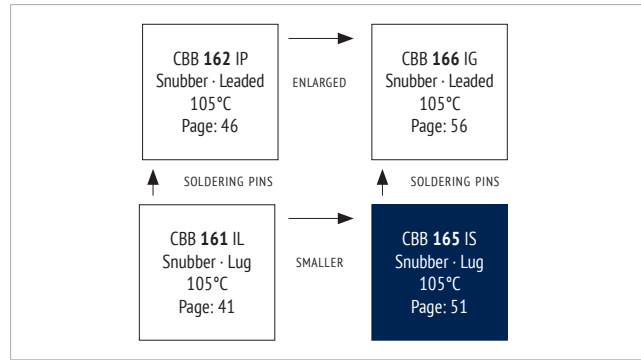

## PRODUCT



## APPLICATIONS

- High pulse and high frequency circuits

## CHARACTERISTICS

ITEM	CHARACTERISTICS
Climatic Category	40/105/56 (IEC 61071)
Operating Temperature	-40 ~ +105 °C ( $\theta_{hotspot} \leq 105$ °C) $\theta_{hotspot} = 85-105$ °C: See Voltage Derating Diagram
Storage Temperature	-40 ~ +105 °C
Rated Voltage $U_{RDC}$	850 ~ 3.000 V <sub>DC</sub>
Capacitance Range	0,4 ~ 8,0 $\mu$ F
Capacitance Tolerance	$\pm 10$ % (K), $\pm 5$ % (J)
Voltage between Terminals $U_{TT}$	$1,5 \cdot U_{RDC}$ (20 °C, 10s)
Voltage between Terminals & Case $U_{TC}$	3.000 V <sub>AC</sub> (20 °C, 50 Hz, 10s)
Capacitor Dissipation Factor $\tan \delta$	$\leq 5 \cdot 10^{-4}$ (20 °C, 1 kHz)
Dielectric Dissipation Factor $\tan \delta_d$	$\leq 2 \cdot 10^{-4}$ (20 °C, 1 kHz)
Series Inductance $L_s$ (typ.)	$\leq 20$ nH (20 °C)
Insulation Resistance $R_i \cdot C$	$\geq 10.000$ M $\Omega \cdot \mu$ F (20 °C, 100 V <sub>DC</sub> , 1 min)
Max. Overvoltage	Please see IEC 61071
Life Time Expectancy	$\geq 100.000$ h, failure rate $\leq 100$ FIT (70 °C)
Reference Standard	IEC 61071:2007

## ENVIRONMENTAL

The products are RoHS, WEEE and REACH compliant.

The detailed version please see separate "Environmental Certificates" document or [www.jianghai-europe.com](http://www.jianghai-europe.com)

## APPROVALS

UL94-V0:

Plastic & Compound Mass

## LIFETIME

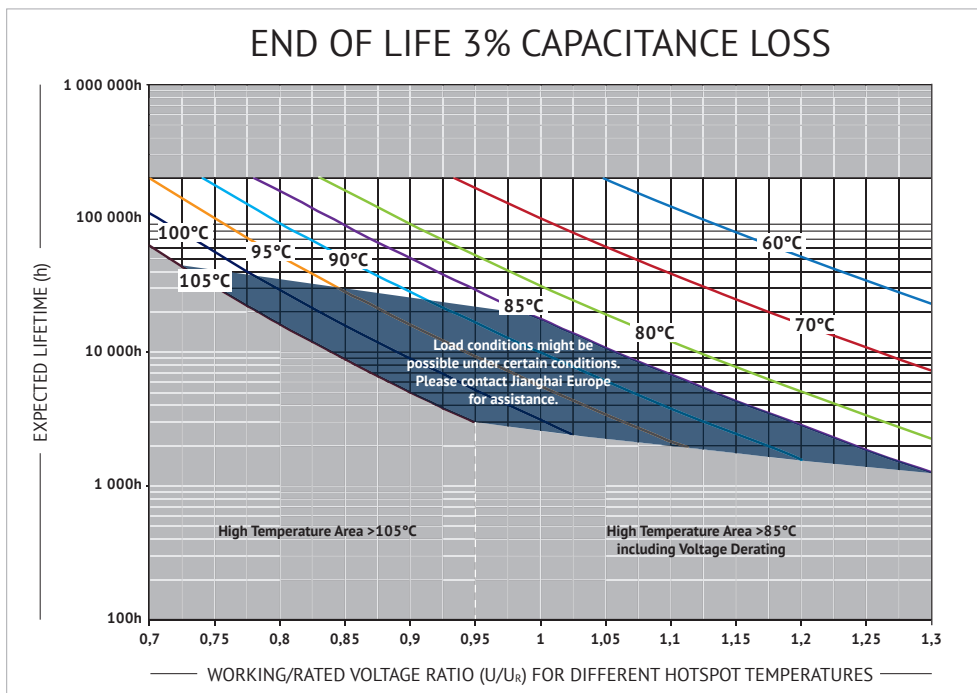

## CURRENT DERATING

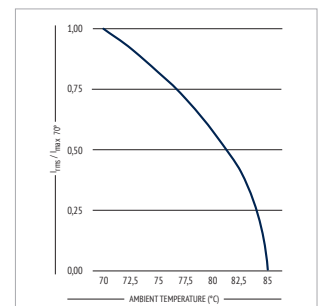

## VOLTAGE DERATING

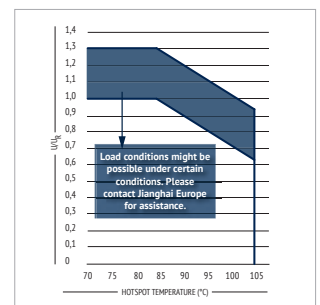

**DIMENSIONS**

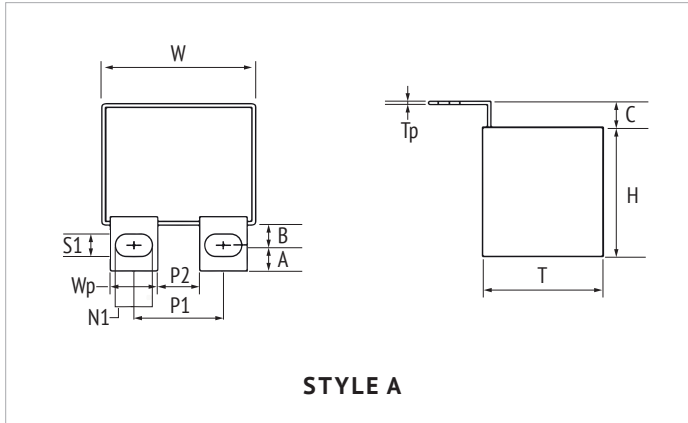

**STYLE A**

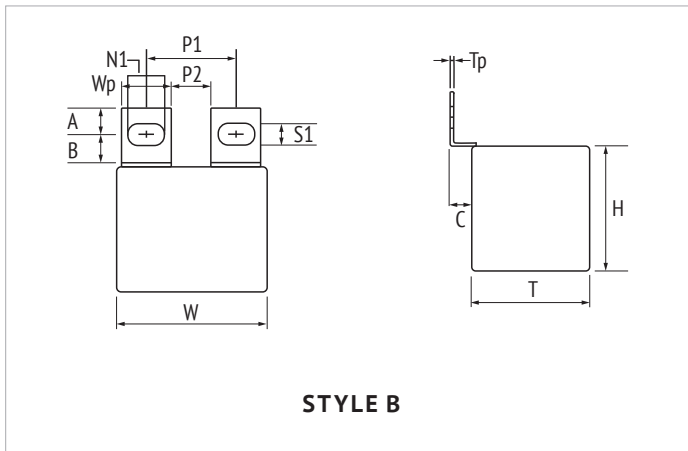

**STYLE B**

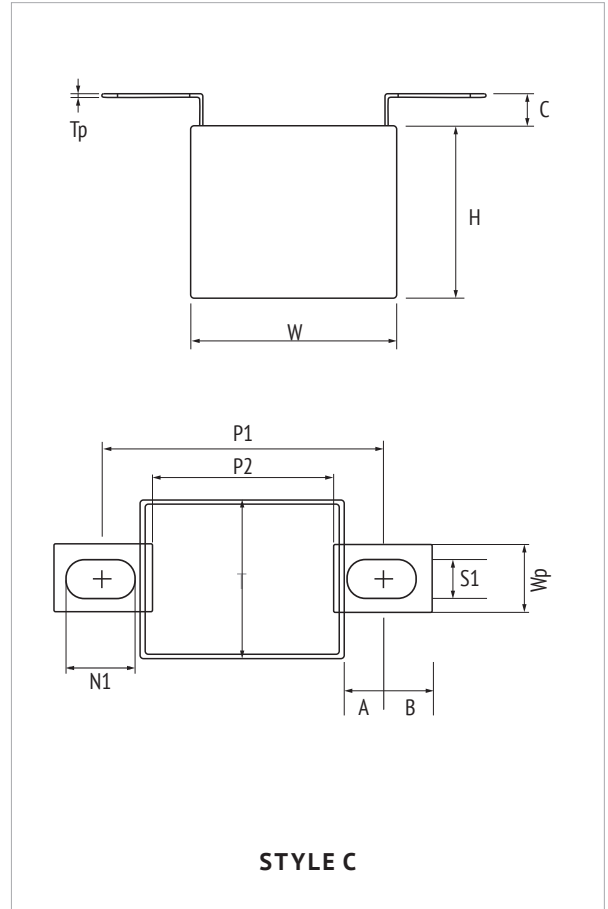

**STYLE C**

Terminal Style	Length of Case $W \pm 1/-1,5$ (mm)	Mounting Hole Pitch $P1 \pm 0,5$ (mm)	Gap between Terminals $P2 \pm 0,5$ (mm)	Width Terminal Plate $Wp \pm 0,3$ (mm)	Thickness Terminal $Tp \pm 0,1$ (mm)	Distance of Terminal $C \pm 1$ (mm)	Width of Hole $S1 \pm 0,1$ (mm)	Length of Hole $N1 \pm 0,3$ (mm)	Position of Hole $A \pm 0,2$ (mm)	Distance of Hole $B \pm 0,2$ (mm)
Style A/B	42,5	24,0	10,0	14,0	1,0	6,0	M6: 6,5 M8: 8,5	M6: 8,5 M8: 10,5	7,0	7,0
Style A/B	42,5	26,0	12,0	14,0	1,0	6,0	M6: 6,5 M8: 8,5	M6: 8,5 M8: 10,5	7,0	7,0
Style A/B	57,5	24,0	10,0	14,0	1,0	6,0	M6: 6,5 M8: 8,5	M6: 8,5 M8: 10,5	7,0	7,0
Style A/B	57,5	37,0	23,0	14,0	1,0	6,0	M6: 6,5 M8: 8,5	M6: 8,5 M8: 10,5	7,0	7,0
Style C	42,5	60,0	38,0	14,0	1,0	6,0	M8: 8,2	M8: 14	8,5	10,0
Style C	57,5	75,0	53,0	14,0	1,0	6,0	M8: 8,2	M8: 14	8,5	10,0

SNUBBER

## INTERNAL CONSTRUCTION

NO.	ITEM	MATERIAL
1	Single-sided Metallized Film	PP + Al
2	Metal Sprayed Contact	Zn + Sn/Zn
3	Terminal	Sn-coated Cu
4	Potting Compound	Epoxy
5	Case	Flame retardant PBT

## MARKING

**Jianghai** BRAND

**CBB 165** PRODUCT SERIES

1µF K 1200V CAPACITANCE, TOLERANCE AND RATED VOLTAGE

**G05F45** DATE CODE

## ORDER CODE

FC	S	3B	IL	105	K	A	FA	60	12	16	1	E 3
Capacitor type	Product shape	DC rated voltage code (V)	Series code	Capacitance Code (µF)	Capacitance tolerance	Plate Style (mm)	Dimension Code (mm)	Pitch P <sub>1</sub> (mm)	Gap P <sub>2</sub> (mm)	Width of plates W <sub>p</sub> (mm)	Hole Shape	For internal use
Film Cap. = FC	Square box = S	630 <b>2J</b> 700 <b>2Q</b> 850 <b>K2</b> 1000 <b>3A</b> 1200 <b>3B</b> 1600 <b>3C</b> 2000 <b>3D</b> 2500 <b>3E</b> 3000 <b>3F</b>	CBB 165 = IS	0,22 <b>224</b> 0,33 <b>334</b> 0,47 <b>474</b> 0,68 <b>684</b> 0,82 <b>824</b> 1,0 <b>105</b> 1,2 <b>125</b> 1,5 <b>155</b> 2,0 <b>205</b> 2,2 <b>225</b> 2,5 <b>255</b> 3,0 <b>305</b> 3,3 <b>335</b> 4,0 <b>405</b> 4,7 <b>475</b> 5,0 <b>505</b> 6,0 <b>605</b> 6,8 <b>685</b> 10,0 <b>106</b>	±5% <b>J</b> ±10% <b>K</b>	Style A <b>A</b> Style B <b>B</b> Style C <b>C</b>	42,5 x 28 x 24 <b>FA</b> 42,5 x 33 x 33 <b>FB</b> 42,5 x 35,5 x 33,5 <b>FC</b> 42,5 x 36 x 24 <b>FD</b> 42,5 x 43 x 42 <b>FE</b> 42,5 x 45 x 30 <b>FF</b> 57,5 x 43,5 x 29,5 <b>HG</b> 57,5 x 45 x 30 <b>HH</b> 57,5 x 45 x 35 <b>HJ</b> 57,5 x 45 x 45 <b>HK</b> 57,5 x 50 x 35 <b>HL</b> 57,5 x 55 x 40 <b>HM</b>	24 <b>24</b> 26 <b>26</b> 37 <b>37</b> 60 <b>60</b> 75 <b>75</b>	10 <b>10</b> 12 <b>12</b> 23 <b>23</b> 38 <b>38</b> 53 <b>53</b>	14 <b>14</b> <b>14</b>	Circular M6 <b>0</b> Oval M6: 6,5x8,5 <b>1</b> Circular M8 <b>2</b> Oval M8: 8,5x10,5 <b>3</b> Oval M6: 6,5x10,5 <b>7</b> Oval 9x12 <b>5</b> Circular ø5,5 <b>A</b> Circular ø7,0 <b>C</b> Circular ø5,0 <b>E</b> Oval 8,5x14,5 <b>D</b>	

SNUBBER



**RATINGS**

$U_R$	$C_R$	dV/dt	$\hat{i}^{(1)}$	ESR <sub>typ</sub>	$L_s$	$I_{max}$	W	H	T	ORDER CODE	
≤85°C		20°C		20°C 100kHz	20°C	70°C 100kHz	+1/-1,5	+1/-1,5	+1/-1,5	"*" to be defined, see ordering code table	
(V)	(μF)	(V/μS)	(A)	(mΩ)	(nH)	(A)	(mm)	(mm)	(mm)		
<b>850 V<sub>DC</sub></b> <b>450 V<sub>AC</sub></b> <b>K2</b>	1,20	375	450	10	≤20	11,8	42,5	28	24	FCSK2IS125##FA###14#E3	
	2,00	375	750	9	≤20	15,6	42,5	36	24	FCSK2IS205##FD###14#E3	
	2,50	375	937	8	≤20	17,6	42,5	35,5	33,5	FCSK2IS255##FC###14#E3	
	2,80	375	1050	7	≤20	19,8	42,5	35,5	33,5	FCSK2IS285##FC###14#E3	
	3,30	375	1237	6	≤20	21,5	42,5	45	30	FCSK2IS335##FF###14#E3	
	4,00	375	1500	5	≤20	24,0	42,5	43	42	FCSK2IS405##FE###14#E3	
	4,50	225	1012	5	≤20	24,0	57,5	43,5	29,5	FCSK2IS455##HG###14#E3	
	4,80	225	1080	4	≤20	25,0	57,5	45	30	FCSK2IS485##HH###14#E3	
	5,50	225	1237	4	≤20	25,0	57,5	45	35	FCSK2IS555##HJ###14#E3	
	6,50	225	1462	3	≤20	26,0	57,5	50	35	FCSK2IS655##HL###14#E3	
7,00	225	1575	3	≤20	26,0	57,5	45	45	FCSK2IS705##HK###14#E3		
8,00	225	1800	3	≤20	29,0	57,5	55	40	FCSK2IS805##HM###14#E3		
<b>1000 V<sub>DC</sub></b> <b>500 V<sub>AC</sub></b> <b>3A</b>	1,00	425	425	10	≤20	11,6	42,5	28	24	FCS3AIS105##FA###14#E3	
	1,50	425	637	9	≤20	15,5	42,5	36	24	FCS3AIS155##FD###14#E3	
	1,80	425	765	8	≤20	17,5	42,5	35,5	33,5	FCS3AIS185##FC###14#E3	
	2,00	425	850	7	≤20	18,8	42,5	35,5	33,5	FCS3AIS205##FC###14#E3	
	2,50	425	1062	6	≤20	21,0	42,5	45	30	FCS3AIS255##FF###14#E3	
	3,00	425	1275	5	≤20	23,0	42,5	43	42	FCS3AIS305##FE###14#E3	
	3,30	250	825	6	≤20	23,0	57,5	43,5	29,5	FCS3AIS335##HG###14#E3	
	3,50	250	875	5	≤20	24,0	57,5	45	30	FCS3AIS355##HH###14#E3	
	4,20	250	1050	5	≤20	24,0	57,5	45	35	FCS3AIS425##HJ###14#E3	
	4,80	250	1200	4	≤20	25,0	57,5	50	35	FCS3AIS485##HL###14#E3	
	5,00	250	1250	4	≤20	25,0	57,5	45	45	FCS3AIS505##HK###14#E3	
	6,00	250	1500	4	≤20	28,0	57,5	55	40	FCS3AIS605##HM###14#E3	
<b>1200 V<sub>DC</sub></b> <b>600 V<sub>AC</sub></b> <b>3B</b>	0,68	475	323	10	≤20	11,5	42,5	28	24	FCS3BIS684##FA###14#E3	
	1,00	475	475	10	≤20	15,4	42,5	36	24	FCS3BIS105##FD###14#E3	
	1,30	475	617	8	≤20	18,6	42,5	35,5	33,5	FCS3BIS135##FC###14#E3	
	1,60	475	760	7	≤20	20,6	42,5	45	30	FCS3BIS165##FF###14#E3	
	2,00	475	950	7	≤20	22,0	42,5	43	42	FCS3BIS205##FE###14#E3	
	2,20	300	660	6	≤20	22,0	57,5	43,5	29,5	FCS3BIS225##HG###14#E3	
	2,50	300	750	6	≤20	23,0	57,5	45	30	FCS3BIS255##HH###14#E3	
	2,80	300	840	6	≤20	24,0	57,5	45	35	FCS3BIS285##HJ###14#E3	
	3,30	300	990	5	≤20	24,0	57,5	50	35	FCS3BIS335##HL###14#E3	
	3,50	300	1050	5	≤20	25,0	57,5	45	45	FCS3BIS355##HK###14#E3	
	4,00	300	1200	5	≤20	26,0	57,5	55	40	FCS3BIS405##HM###14#E3	
	<b>1600 V<sub>DC</sub></b> <b>650 V<sub>AC</sub></b> <b>3C</b>	0,45	625	281	11	≤20	11,4	42,5	28	24	FCS3CIS454##FA###14#E3
		0,60	625	375	10	≤20	15,2	42,5	36	24	FCS3CIS604##FD###14#E3
0,70		625	437	10	≤20	17,0	42,5	35,5	33,5	FCS3CIS704##FC###14#E3	
0,85		625	531	9	≤20	18,4	42,5	35,5	33,5	FCS3CIS854##FC###14#E3	
1,00		625	625	8	≤20	20,5	42,5	45	30	FCS3CIS105##FF###14#E3	
1,30		625	812	7	≤20	21,0	42,5	43	42	FCS3CIS135##FE###14#E3	
1,50		375	562	6	≤20	22,0	57,5	43,5	29,5	FCS3CIS155##HG###14#E3	
1,60		375	600	6	≤20	22,0	57,5	45	30	FCS3CIS165##HH###14#E3	
1,80		375	675	5	≤20	23,0	57,5	45	35	FCS3CIS185##HJ###14#E3	
2,00		375	750	5	≤20	24,0	57,5	50	35	FCS3CIS205##HL###14#E3	
2,20		375	825	4	≤20	24,0	57,5	45	45	FCS3CIS225##HK###14#E3	
2,50		375	937	4	≤20	25,0	57,5	55	40	FCS3CIS255##HM###14#E3	
<b>2000 V<sub>DC</sub></b> <b>700 V<sub>AC</sub></b> <b>3D</b>		1,00	425	425	5	≤20	22,0	57,5	43,5	29,5	FCS3DIS105##HG###14#E3
		1,10	425	467	5	≤20	23,0	57,5	45	30	FCS3DIS115##HH###14#E3
	1,30	425	552	4	≤20	23,0	57,5	45	35	FCS3DIS135##HJ###14#E3	
	1,50	425	637	4	≤20	24,0	57,5	50	35	FCS3DIS155##HL###14#E3	
	1,70	425	722	4	≤20	25,0	57,5	45	45	FCS3DIS175##HK###14#E3	
	1,90	425	807	3	≤20	25,0	57,5	55	40	FCS3DIS195##HM###14#E3	
<b>2500 V<sub>DC</sub></b> <b>725 V<sub>AC</sub></b> <b>3E</b>	0,55	600	330	5	≤20	21,0	57,5	43,5	29,5	FCS3EIS554##HG###14#E3	
	0,60	600	360	5	≤20	21,0	57,5	45	30	FCS3EIS604##HH###14#E3	
	0,75	600	450	4	≤20	23,0	57,5	45	35	FCS3EIS754##HJ###14#E3	
	0,80	600	480	4	≤20	23,0	57,5	50	35	FCS3EIS804##HL###14#E3	
	0,90	600	540	3	≤20	24,0	57,5	45	45	FCS3EIS904##HK###14#E3	
	1,00	600	600	3	≤20	25,0	57,5	55	40	FCS3EIS105##HM###14#E3	

(1) Maximum permissible peak current





$U_R$	$C_R$	dV/dt	$\hat{I}^{(1)}$	ESR <sub>typ</sub>	$L_S$	$I_{max}$	W	H	T	ORDER CODE
≤85°C		20°C		20°C	20°C	70°C	+1/-1,5	+1/-1,5	+1/-1,5	"#" to be defined, see ordering code table
(V)	(μF)	(V/μS)	(A)	(mΩ)	(nH)	(A)	(mm)	(mm)	(mm)	
3000 V <sub>DC</sub> 750 V <sub>AC</sub> 3L	0,40	600	240	6	≤20	21,0	57,5	43,5	29,5	FCS3LIS404##HG###14#E3
	0,40	600	240	6	≤20	21,0	57,5	45	30	FCS3LIS404##HH###14#E3
	0,50	600	300	5	≤20	22,0	57,5	45	35	FCS3LIS504##HJ###14#E3
	0,55	600	330	5	≤20	23,0	57,5	50	35	FCS3LIS554##HL###14#E3
	0,65	600	390	4	≤20	23,0	57,5	45	45	FCS3LIS654##HK###14#E3
	0,70	600	420	4	≤20	24,0	57,5	55	40	FCS3LIS704##HM###14#E3

(1) Maximum permissible peak current

SNUBBER



## FEATURES

- Very low dissipation factor
- Highest peak pulse capability
- Design for Snubber Application
- Self-healing
- Soldering Terminal

## OVERVIEW

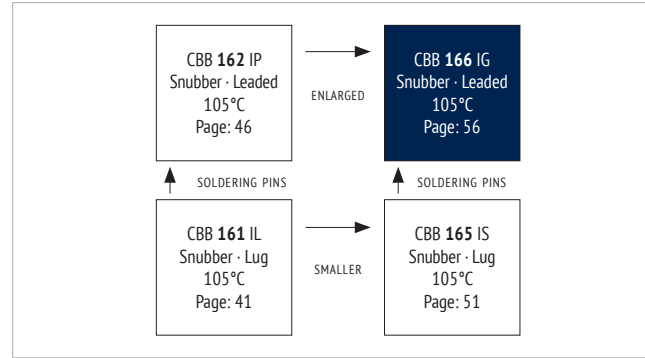

## PRODUCT



## APPLICATIONS

- High pulse and high frequency circuits
- IGBT applications

## CHARACTERISTICS

ITEM	CHARACTERISTICS
Climatic Category	40/105/56 (IEC 61071)
Operating Temperature	-40 ~ +105 °C ( $\Theta_{hotspot} \leq 105$ °C) $\Theta_{hotspot} = 85-105$ °C: See Voltage Derating Diagram
Storage Temperature	-40 ~ +105 °C
Rated Voltage $U_{RDC}$	850 ~ 2.000 V <sub>DC</sub>
Capacitance Range	0,033 ~ 5,0 µF
Capacitance Tolerance	±10 % (K), ±5 % (J)
Voltage between Terminals $U_{TT}$	1,5 * $U_{RDC}$ (20 °C, 10s)
Voltage between Terminals & Case $U_{TC}$	≥ 3.000 V <sub>AC</sub> (20 °C, 50 Hz, 10s)
Capacitor Dissipation Factor $\tan \delta$	≤ 1 * 10 <sup>-3</sup> (20 °C, 1 kHz)
Dielectric Dissipation Factor $\tan \delta_0$	≤ 2 * 10 <sup>-4</sup> (20 °C, 1 kHz)
Insulation Resistance $R_i$ °C	≥ 10.000 MΩ * µF (20 °C, 100 V <sub>DC</sub> , 1 min)
Max. Overvoltage	Please see IEC 61071
Life Time Expectancy	≥ 100.000h, failure rate ≤ 100 FIT (70 °C)
Reference Standard	IEC 61071:2007

## ENVIRONMENTAL

The products are RoHS, WEEE and REACH compliant.

The detailed version please see separate "Environmental Certificates" document or [www.jianghai-europe.com](http://www.jianghai-europe.com)

## APPROVALS

**UL94-V0:**  
Plastic & Compound Mass

SNUBBER

## LIFETIME

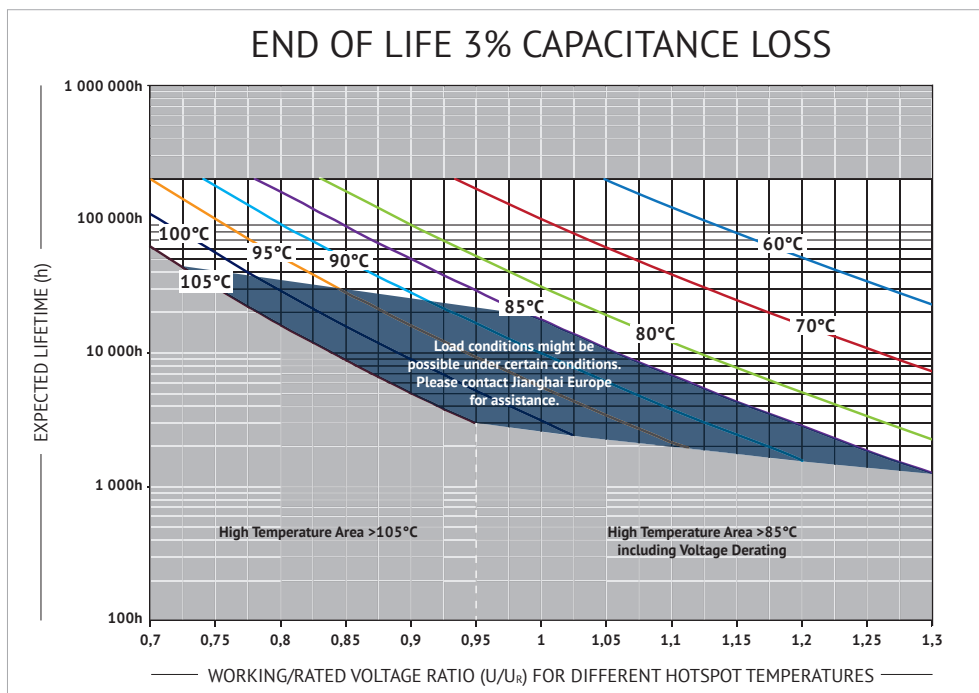

## CURRENT DERATING

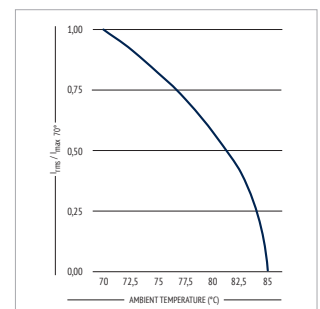

## VOLTAGE DERATING

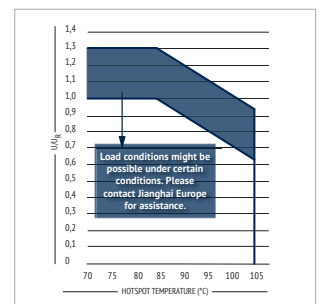

**DIMENSIONS**

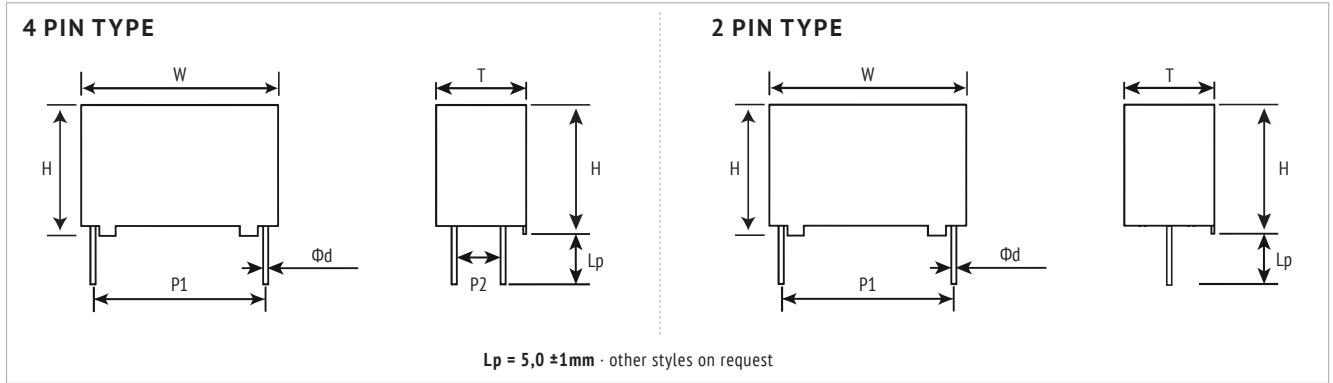

**INTERNAL CONSTRUCTION**

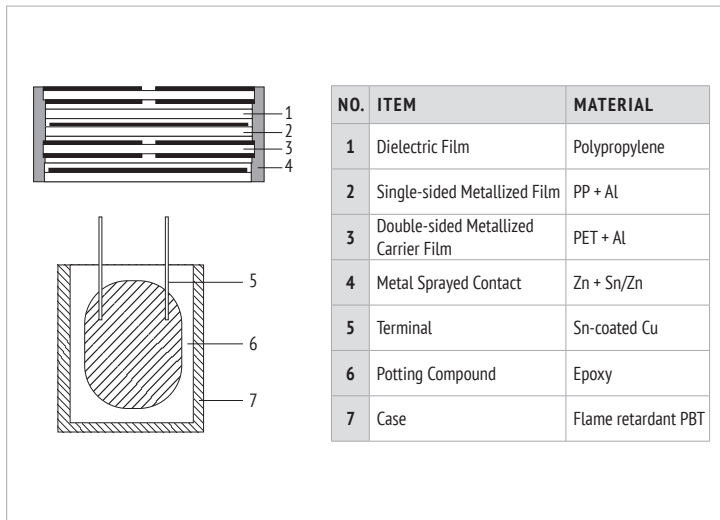

**MARKING**

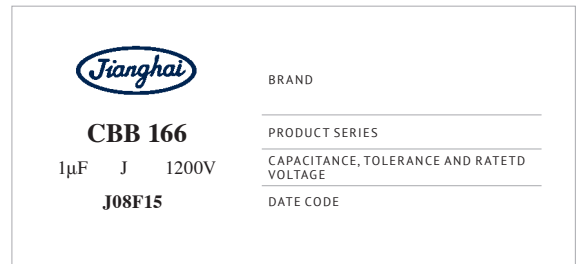

SNUBBER

**ORDER CODE**

FC	S	3B	IG	105	K	A	FA	37	20	C	E 3
Capacitor type	Product shape	DC rated voltage code (V)	Series code	Capacitance Code (μF)	Capacitance tolerance	Pin Style (mm)	Dimension Code (mm) W x H x T +1,0 +1,0 +1,0	Pitch P <sub>1</sub> (mm)	Pitch P <sub>2</sub> (mm)	Leadwire Diameter Ød	For internal use
Film Cap. - FC	Square box - S	850 <b>K2</b> 1000 <b>3A</b> 1200 <b>3B</b> 1600 <b>3C</b> 2000 <b>3D</b>	CBB 166 - IG	0,033 <b>333</b> 0,68 <b>684</b> 0,82 <b>824</b> 1,0 <b>105</b> 1,2 <b>125</b> 2,0 <b>205</b> 5,0 <b>505</b>	±5% <b>J</b> ±10% <b>K</b>	4 Pin Lp = 8mm <b>K</b> 4 Pin Lp = 5mm <b>A</b> 4 Pin Lp = 4,5mm <b>L</b> 4 Pin Lp = 4mm <b>S</b> 4 Pin Lp = 3,5mm <b>J</b> 2 Pin long leads (~ 20mm) <b>C</b> 2 Pin Lp = 5mm <b>B</b> 2 Pin Lp = 4,5mm <b>T</b> 2 Pin Lp = 4,0mm <b>M</b> 2 Pin Lp = 3,5mm <b>U</b> 2 Pin Lp = 3,2mm <b>V</b>	32 x 20 x 11 <b>I4</b> 32 x 22 x 13 <b>I7</b> 32 x 24,5 x 13 <b>I8</b> 32 x 28 x 14 <b>IC</b> 32 x 33 x 18 <b>IF</b> 32 x 37 x 22 <b>II</b> 42,5 x 37 x 28 <b>F1</b> 42,5 x 40 x 20 <b>F2</b> 42,5 x 32 x 19 <b>F5</b> 42,5 x 44 x 24 <b>F9</b> 42,5 x 45 x 30 <b>FF</b> 57,5 x 45 x 30 <b>HH</b> 57,5 x 50 x 35 <b>HL</b>	27,5 <b>27</b> 37,5 <b>37</b> 52,5 <b>52</b>	10,2 <b>10</b> 20,3 <b>20</b> - <b>00</b>	0,6 <b>A</b> 0,8 <b>B</b> 1,0 <b>C</b> 1,2 <b>D</b> 0,5 <b>E</b>	

**RATINGS**

Table with columns: U\_R, C\_R, I\_max (70°C, 60°C, ≤50°C), f(1), ESR\_op, R\_th(2), dV/dt, L\_s, W, H, T, P\_1, P\_2, ød, ORDER CODE. Rows include ratings for 850 V\_DC, 1000 V\_DC, 1200 V\_DC, 1600 V\_DC, and 2000 V\_DC with various AC voltage and current ratings.

SNUBBER

(1) Maximum permissible peak current, (2) Thermal resistance from hotspot to ambient (free convection)



FEATURES

- Customer Specific Designs
- High ripple current capability
- Self-healing
- Long lifetime
- Metal Case, fire retardant resin

OVERVIEW

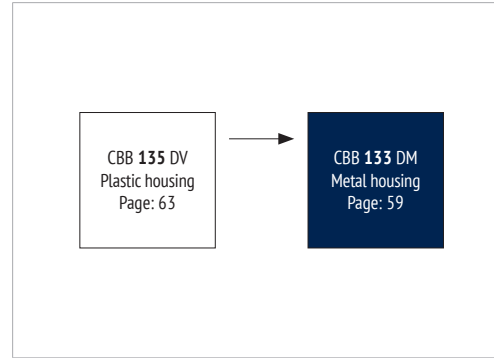

PRODUCT



APPLICATIONS

- High power frequency converters
- Electric and hybrid electric vehicles, Traction and Trains

CHARACTERISTICS

ITEM	CHARACTERISTICS
Climatic Category	40/85/56 (IEC 61071)
Operating Temperature	-40 ~ +70 °C ( $\theta_{hotspot} \leq 85$ °C)
Storage Temperature	-40 ~ +85 °C
Rated Voltage $U_{RDC}$	750 ~ 3.000 $V_{DC}$
Capacitance Range	500 ~ 65.000 $\mu F$
Capacitance Tolerance	$\pm 10$ % (K), $\pm 5$ % (J)
Voltage between Terminals $U_{TT}$	$1,5 \cdot U_{RDC}$ (20°C, 10s)
Voltage between Terminals & Case $U_{TC}$	$\geq 3.000 V_{AC}$ (20°C, 50 Hz, 10s)
Max. Overvoltage	Please see IEC 61071
Insulation Resistance $R_i$ , °C	$\geq 5.000 M\Omega \cdot \mu F$ (20 °C, 100 $V_{DC}$ , 1 min)
Dielectric Dissipation Factor $\tan \delta_0$	$\leq 2 \cdot 10^{-4}$ (20 °C, 100 Hz)
Life Time Expectancy	100.000h, failure rate $\leq 100$ FIT ( $\theta_{hotspot} \leq 70$ °C, $U_{RDC}$ )
Reference Standard	IEC 61071:2007

ENVIRONMENTAL

The products are RoHS, WEEE and REACH compliant.  
The detailed version please see separate "Environmental Certificates" document or [www.jianghai-europe.com](http://www.jianghai-europe.com)

APPROVALS

- UL94-V0:**  
Plastic & Compound Mass
- UL810:**  
CZDS2.E227010 (Construction)  
(customized on request)

LIFETIME

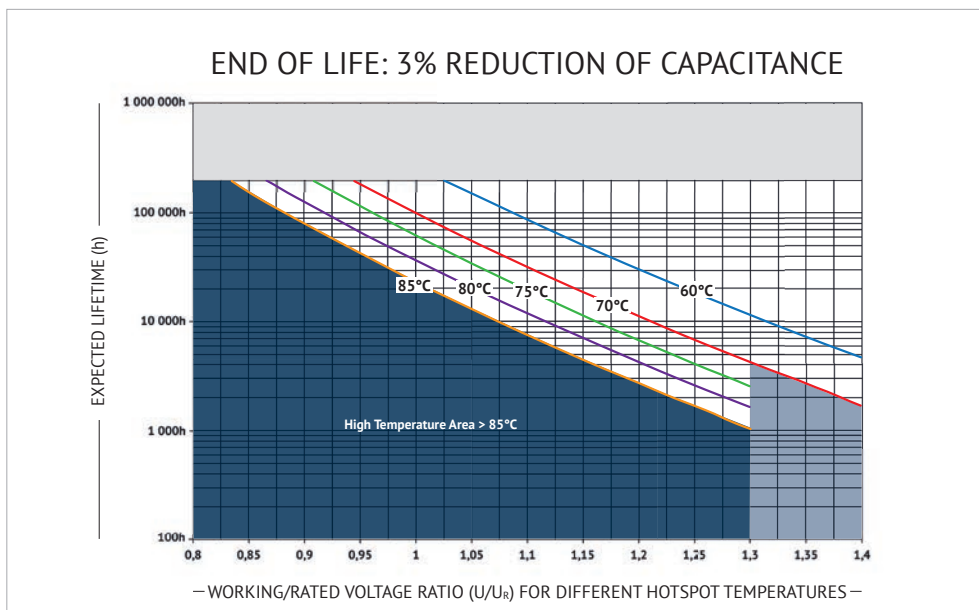

MODULES



EXAMPLE DRAWING #1

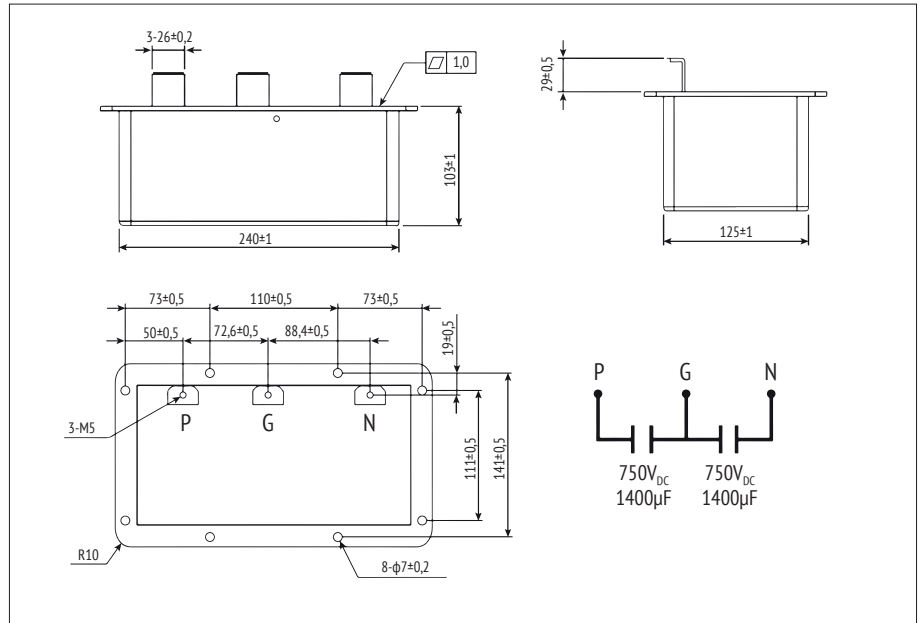

EXAMPLE DRAWING #2

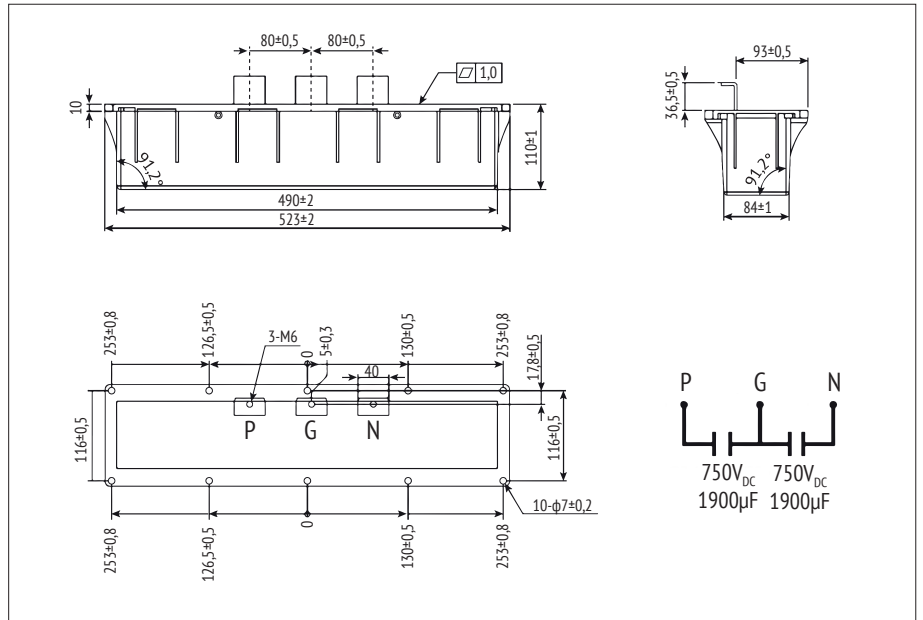

EXAMPLE DRAWING #3

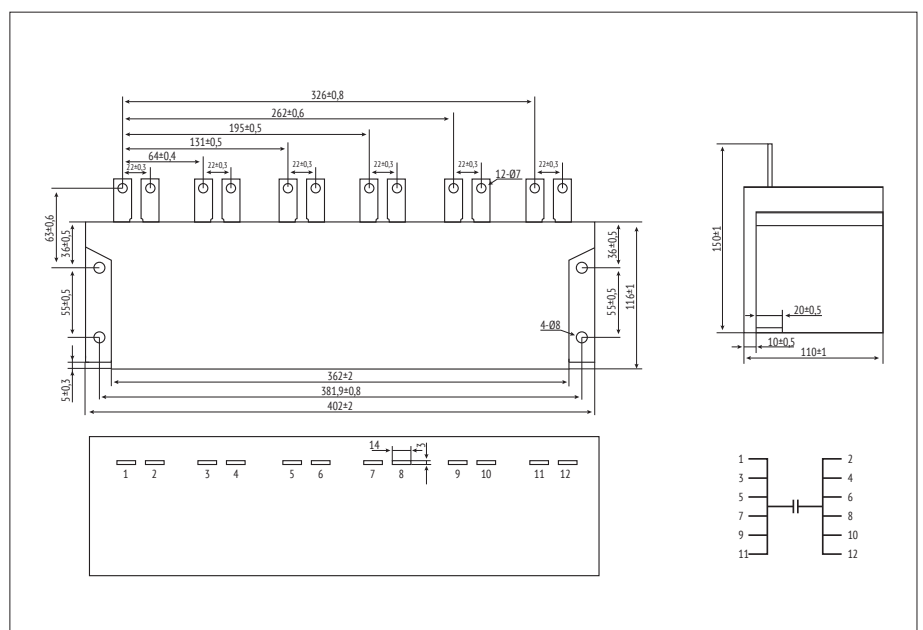

MODULES

in mm



EXAMPLE DRAWING #4

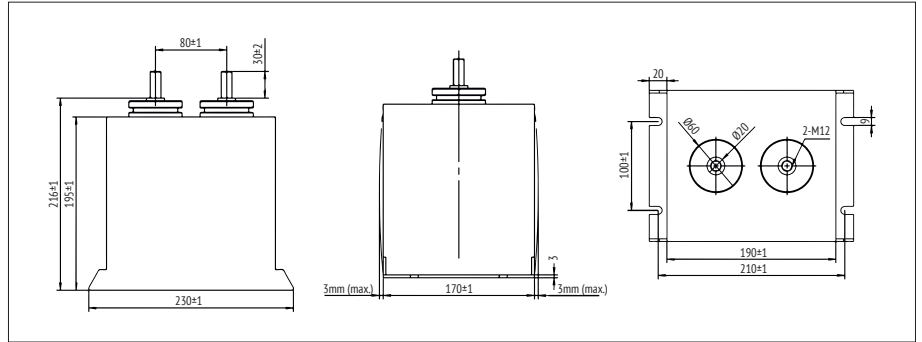

EXAMPLE DRAWING #5

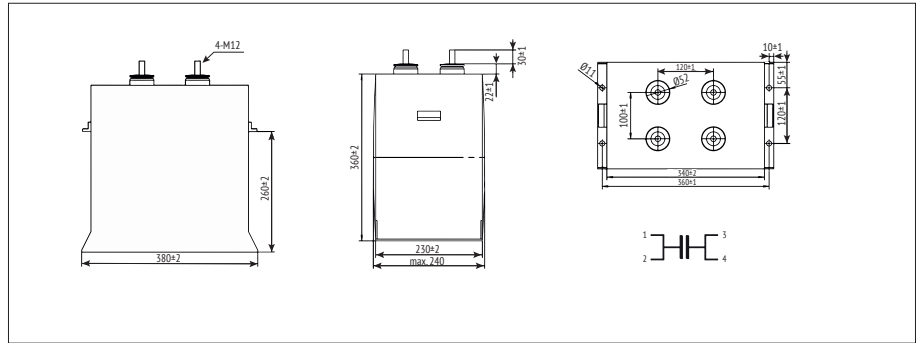

EXAMPLE DRAWING #6

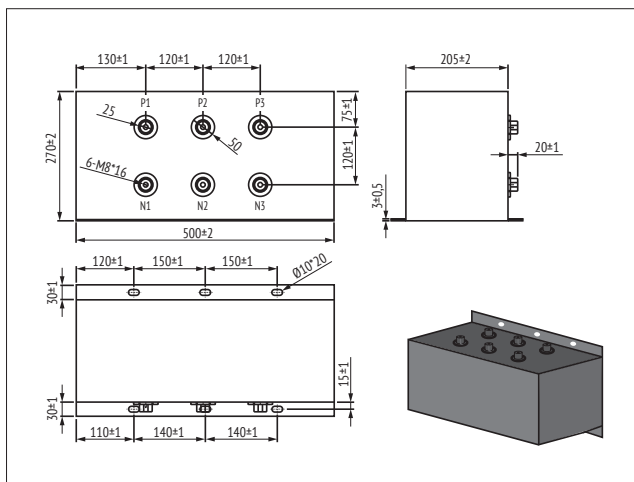

EXAMPLE DRAWING #7

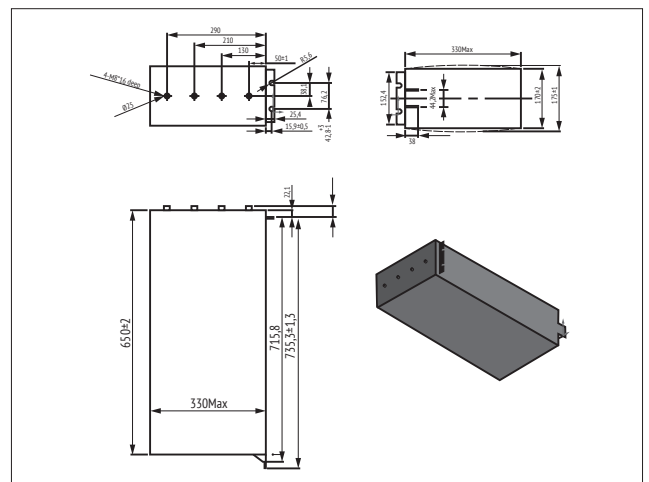

EXAMPLE DRAWING #8

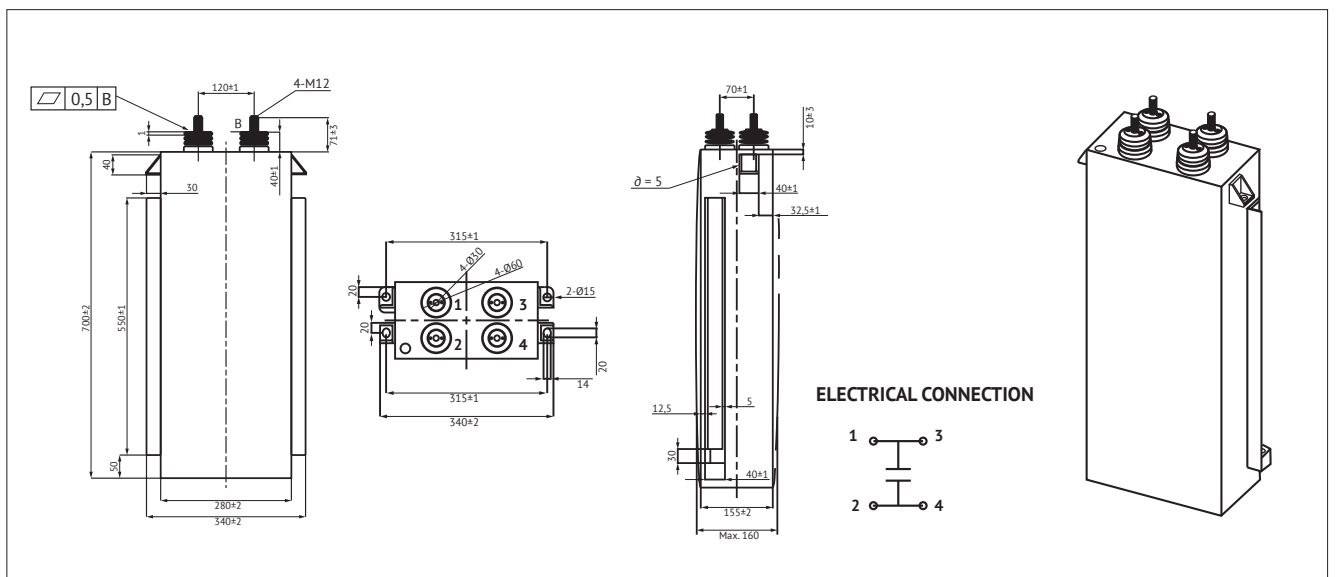



## MARKING

	BRAND
<b>CBB 133</b>	SERIES DESIGNATION
2500 $\mu$ F $\pm$ 10%	CAPACITANCE AND TOLERANCE
$U_R = 800V_{DC} SH$	$U_R$ RATED VOLTAGE
$U_{TC} = 3000V 50/60 HZ$	$U_{TC}$ VOLTAGE BETWEEN TERMINALS AND CASE, FREQUENCY
-40~+85°C IEC61071	TEMPERATURE RANGE, REFERENCE STANDARD
Discharge before handling	SAFETY WARNING
J35F23104	DATE CODE

## ORDER CODE

FC	S	2K	DM	158	K	024010013	E3
Capacitor type	Product shape	DC rated voltage code (V)	Series code	Capacitance Code Examples ( $\mu$ F)	Capacitance tolerance	Dimension Code	For internal use
Film Cap. = FC	Square box = S	750 <b>Q3</b> 800 <b>2K</b> 900 <b>R2</b> 950 <b>K3</b> 1020 <b>3A</b> 1100 <b>A3</b> 1200 <b>3B</b> 2250 <b>3T</b> 2500 <b>3E</b> 3000 <b>3F</b>	CBB 133 = DM	1500 <b>158</b> 2800 <b>288</b> 13500 <b>139</b>	$\pm$ 5% <b>J</b> $\pm$ 10% <b>K</b>	0 2 4 0 1 0 0 1 3	

## RATINGS

$U_R$ ( $V_{DC}$ )	$C_R$ ( $\mu$ F)	$I_{MAX}$ 60°C 10kHz (A)	$\hat{I}^{(1)}$ (A)	ESR <sub>typ</sub> 20°C 10kHz (m $\Omega$ )	$L_s$ 20°C (nH)	W (mm)	H (mm)	T (mm)	ORDER CODE
750 Q3	2800	80	2200	0,8	80	240	103	125	FCSQ3DM288K024010013E3
	3800	80	3800	0,6	80	490	110	84	FCSQ3DM388K049011009E3
800 2K	2500	250	3500	0,6	50	190	195	170	FCS2KDM258K019020017E3
	2500	300	3500	0,4	50	402	116	110	FCS2KDM258K040012011E3
900   R2	18000	400	3600	0,7	50	500	460	120	FCSR2DM189K050046012E3
950 K3	3 x 2500	3 x 135	3 x 8400	3 x 1,5	50	500	205	270	FCSK3DM258J050021027E3
	2 x 3750	2 x 140	2 x 6200	2 x 1,2	50	500	205	270	FCSK3DM758J050021027E3
1020   3A	13500	300	5050	0,5	60	330	650	170	FCS3ADM139K033065017E3
1100   A3	900	100	9000	1	80	163	152	162	FCSA3DM907K016015016E3
1200 3B	8000	260	6000	0,5	80	620	200	140	FCS3BDM808K062020014E3
	9000	500	18.000	1,2	50	680	210	230	FCS3BDM908J068021023E3
	20.000	250	100.000	1	50	280	700	155	FCS3BDM209S028070016E3
	65.000	400	100.000	1	50	460	880	185	FCS3BDM659S046088019E3
2250   3T	4000	400	19.000	0,5	60	340	175	670	FCS3TDM408J034018067E3
2500   3E	30.000	100	90.000	0,8	100	395	1170	220	FCS3EDT309K040117022E3
3000   3F	1500	150	4000	1	100	340	360	230	FCS3FDM158J034036023E3

(1) Maximum permissible peak current



## FEATURES

- Customer Specific Designs
- High ripple current capability
- Self-healing
- Long lifetime

## OVERVIEW

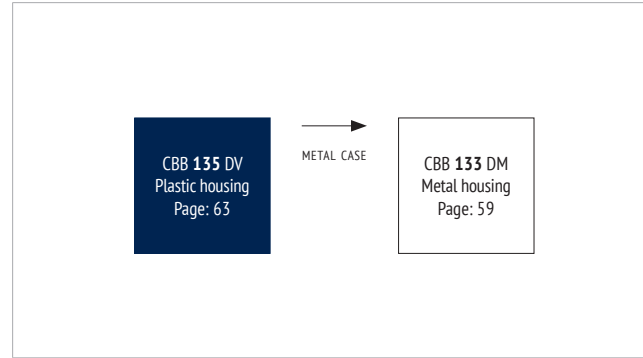

## PRODUCT



## APPLICATIONS

- High power frequency converters
- Electric and hybrid electric vehicles

## CHARACTERISTICS

ITEM	CHARACTERISTICS
Climatic Category	40/105/56 (IEC 61071)
Operating Temperature	-40 ~ +105 °C ( $\Theta_{\text{hotspot}} \leq 105$ °C) $\Theta_{\text{hotspot}} = 85-105$ °C: See Voltage Derating Diagram
Storage Temperature	-40 ~ +105 °C
Rated Voltage $U_{\text{RDC}}$	450 ~ 800 $V_{\text{DC}}$
Capacitance Range	300 ~ 1.000 $\mu\text{F}$
Capacitance Tolerance	$\pm 10$ % (K), $\pm 5$ % (J)
Voltage between Terminals $U_{\text{TT}}$	$1,5 * U_{\text{RDC}}$ (20°C, 10s)
Voltage between Terminals and Case $U_{\text{TC}}$	$\geq 3.000 V_{\text{AC}}$ (20°C, 50 Hz, 10s)
Max. Overvoltage	$1,1 * U_{\text{RDC}}$ (30 % of time under load) $1,15 * U_{\text{RDC}}$ (30 min. per day) $1,2 * U_{\text{RDC}}$ (5 min. per day) $1,3 * U_{\text{RDC}}$ (1 min. per day) $1,5 * U_{\text{RDC}}$ (max. 30 ms, 100ms per day)
Insulation Resistance $R_i$ °C	$\geq 10.000 M\Omega * \mu\text{F}$ (20 °C, 100 $V_{\text{DC}}$ , 1 min)
Dielectric Dissipation Factor $\tan \delta_0$	$\leq 2 * 10^{-4}$ (20 °C, 1 kHz)
Life Time Expectancy	100.000h, failure rate 100 FIT ( $\Theta_{\text{hotspot}} 70$ °C, $U_{\text{RDC}}$ )
Reference Standard	IEC 61071:2007

## ENVIRONMENTAL

The products are RoHS, WEEE and REACH compliant.

The detailed version please see separate "Environmental Certificates" document or [www.jianghai-europe.com](http://www.jianghai-europe.com)

## APPROVALS

### UL94-V0:

Plastic & Compound Mass

### UL810:

CZDS2.E227010  
(Construction)

(customized on request)

## LIFETIME

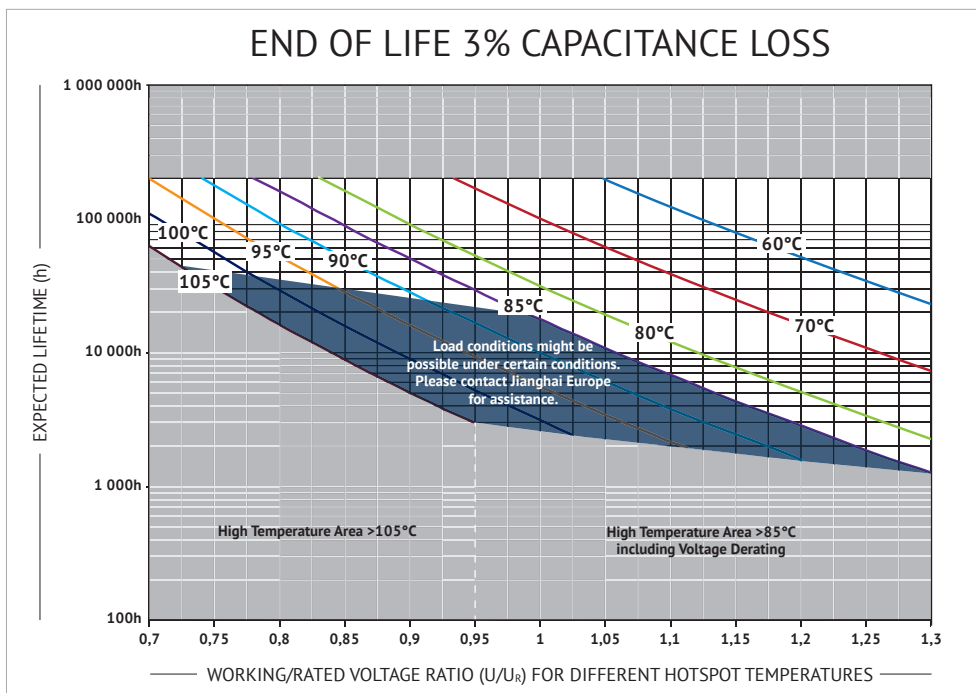

## VOLTAGE DERATING

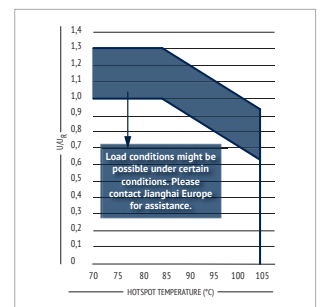





MARKING

	BRAND
<b>CBB 135</b>	SERIES DESIGNATION
500 $\mu$ F $\pm$ 10%	CAPACITANCE AND TOLERANCE
$U_R = 800V_{dc}SH$	$U_R$ RATED VOLTAGE
$U_{TC} = 3000V$ 50/60 HZ	$U_{TC}$ VOLTAGE BETWEEN TERMINALS AND CASE, FREQUENCY
-40~+105°C IEC61071	TEMPERATURE RANGE, REFERENCE STANDARD
Discharge before handling	SAFETY WARNING
E03F0310	DATE CODE

EXAMPLE DRAWING #1

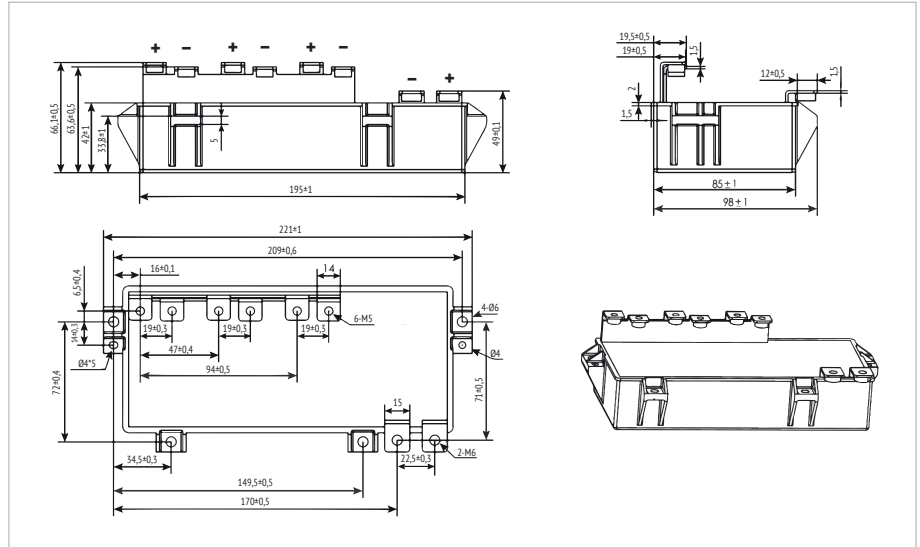

EXAMPLE DRAWING #2

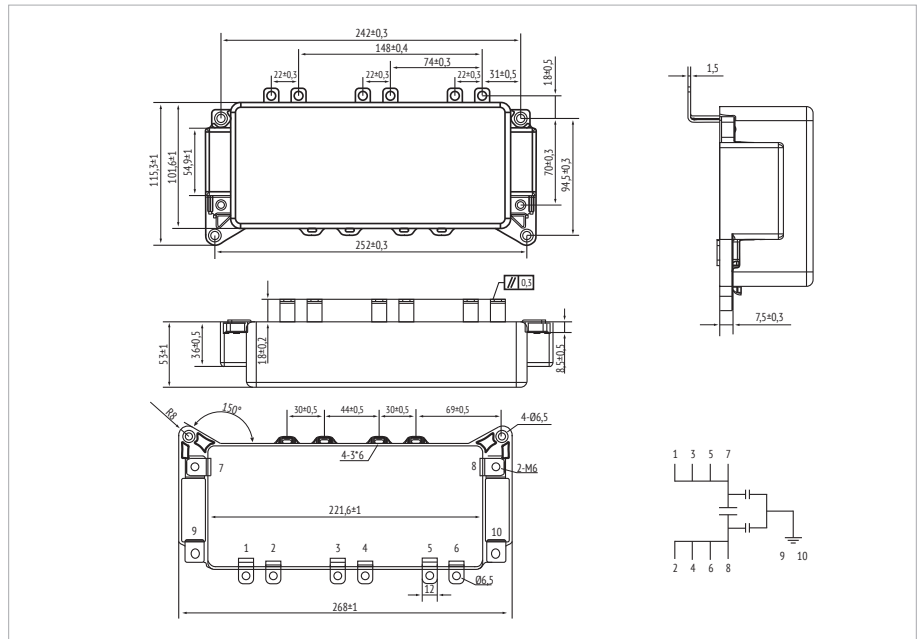

in mm



EXAMPLE DRAWING #3

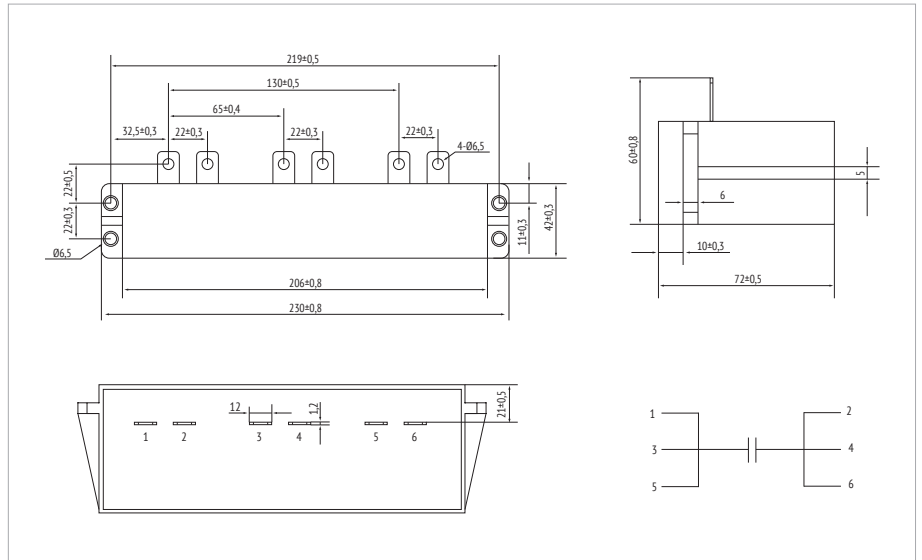

EXAMPLE DRAWING #4

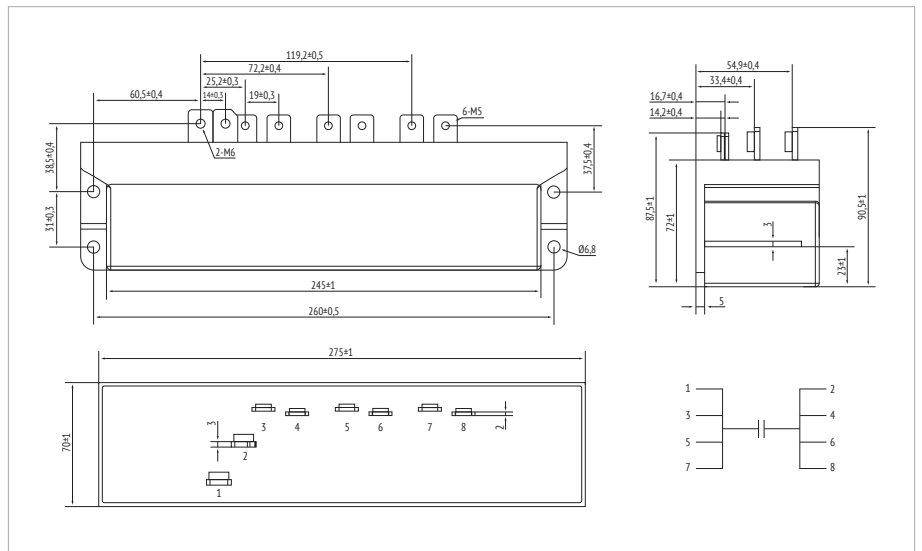

EXAMPLE DRAWING #5

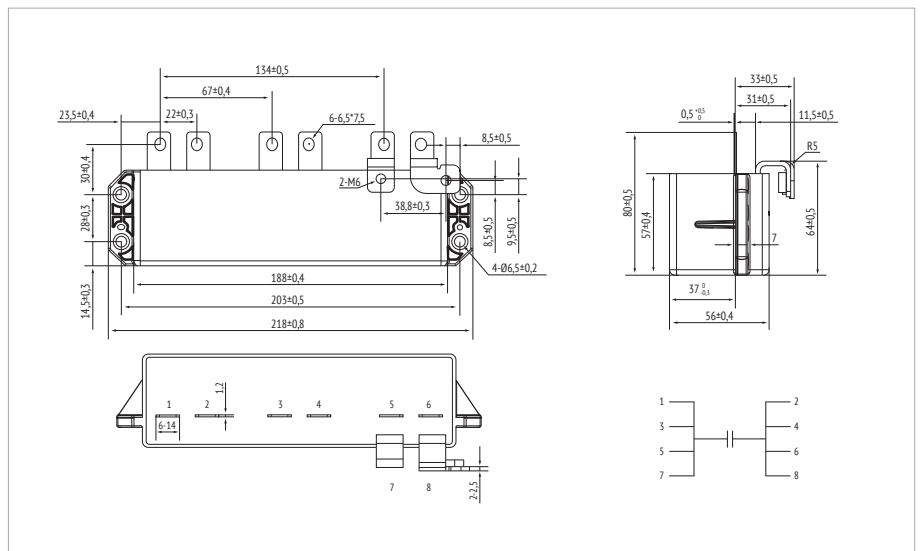

in mm

MODULES



EXAMPLE DRAWING #6 ▶

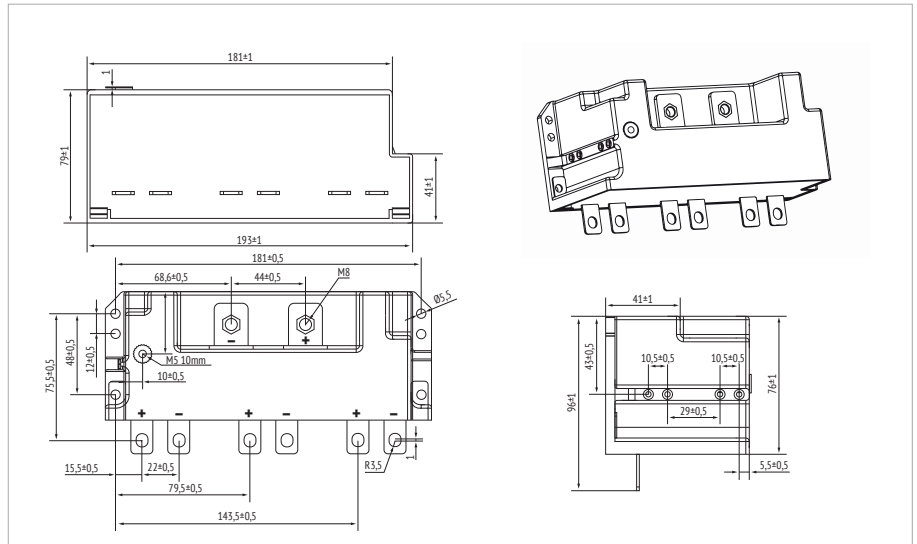

EXAMPLE DRAWING #7 ▶

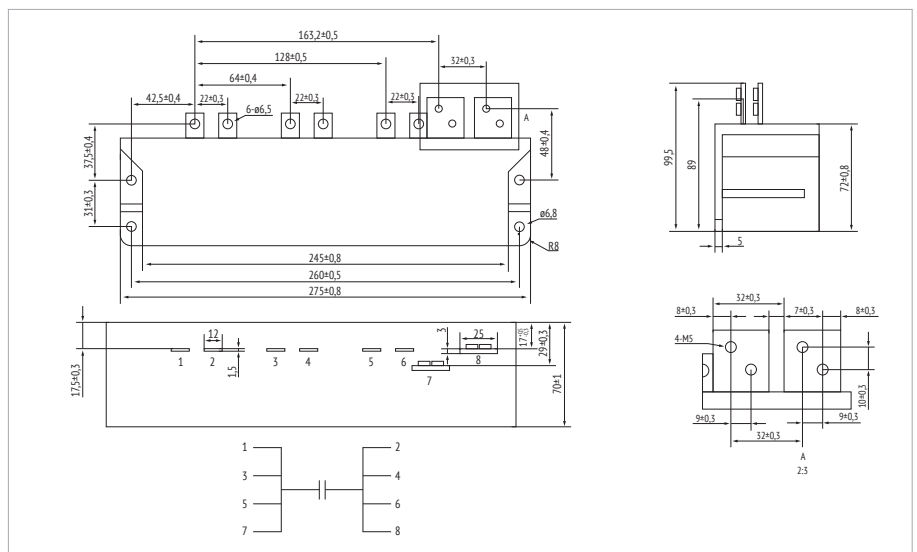

EXAMPLE DRAWING #8 ▶

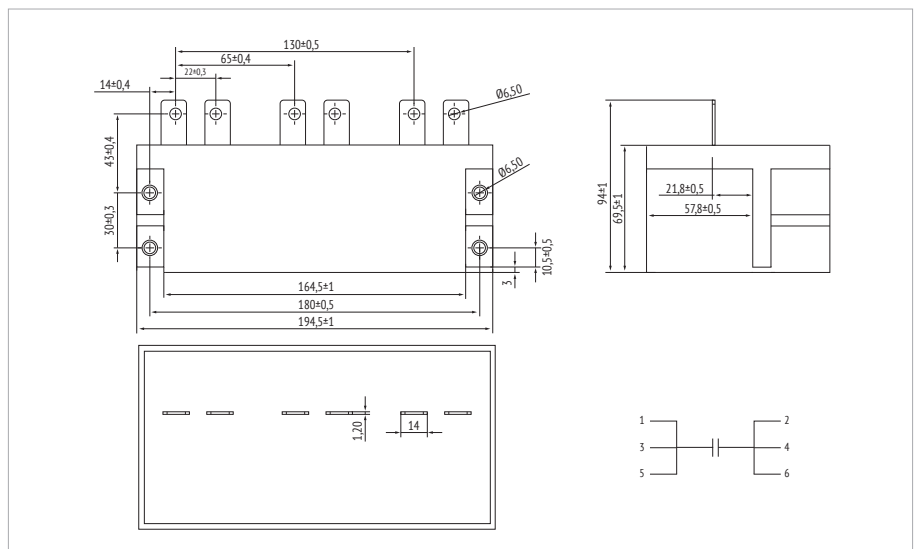

in mm

MODULES



EXAMPLE DRAWING #9

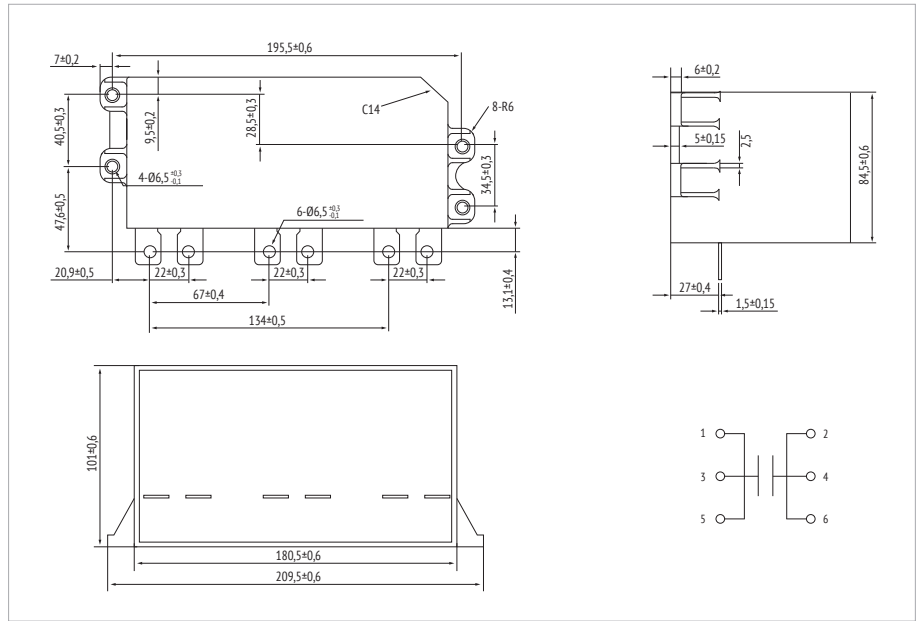

EXAMPLE DRAWING #10

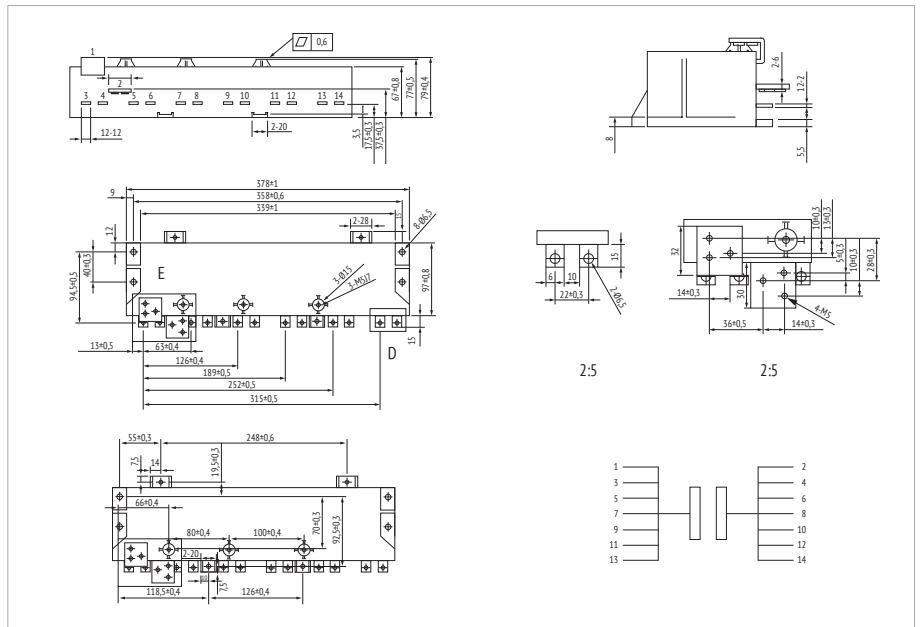

EXAMPLE DRAWING #11

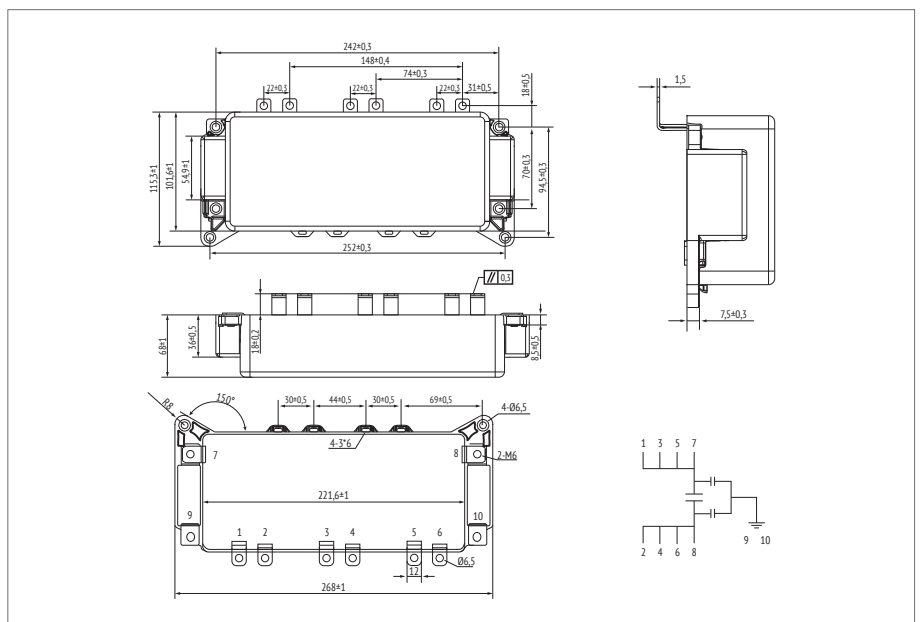

in mm

MODULES



## ORDER CODE

FC	S	2W	DV	507	K	B010	0	2	1	E 3
Capacitor type	Product shape	DC rated voltage code (V)	Series code	Capacitance Code (μF)	Capacitance tolerance	Dimension Code W x H x T (mm)	Hole Shape (mm)	Terminal Pitch (mm)	Mounting Hole	For internal use
Film Cap. = FC	Square box = S	450 <b>2W</b> 500 <b>2H</b> 600 <b>2S</b> 800 <b>2K</b>	CBB 135 = DV	500 <b>507</b> 1000 <b>108</b>	±5% <b>J</b> ±10% <b>K</b>	275 x 72 x 70 <b>B010</b> 376 x 97 x 67 <b>B018</b> other on request	6,5 <b>0</b> 5,5 <b>3</b> M6 <b>1</b> M5 <b>2</b>	19 <b>1</b> 22 <b>2</b>	Without <b>0</b> With <b>1</b> Other <b>Y</b>	

## RATINGS

U <sub>R</sub> ≤85°C (V <sub>DC</sub> )	C <sub>R</sub> (μF)	I <sub>max</sub> 85°C, 10kHz (A)	f <sup>(1)</sup> (A)	ESR <sub>typ</sub> 20°C, 10kHz (mΩ)	L <sub>s</sub> 20°C (nH)	W (mm)	H (mm)	T (mm)	ORDER CODE
<b>450 2W</b>	400	100	2000	0,5	15	249	47	50	FCS2WDV407KB156021YE3
	1000	150	4000	0,6	30	268	53	101,6	FCS2WDV108KB025011E3
<b>500 2H</b>	500	90	2500	0,8	15	206	42	72	FCS2HDV507KB101021E3
	500	130	2500	0,45	18	197	78,5	40	FCS2HDV507KB191021YE3
	700	130	7000	0,5	15	214	42	82	FCS2HDV707KB194811E3
	850	180	5500	0,5	15	275	72	70	FCS2HDV857KB010811E3
<b>600   2S</b>	450	125	3300	0,42	18	188	57	56	FCS2SDV457KB109021E3
<b>800 2K</b>	300	125	3000	0,5	18	188	57	56	FCS2KDV307KB109021E3
	400	110	2000	0,6	20	193	76	79	FCS2KDV407KB059121E3
	420	100	4000	0,65	15	210	81	72	FCS2KDV427KB009021E3
	500	150	4000	0,6	15	275	72	70	FCS2KDV507KB010021E3
	500	160	6000	0,6	30	194,5	69,5	100	FCS2KDV507KB051021E3
	560	200	8000	0,4	24	209,5	84,5	101	FCS2KDV567KB037021E3
	850	200	8000	0,4	20	376	97	67	FCS2KDV857KB018021E3
	850	200	8000	0,4	15	361	70	65	FCS2KDV857KB166021E3
	900	180	4500	0,5	20	291	219	40	FCS2KDV907KB114231E3
	1000	160	4000	0,8	30	268	68	101,6	FCS2KDV108KB015021E3

(1) Maximum permissible peak current



## CAPACITOR COMPETENCE

*since 1958*

### JIANGHAI EUROPE

Electronic Components GmbH



ENGINEERED SOLUTIONS

#### **Jianghai Europe Electronic Components GmbH**

Uerdinger Str. 95 · 47799 Krefeld/Germany

Tel.: +49 (0) 2151-652088-0 · Fax: -88

info@jianghai-europe.com

www.jianghai-europe.com

#### **Nantong Jianghai Capacitor Co., Ltd.**

No. 79 South Tong Yang Road

226361 Nantong, Jiangsu/China

Tel.: +86-513-8672-6080 · Fax: -3859

jh@jianghai.com

www.jianghai.com

#### **Jianghai America Inc.**

3104 Sunrise Ridge LN

Hacienda Heights, CA 91745/USA

Tel.: +1-626-274-1692 · Fax: +1-626-336-6960

wangjuan@jianghai-america.com

www.jianghai-america.com